

[54] **COMBINED TELEPHONE BOOTH AND ADVERTISING DISPLAY UNIT**

[76] Inventors: **J. Rembrandt George**, 91 Pine St., Garden City, N.Y. 11530; **William L. Schuyler**, Rte. 1, Box 208, Denton, Md. 21629

[**] Term: **14 Years**

[21] Appl. No.: **65,140**

[22] Filed: **Aug. 9, 1979**

[51] Int. Cl. **D25—03; D20—02; D26—03**

[52] U.S. Cl. **D6/157; D6/25; D6/29; D6/186; D20/19; D20/41; D25/16; D26/52; D26/67**

[58] Field of Search **D6/20, 25, 27, 28, 114, D6/132, 133, 157, 186; D25/16; 40/541, 584; 179/183; 52/27, 28, 36, 38, 40; D20/19, 41; D26/51, 52, 67-68, 72, 86, 88-89, 120, 123, 124; 362/362, 812**

[56] **References Cited**

U.S. PATENT DOCUMENTS

D. 84,324	6/1931	Bowen	D26/67
D. 196,497	10/1963	Hannula et al.	D6/29
D. 213,521	3/1969	Vesely et al.	D26/67
D. 217,637	5/1970	Moore	D26/67
2,270,377	1/1942	McLauchin	.	
2,559,163	7/1951	MacDonald	.	
2,825,799	3/1958	Julien	.	
2,982,593	5/1961	Chambers	52/27
3,224,129	12/1965	Green	.	
3,242,329	3/1966	Abrams	.	
3,274,548	9/1966	Brimsek	.	
3,290,813	12/1966	Rose, Sr.	.	
3,318,031	5/1967	Whaley et al.	.	
3,319,060	5/1967	Bartley	362/812
3,845,590	11/1974	Ertl	179/183
4,052,806	10/1977	George	.	

FOREIGN PATENT DOCUMENTS

1145201 3/1969 United Kingdom .

OTHER PUBLICATIONS

Sweet's Arch. Cat. File 1975, Sec. 10.9/Aco, p. 1, booth ADCO 120.

Primary Examiner—B. J. Bullock

Attorney, Agent, or Firm—Pennie & Edmonds

[57] **CLAIM**

The ornamental design for a combined telephone booth and advertising display unit, substantially as shown and described.

DESCRIPTION

FIG. 1 is a reduced front perspective view of a combined telephone booth and advertising display unit showing our new design, the rear and side opposite that shown are identical;
 FIG. 2 is an end elevational view of the advertising display unit shown separately for clarity of illustration;
 FIG. 3 is a bottom plan view of FIG. 2;
 FIG. 4 is a side elevational view of FIG. 2;
 FIG. 5 is a top plan view of FIG. 2;
 FIG. 6 is a reduced front perspective view of a second embodiment of the design of FIG. 1, the rear and side opposite that shown are identical;
 FIG. 7 is an end elevational view of the advertising display unit shown separately for ease of illustration;
 FIG. 8 is a bottom plan view of FIG. 7;
 FIG. 9 is a side elevational view of FIG. 7;
 FIG. 10 is a top plan view of FIG. 7;
 FIG. 11 is a reduced front perspective view of a third embodiment of the design of FIG. 1, the rear and side opposite that shown are identical;
 FIG. 12 is an end elevational view of the advertising display unit shown separately for clarity of illustration;
 FIG. 13 is a bottom plan view of FIG. 12;
 FIG. 14 is a side elevational view of FIG. 12;
 FIG. 15 is a top plan view of FIG. 12.

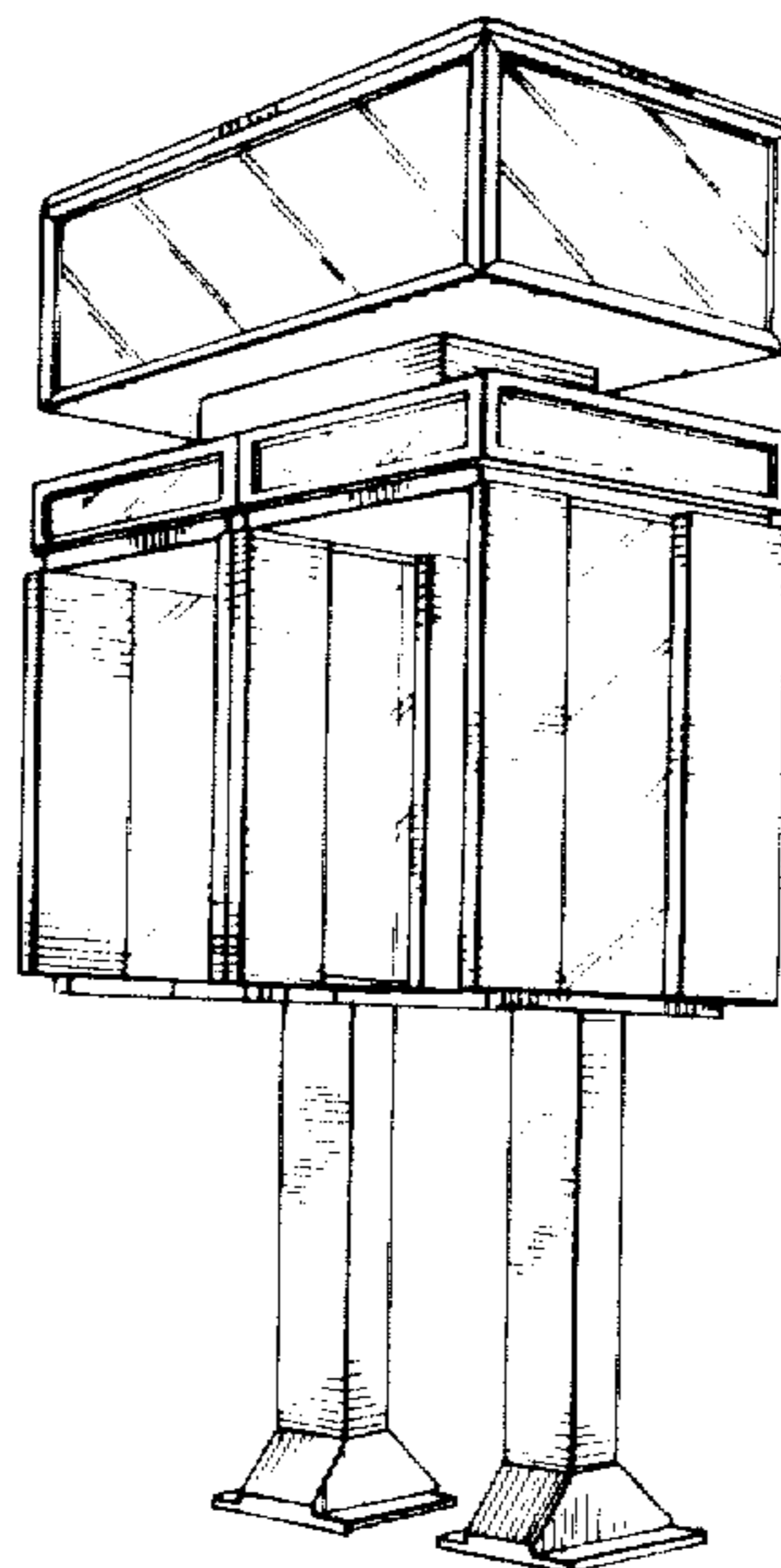

FIG. 1

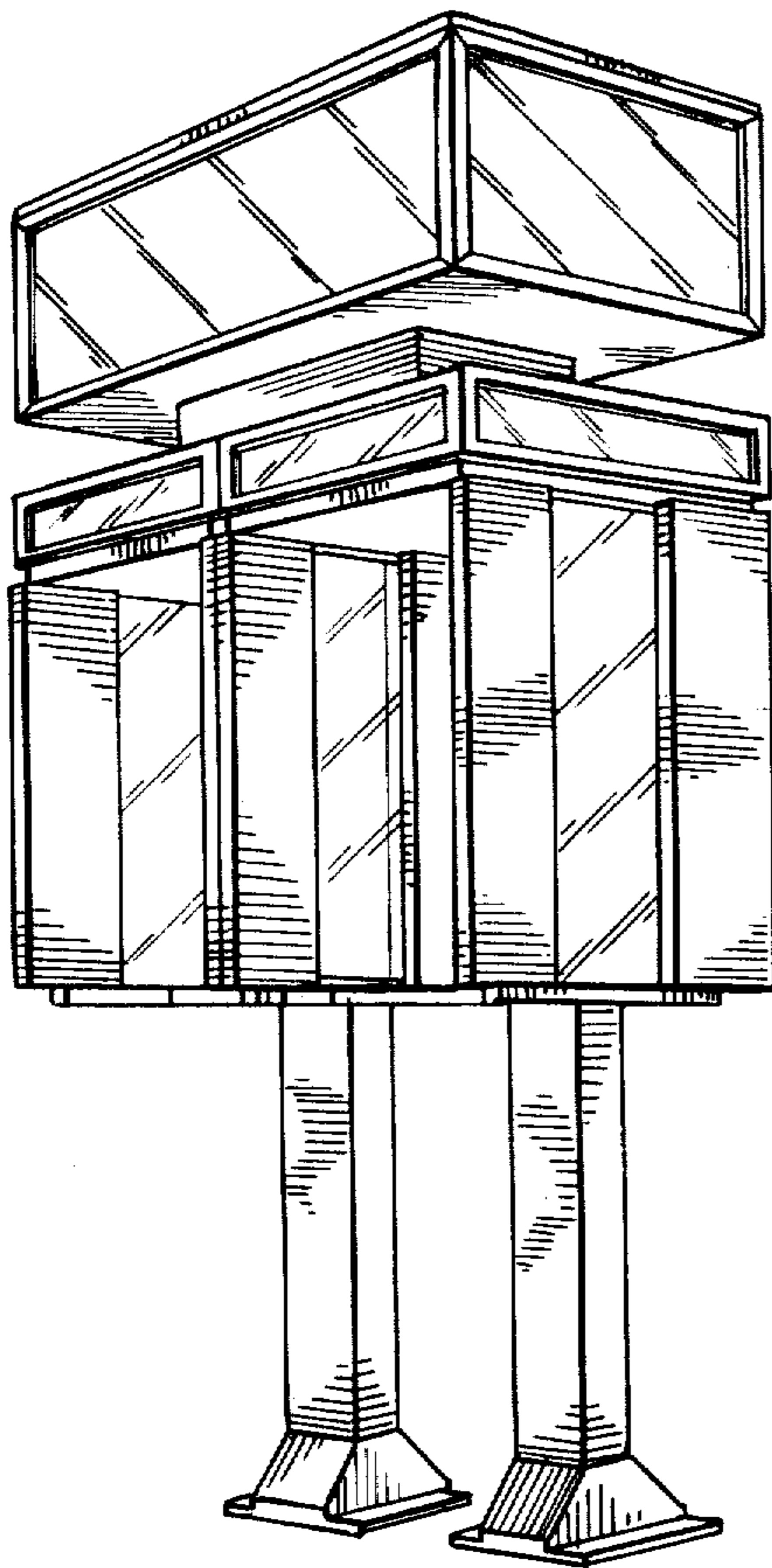

FIG. 2

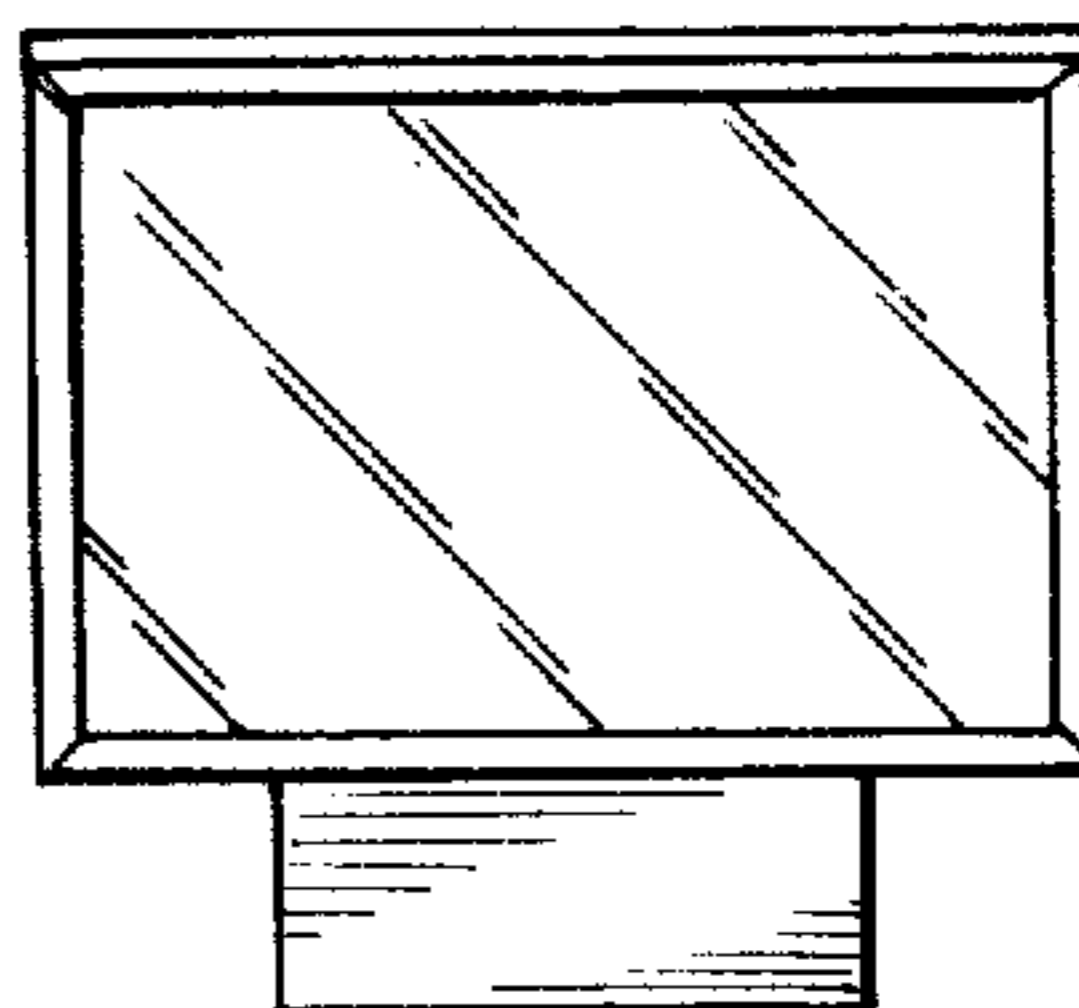

FIG. 3

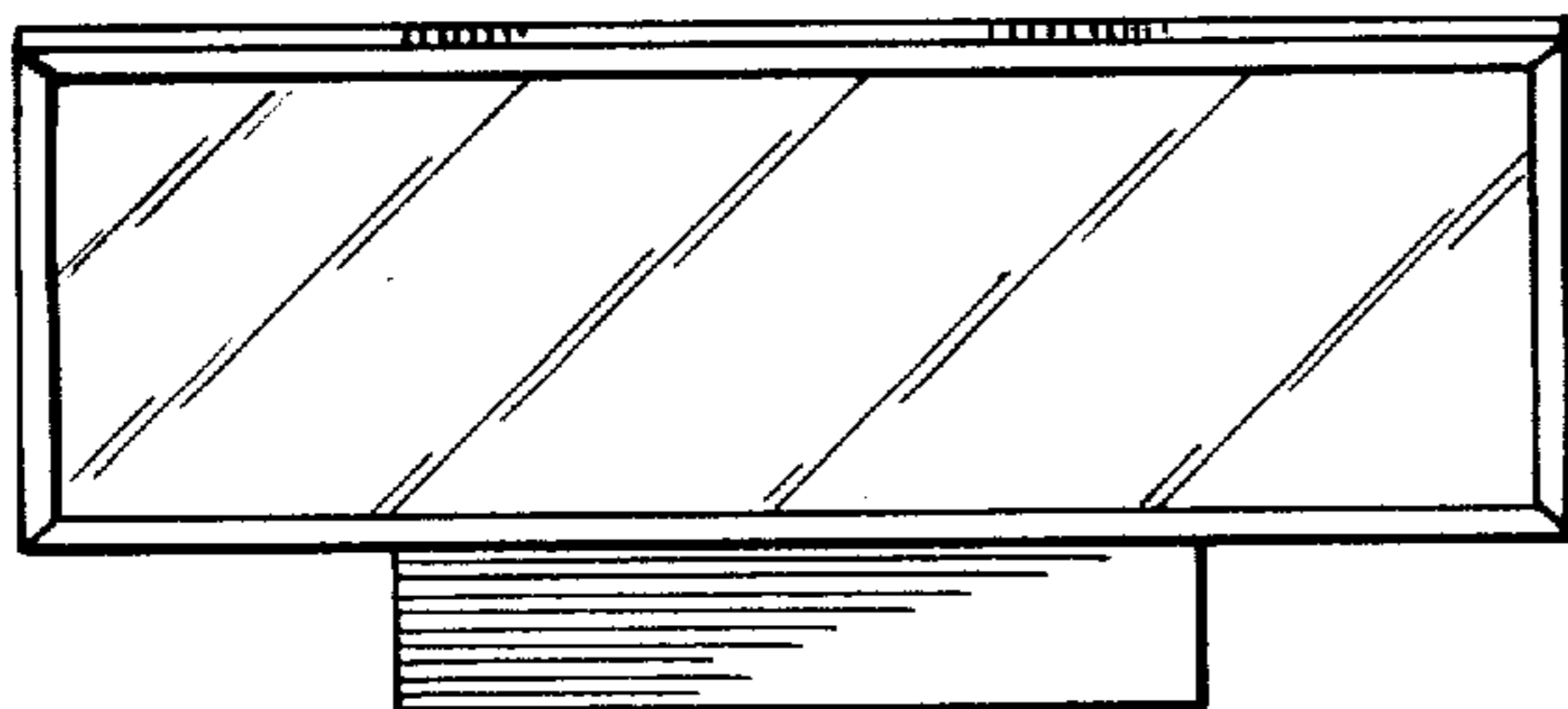
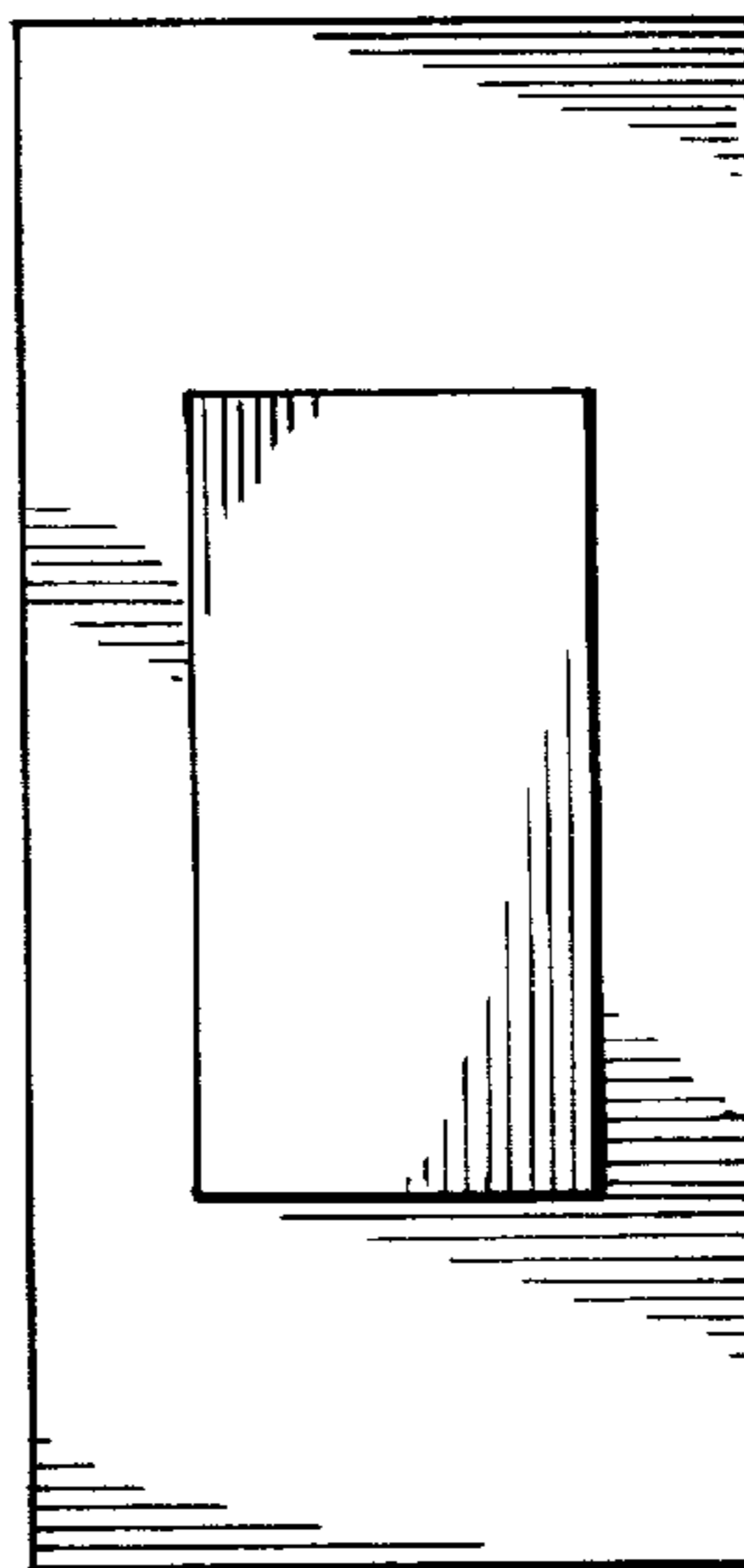

FIG. 4

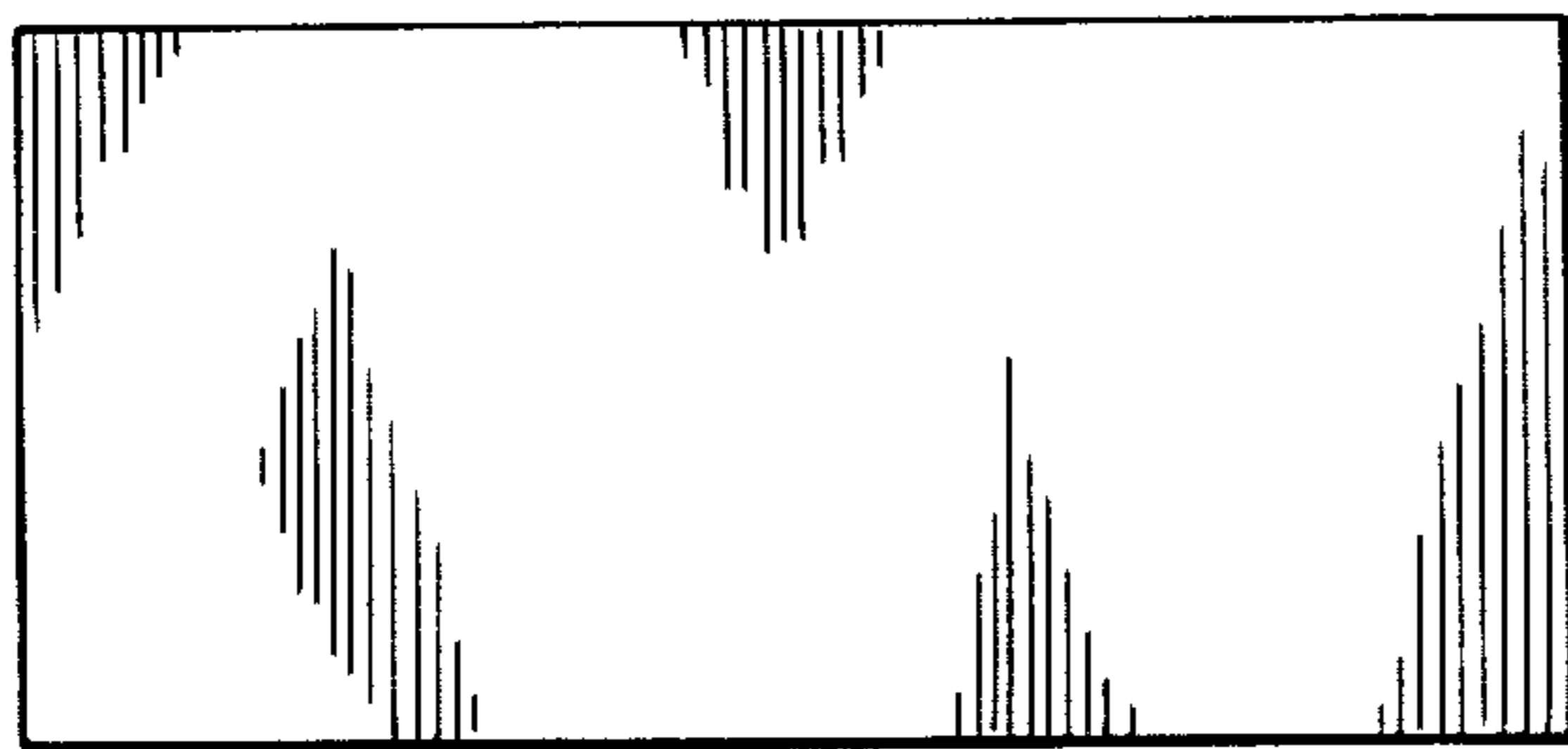

FIG. 5

FIG. 6

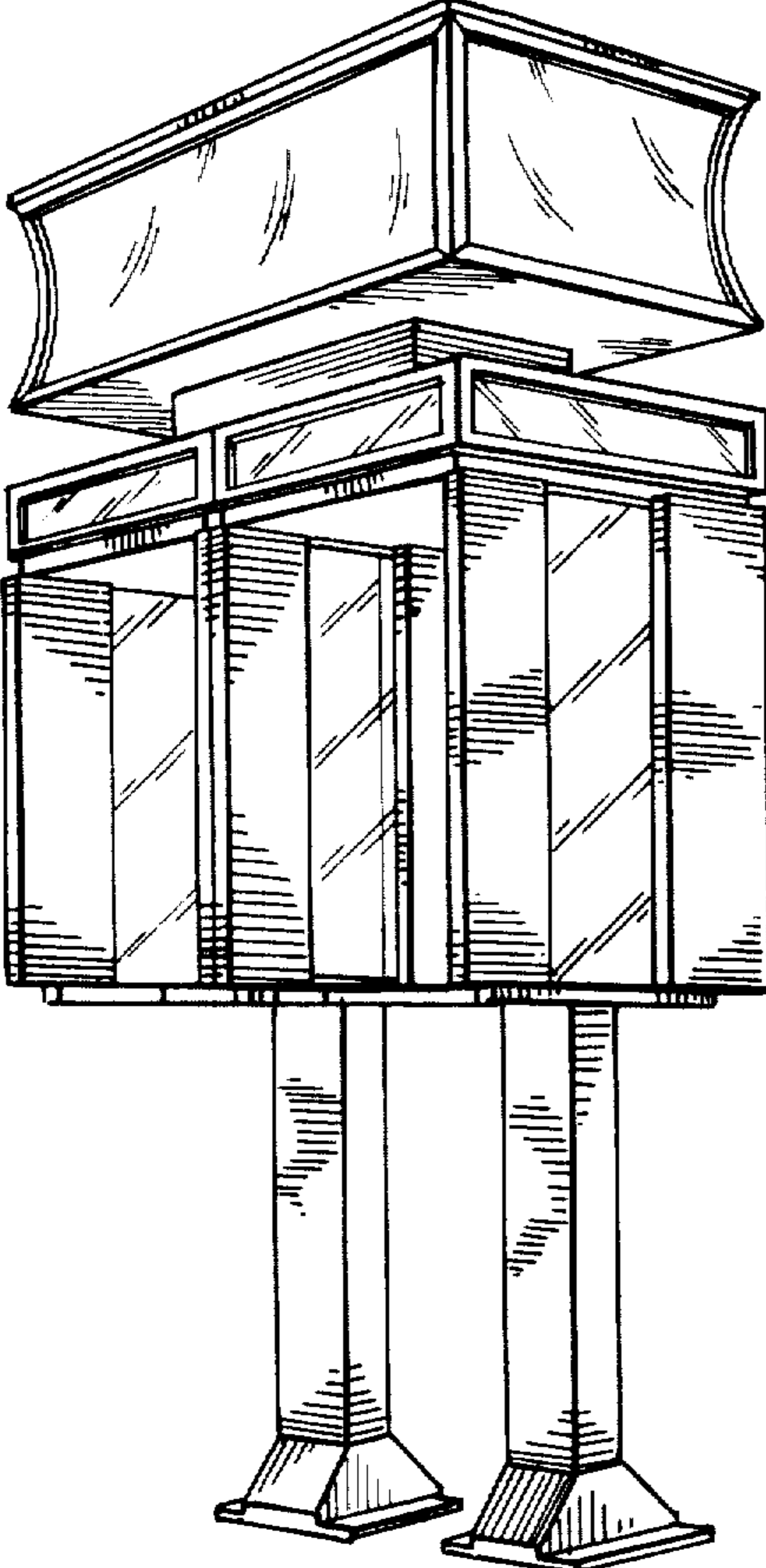

FIG. 7

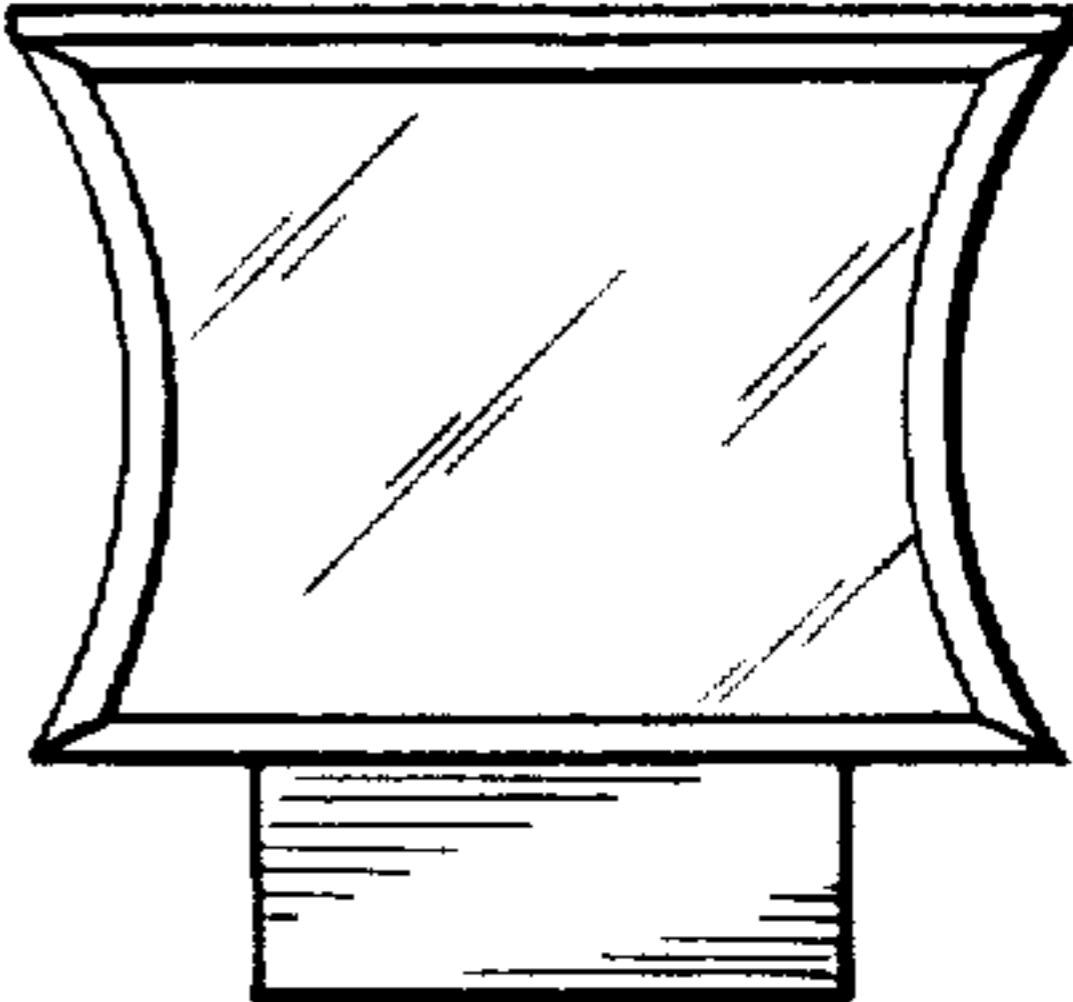

FIG. 8

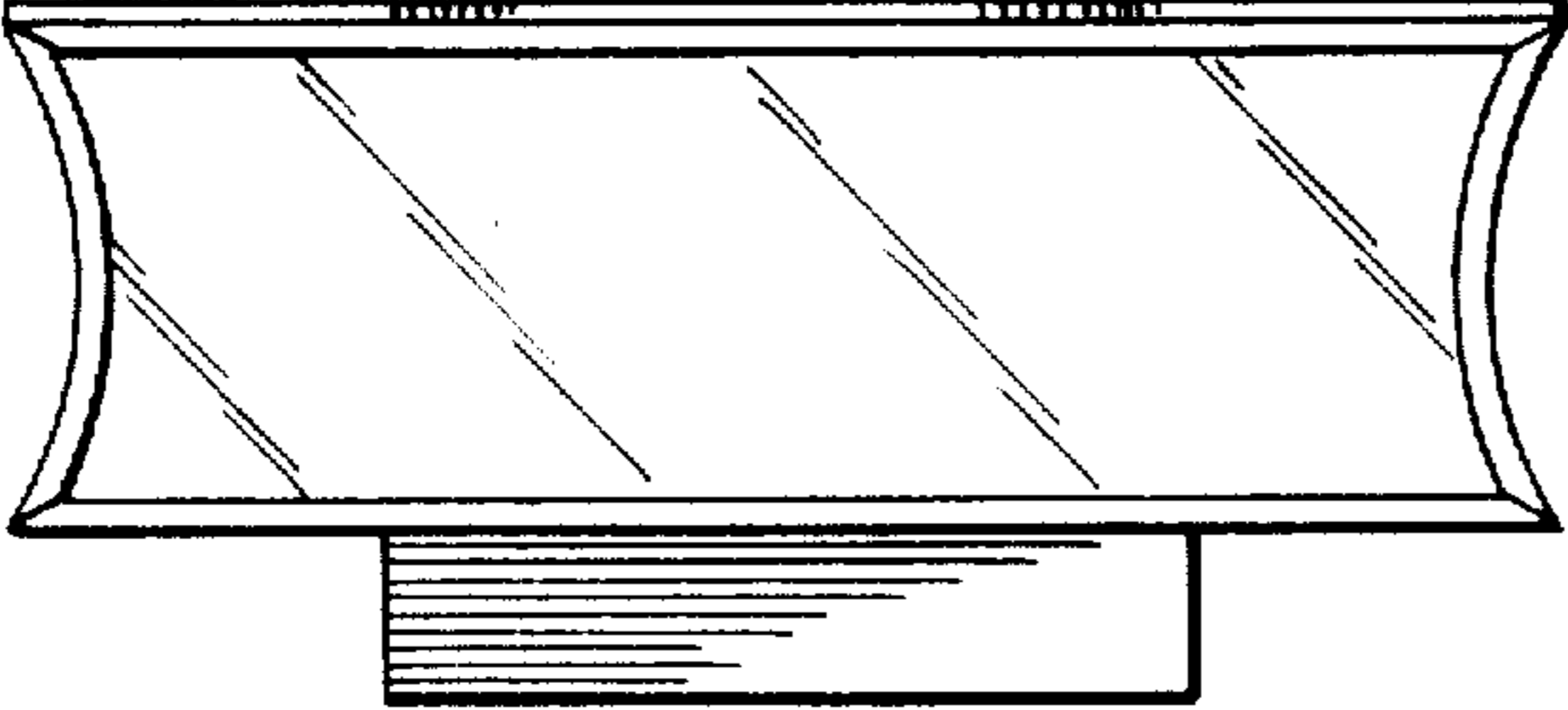
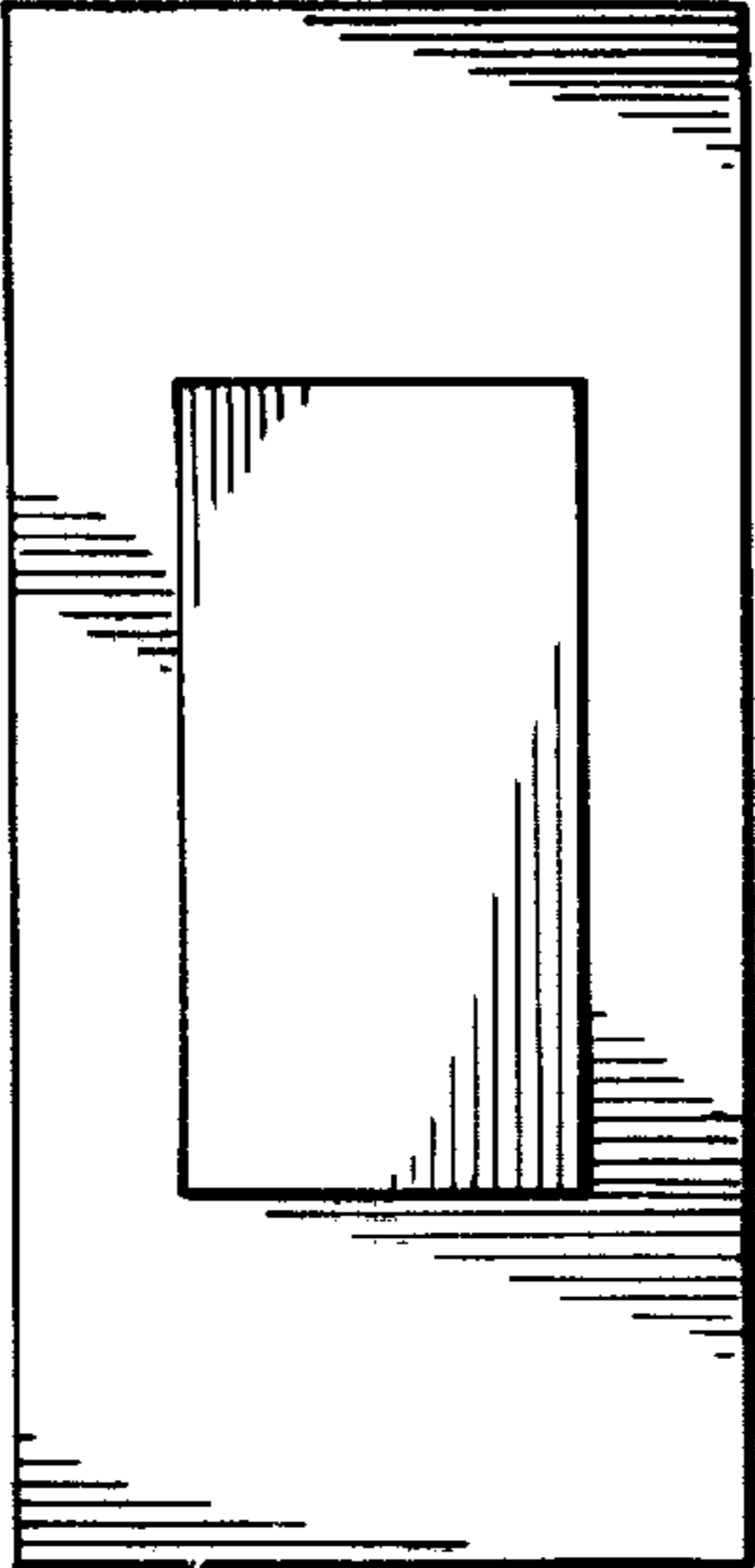

FIG. 9

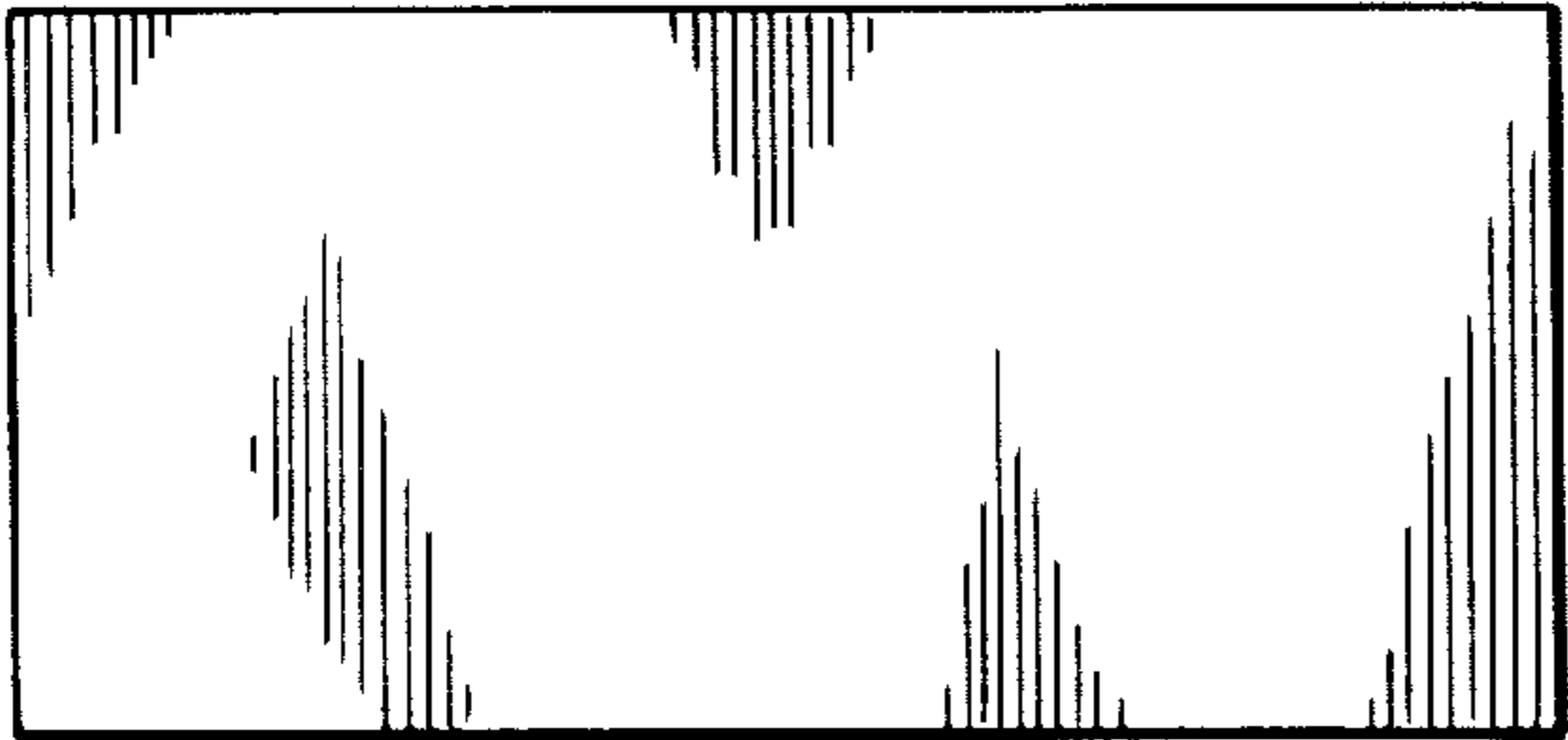

FIG. 10

FIG. 11

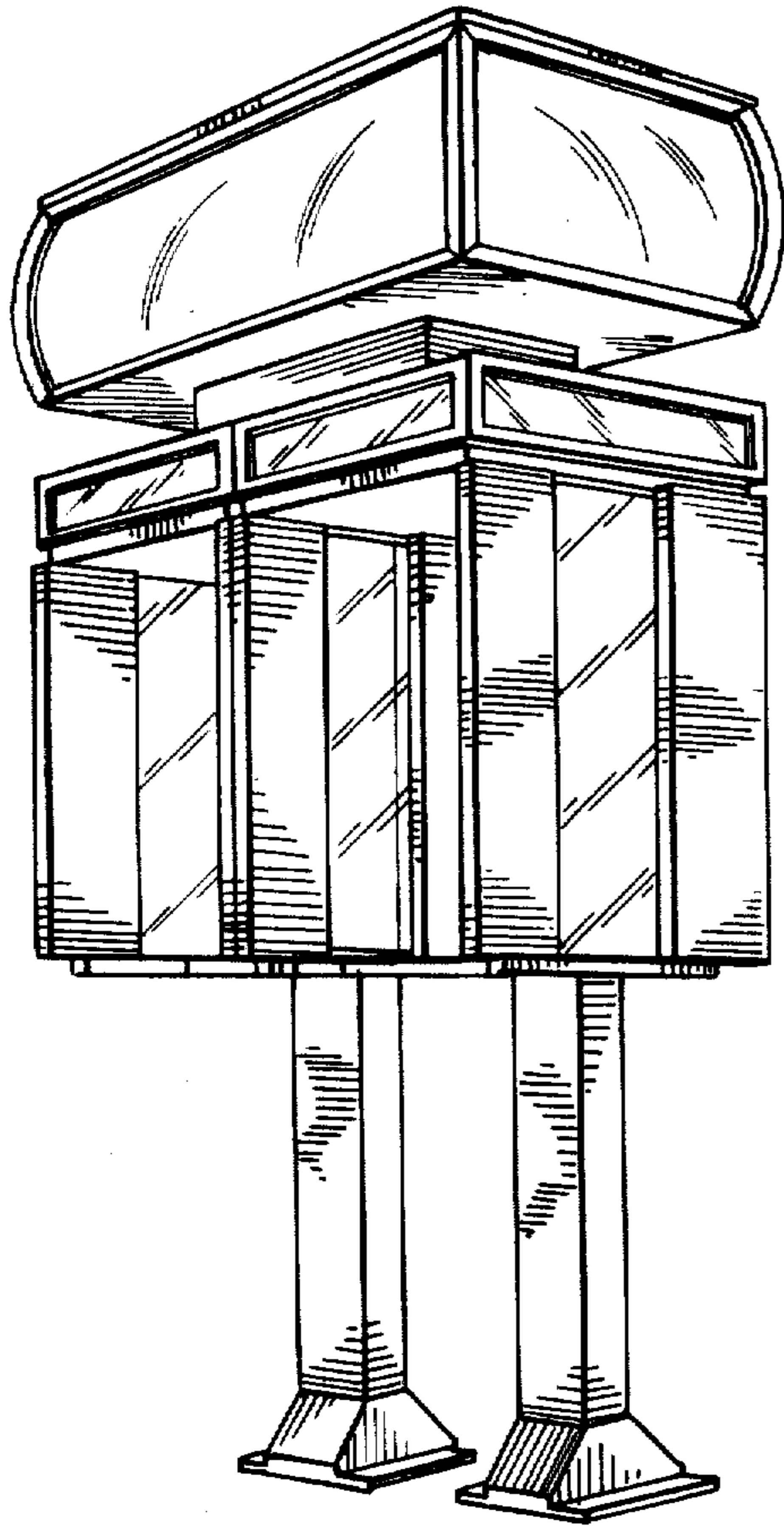

FIG. 12

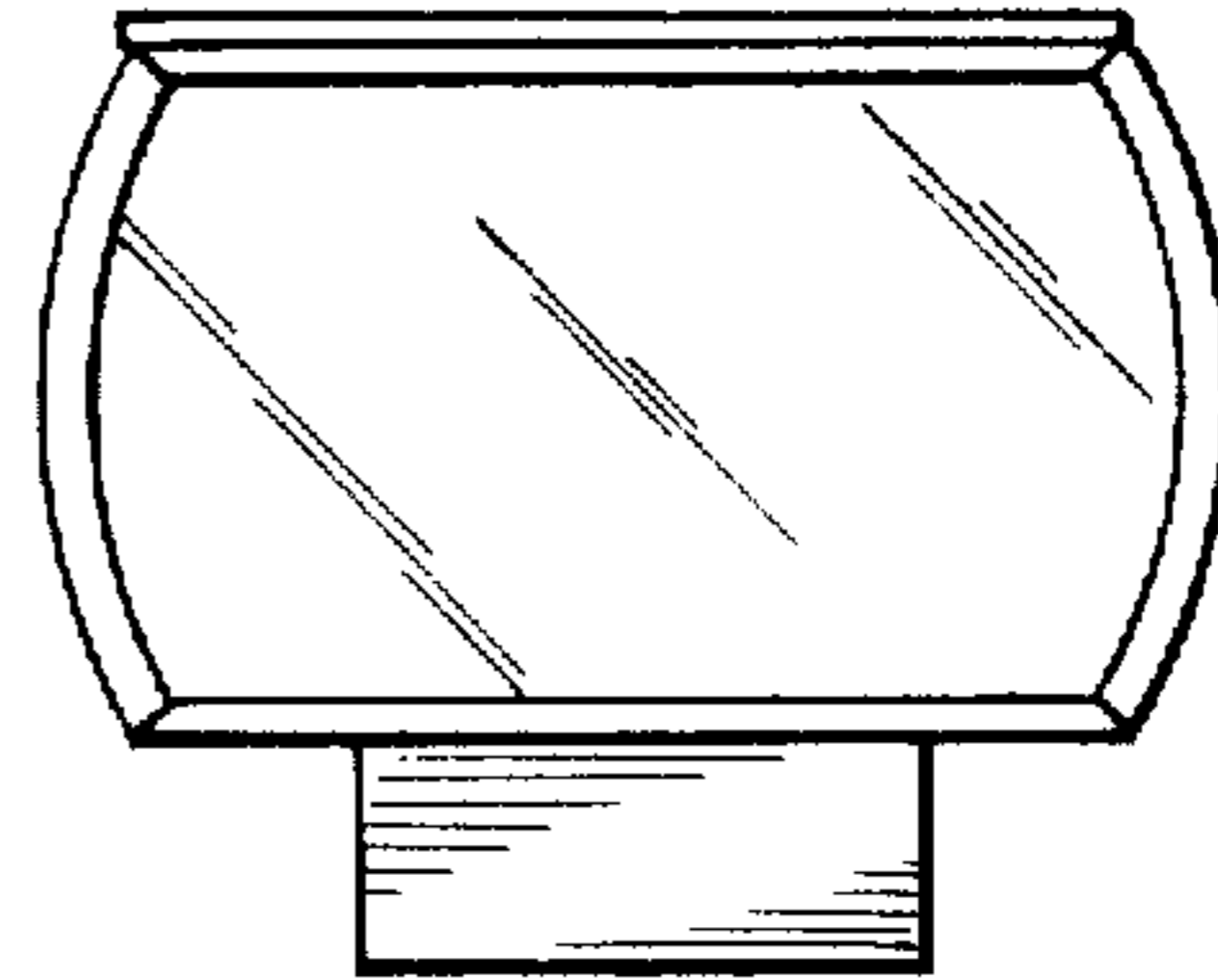

FIG. 13

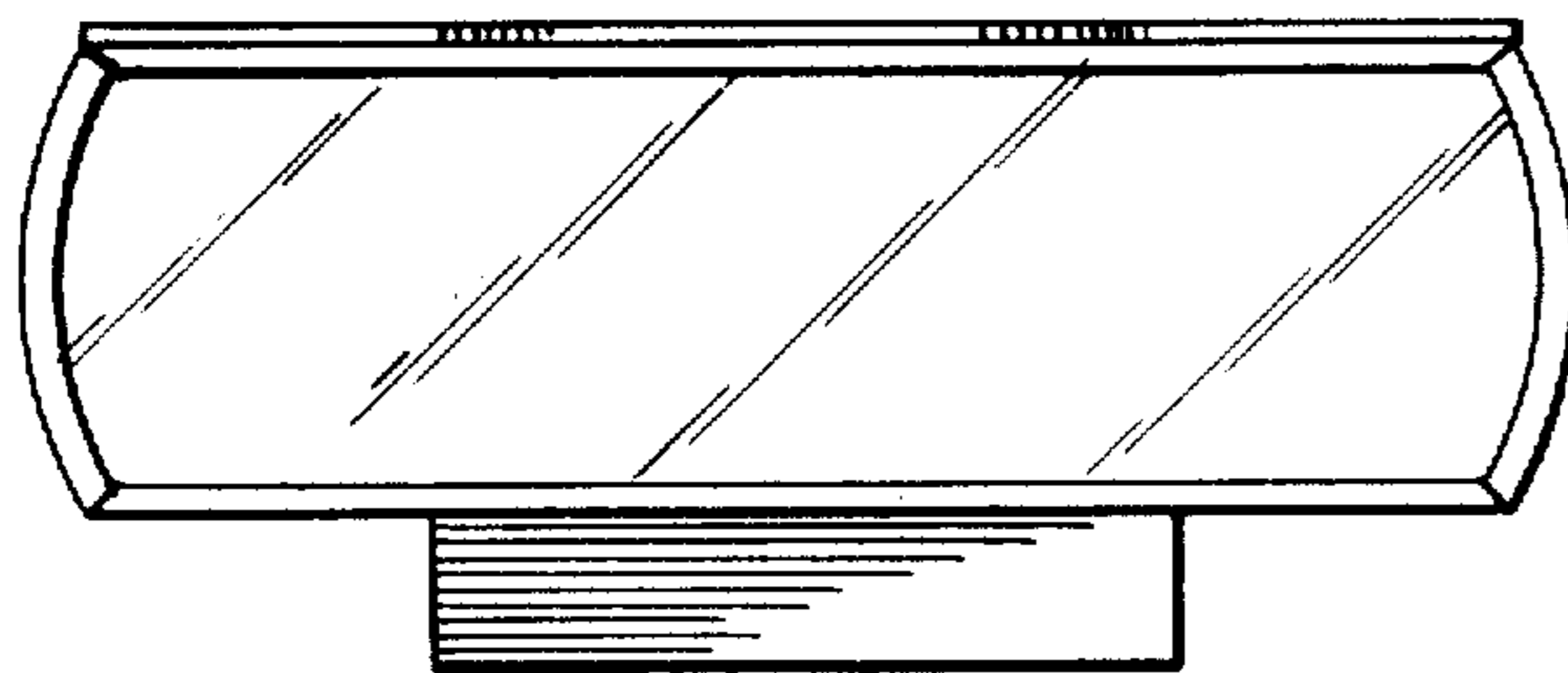
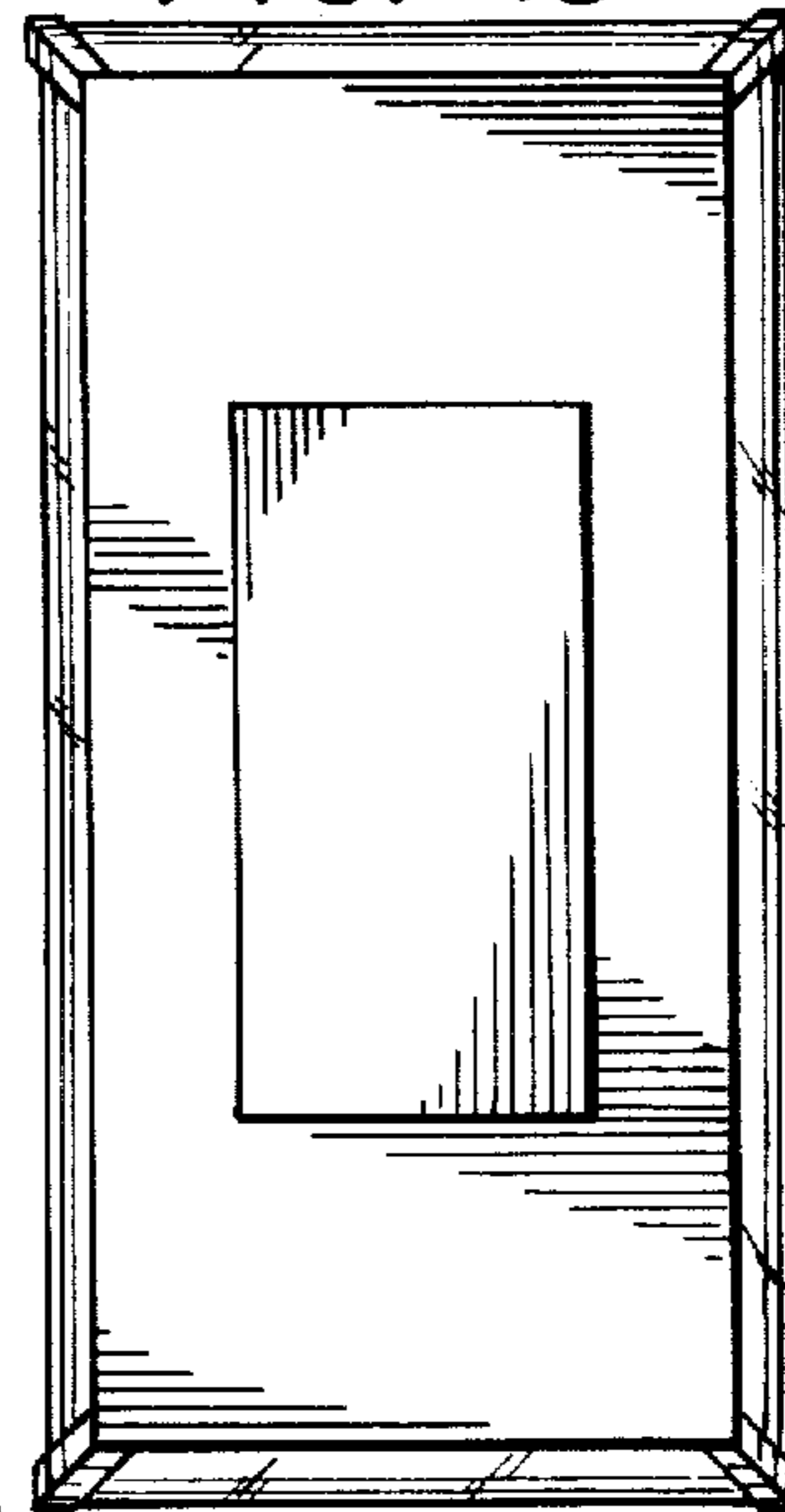

FIG. 14

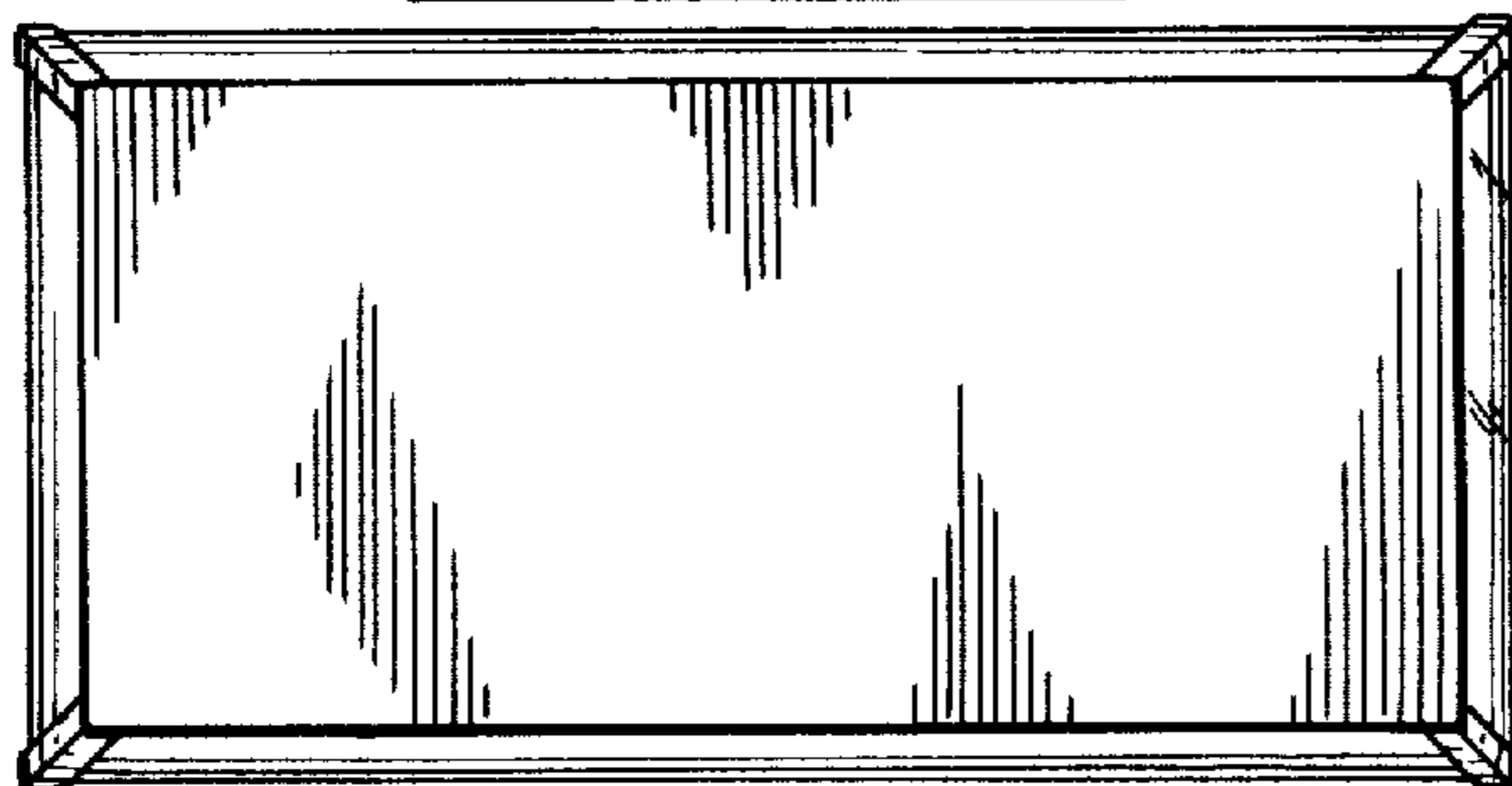

FIG. 15