

[54] PAIR OF SPECTACLES

[75] Inventor: David W. Johnsen, Woodstock, Conn.

[73] Assignee: American Optical Corporation, Southbridge, Mass.

[**] Term: 14 Years

[21] Appl. No.: 42,698

[22] Filed: May 25, 1979

[51] Int. Cl. D16-06

[52] U.S. Cl. D16/117

[58] Field of Search D16/65, 69, 70, 76, D16/77, 80, 81; 351/41, 44, 45, 46, 47, 49, 51, 52, 54, 55, 57, 58, 60, 61, 62, 63, 66, 67, 68, 69, 71, 73-122

[56] References Cited

U.S. PATENT DOCUMENTS

- D. 108,556 2/1938 Splaine D16/78
- D. 242,283 11/1976 Canavan D16/65

OTHER PUBLICATIONS

- Optical Journal & Review of Optometry, 7-1976, p. 15, Frames "New Kingston".
- Optician, 11-22-1974, p. 11, Frames "Mercure".

Optometric Weekly, 8-4-1977, p. 1, frames (right hand side).

Optometric Weekly, 8-11-1977, p. 37, Belle 1 Frames.

Primary Examiner—Susan J. Lucas

Attorney, Agent, or Firm—Alan H. Spencer

[57] CLAIM

The ornamental design for a pair of spectacles, as shown and described.

DESCRIPTION

FIG. 1 is a front elevational view of a pair of spectacles embodying my new design;

FIG. 2 is an elevational view of one side of the pair of spectacles, the opposite side thereof being of substantially the same appearance;

FIG. 3 is a top plan view of the spectacles with a temple broken away for convenience of illustration;

FIG. 4 is a rear elevational view with the temples removed for clarity of illustration;

FIG. 5 is a front elevational view of a second embodiment of my new design;

FIG. 6 is an elevational view of one side thereof, the opposite side being of substantially the same appearance;

FIG. 7 is a top plan view thereof with a temple broken away for convenience of illustration; and

FIG. 8 is a rear elevational view thereof with the temples removed for clarity of illustration.

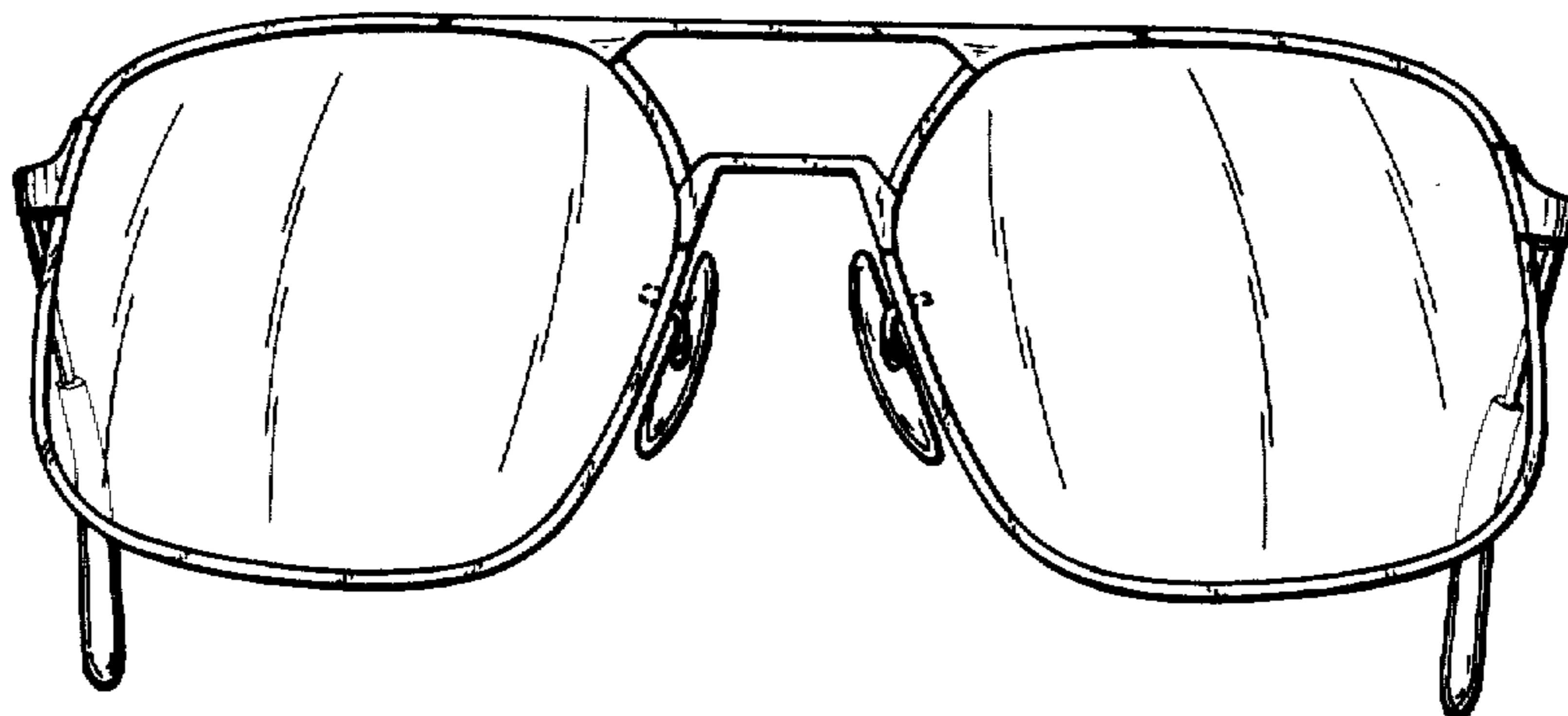

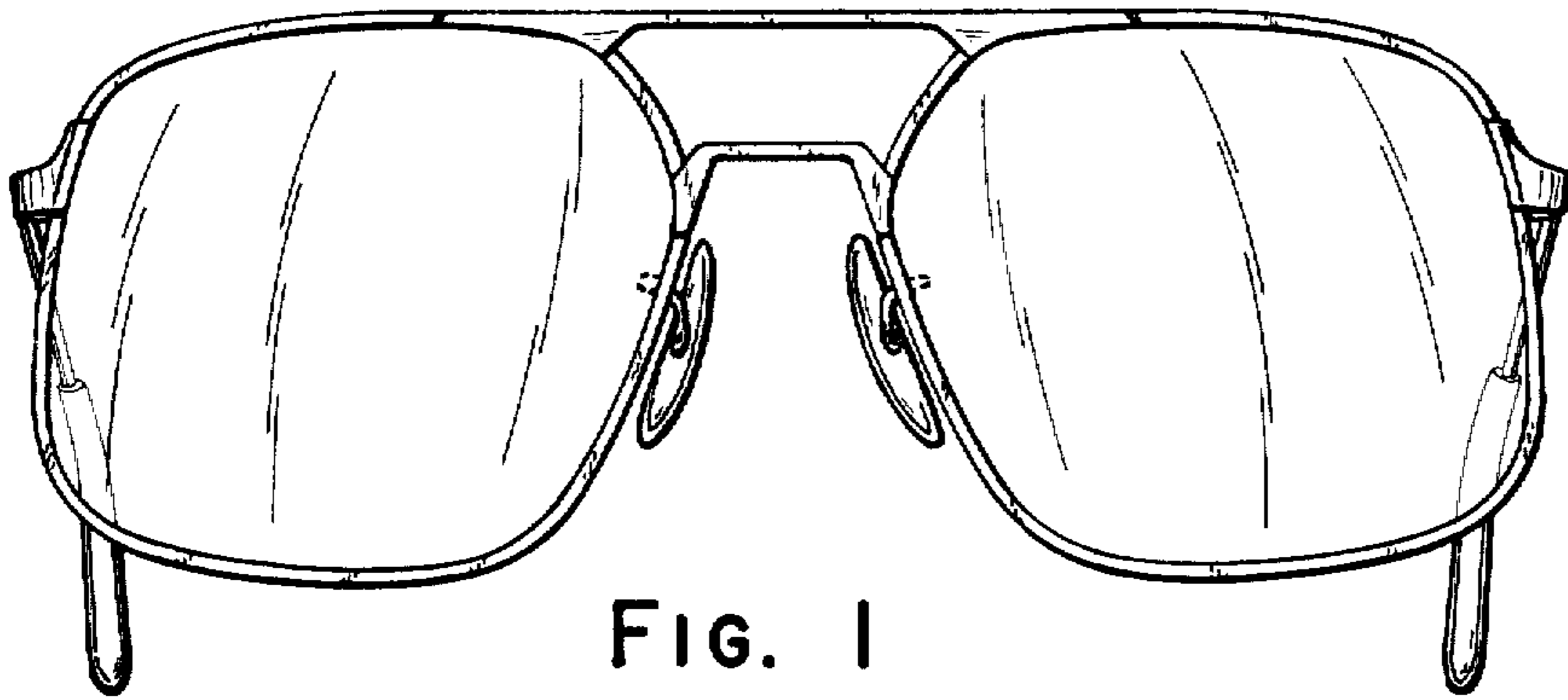

FIG. 1

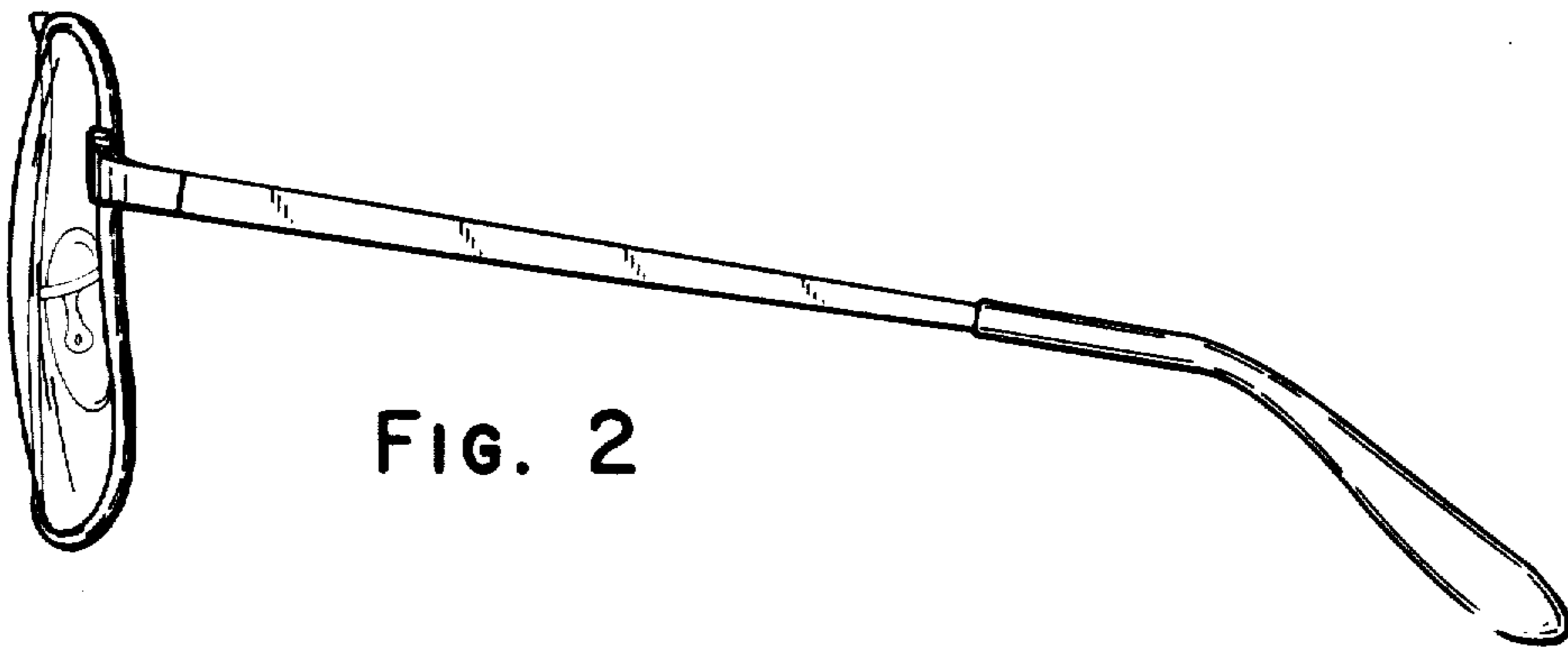

FIG. 2

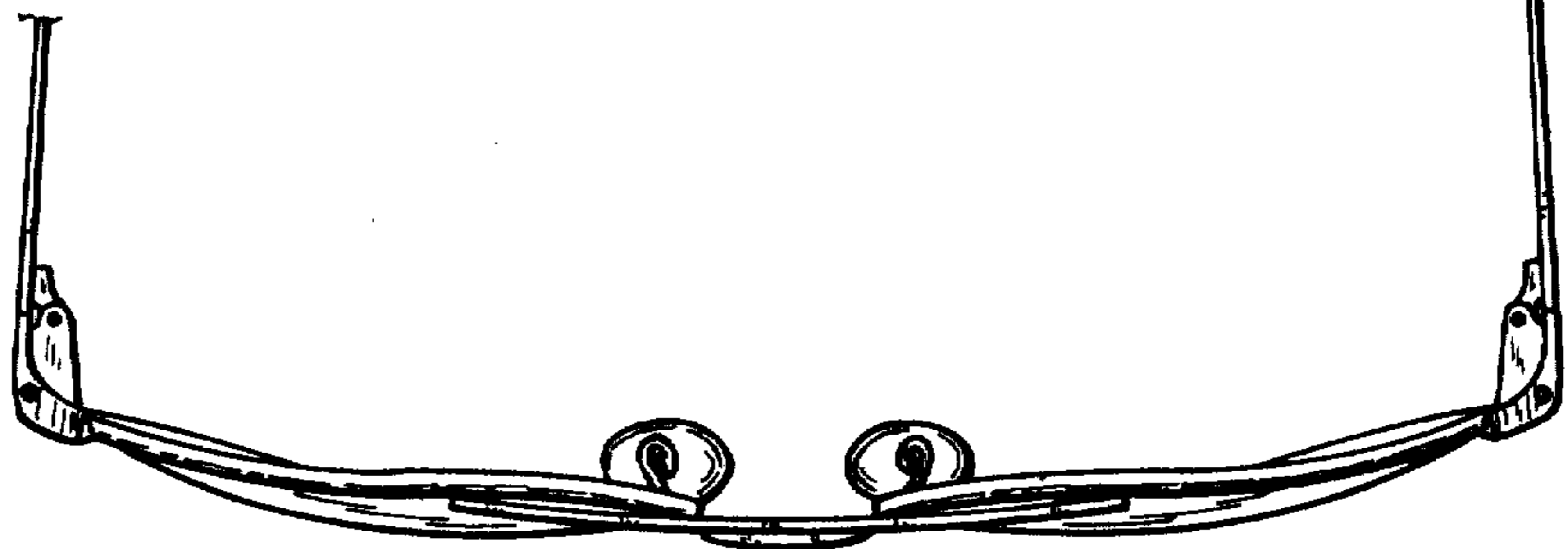

FIG. 3

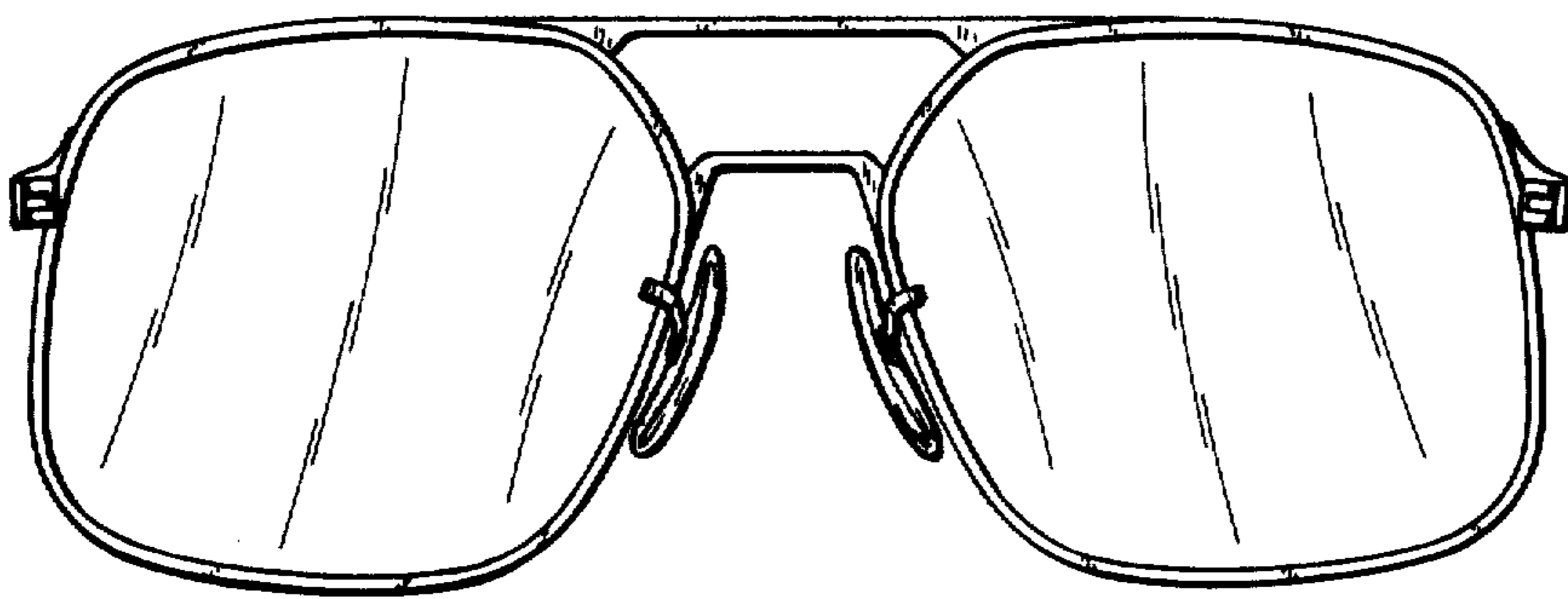

FIG. 4

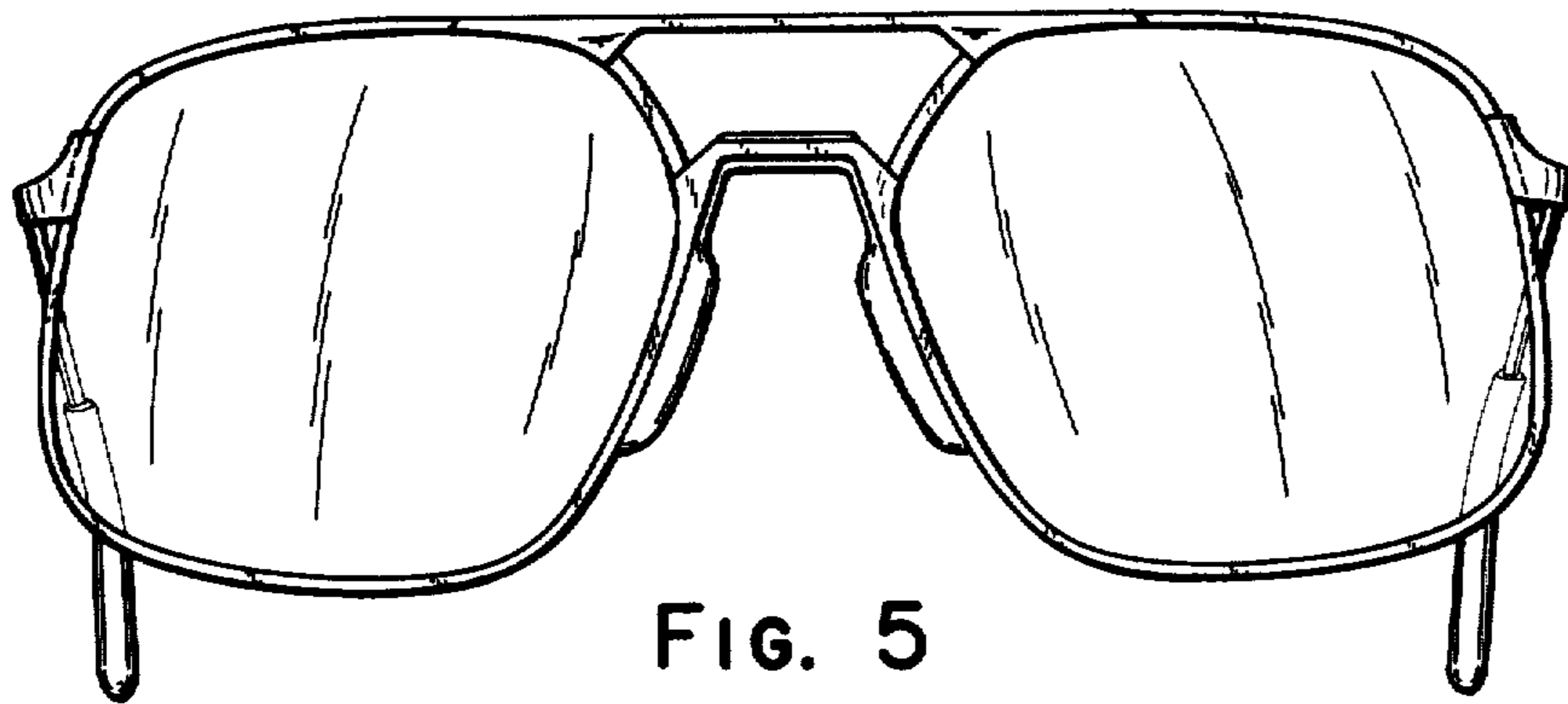

FIG. 5

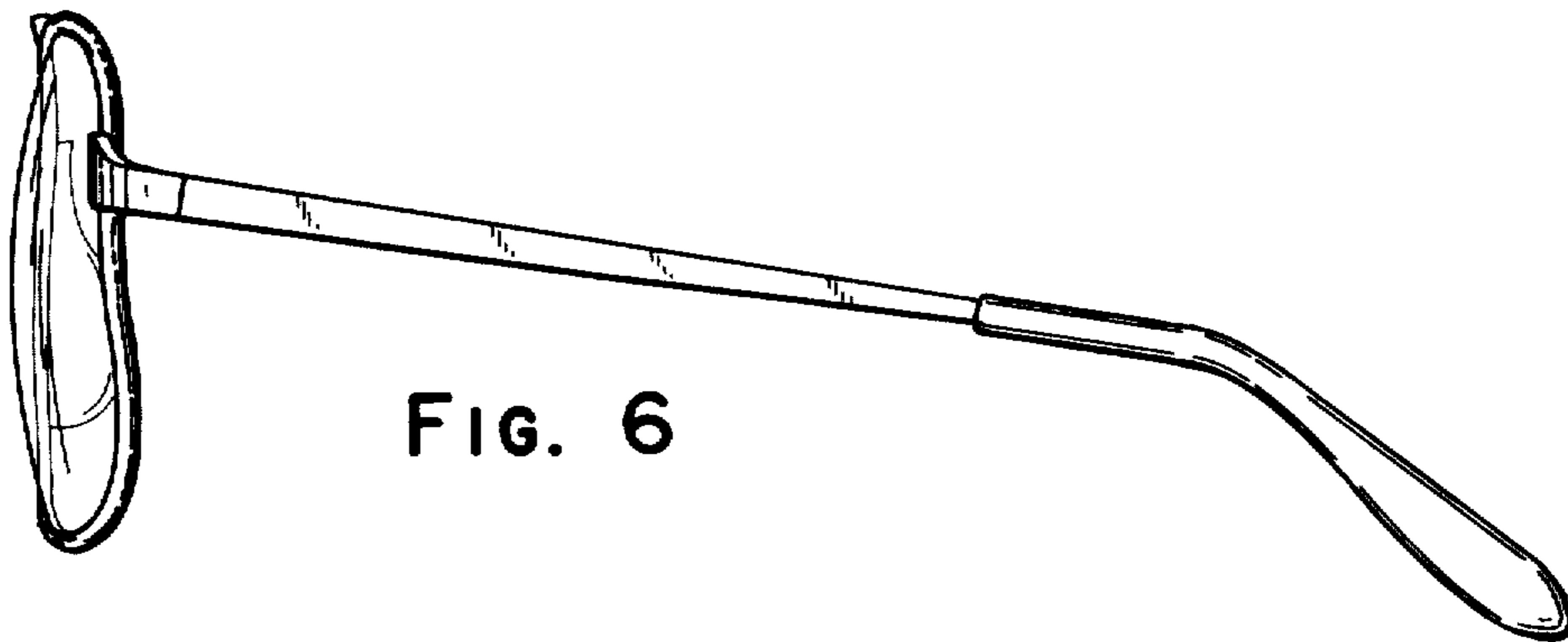

FIG. 6

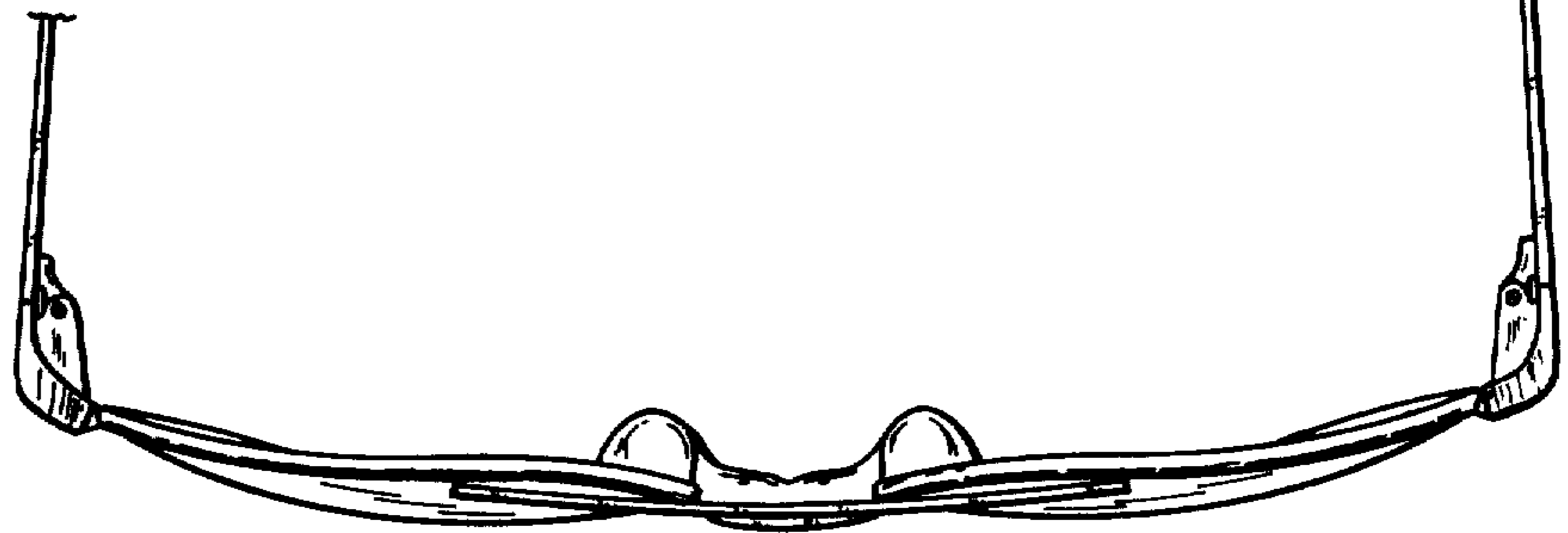

FIG. 7

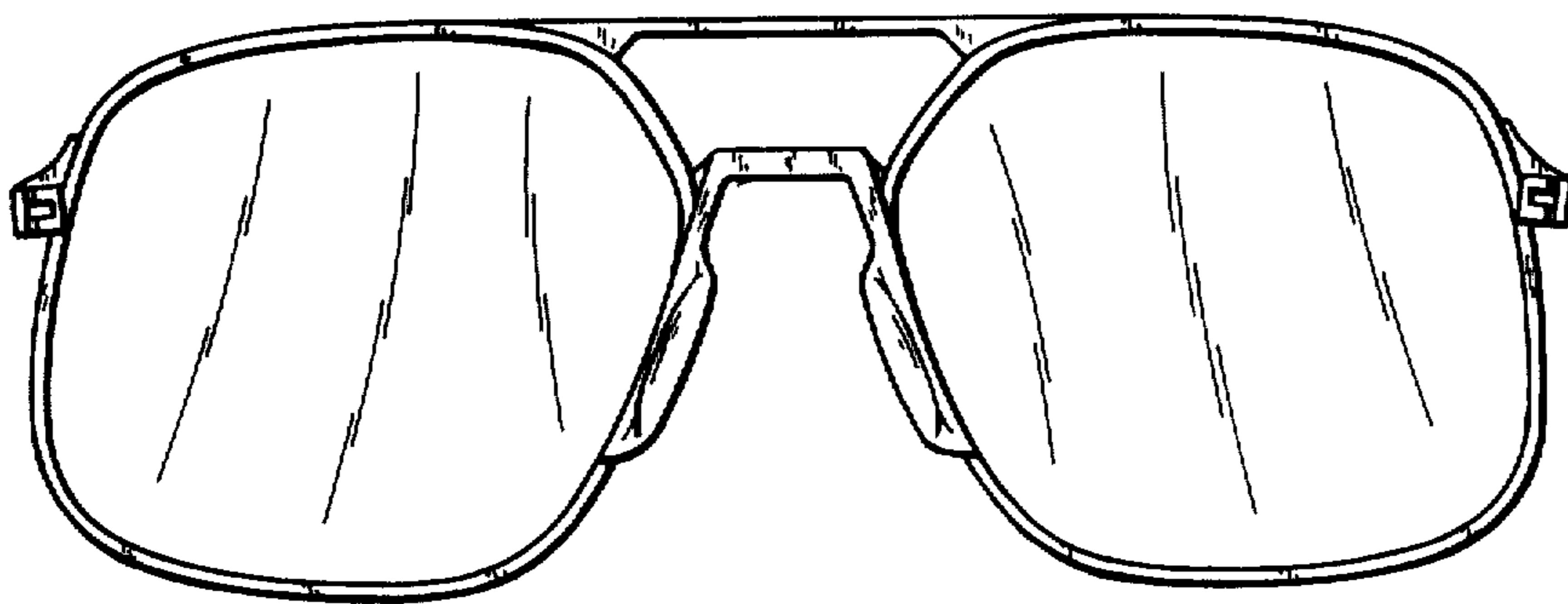

FIG. 8