

[54] MINING VEHICLE

[75] Inventors: John Griffin; T. Daryl Hatch, both of Salt Lake City, Utah

[73] Assignee: Envirotech Corporation, San Mateo, Calif.

[\*\*] Term: 14 Years

[21] Appl. No.: 938,860

[22] Filed: Sep. 1, 1978

[51] Int. Cl. .... D15-04

[52] U.S. Cl. .... D15/21; D15/25

[58] Field of Search .... D15/21, 22, 23, 25; D12/1; 180/77 MC

[56] References Cited

U.S. PATENT DOCUMENTS

- D. 153,638 5/1949 Remde ..... D15/22
- D. 203,668 2/1966 Wagner ..... D15/25

Primary Examiner—James M. Gandy  
Attorney, Agent, or Firm—Robert R. Finch

[57] CLAIM

The ornamental design for a mining vehicle, as shown and described.

DESCRIPTION

FIG. 1 is a perspective view of a mining vehicle showing our new design;

FIG. 2 is a perspective view of the opposite side and front of the vehicle shown in FIG. 1;

FIG. 3 is a top plan view of the vehicle shown in FIG. 1;

FIG. 4 is a side elevational view of the vehicle shown in FIG. 1;

FIG. 5 is a side elevational view of the vehicle shown in FIG. 1 opposite to that shown in FIG. 4;

FIG. 6 is a rear end elevational view of the vehicle shown in FIG. 1;

FIG. 7 is a front end elevational view of the vehicle shown in FIG. 1;

FIG. 8 is a perspective view of a mining vehicle showing a second embodiment of our new design;

FIG. 9 is a top plan view of the vehicle illustrated in FIG. 8;

FIG. 10 is a side elevational view of the vehicle illustrated in FIG. 8;

FIG. 11 is a side elevational view of the vehicle illustrated in FIG. 8 opposite to that shown in FIG. 10;

FIG. 12 is a rear end elevational view of the vehicle illustrated in FIG. 8;

FIG. 13 is a front end elevational view of the vehicle illustrated in FIG. 8.

The broken lines in the drawings are for illustrative purposes only.

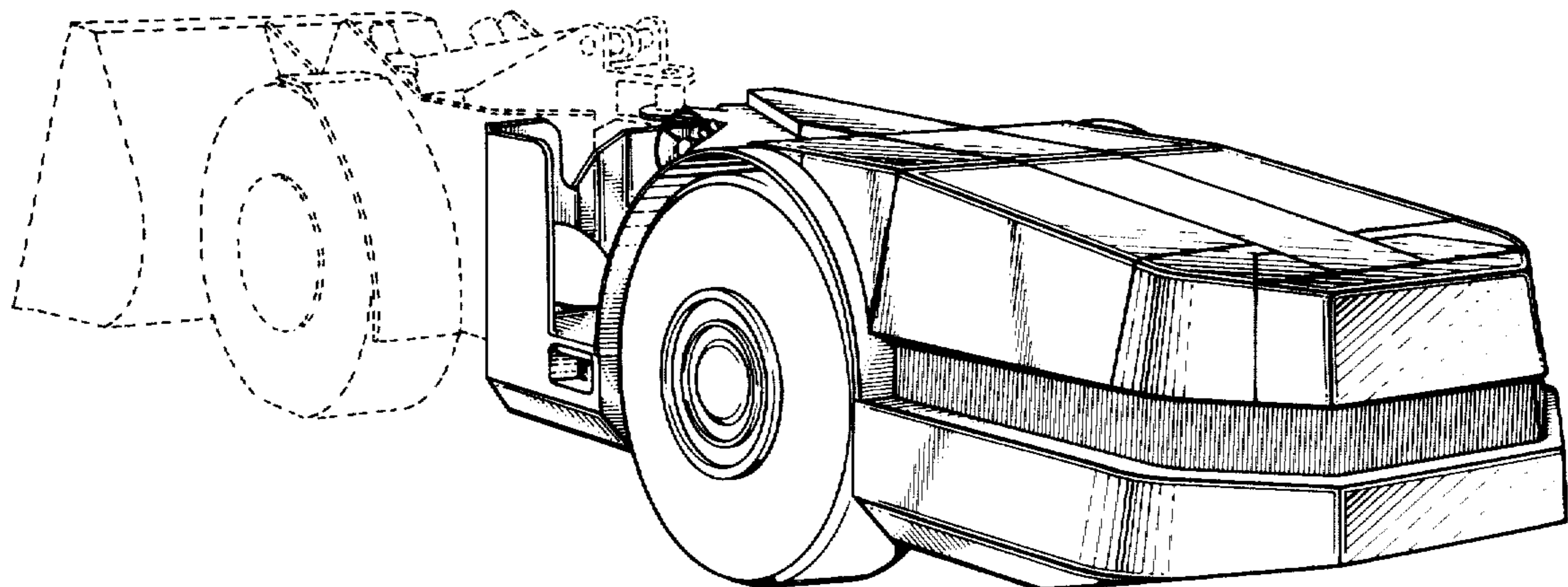

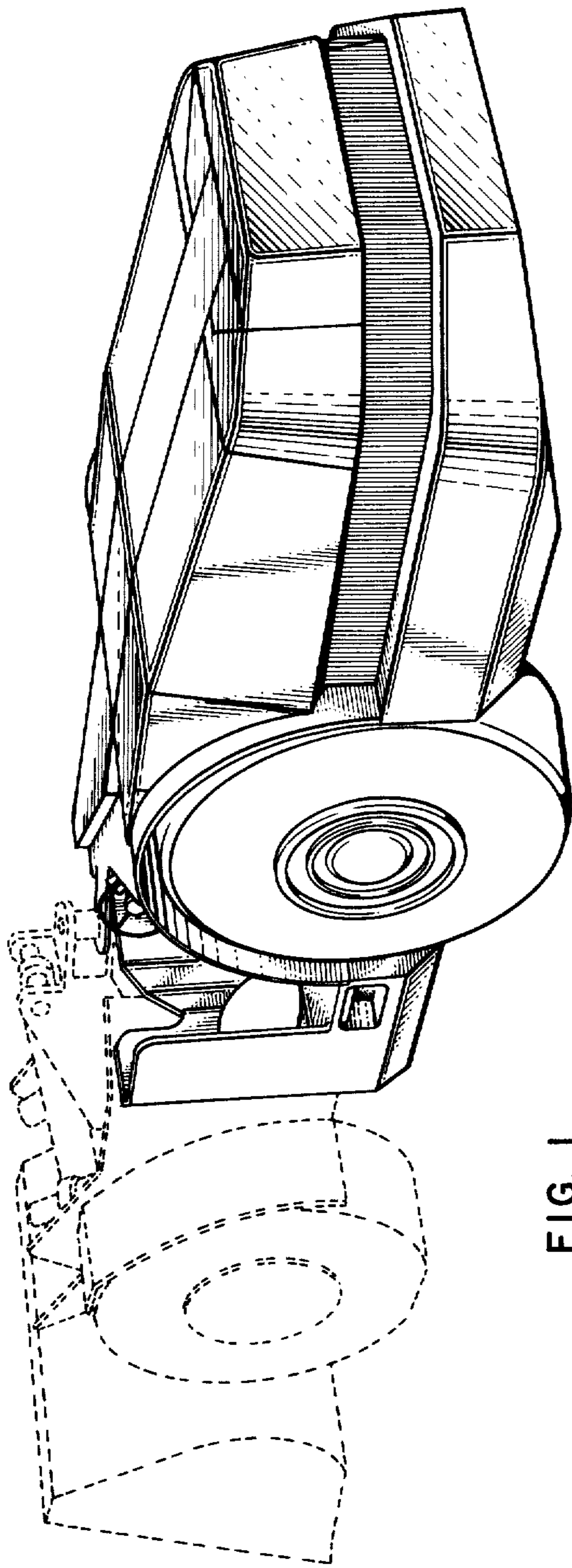

FIG. 1

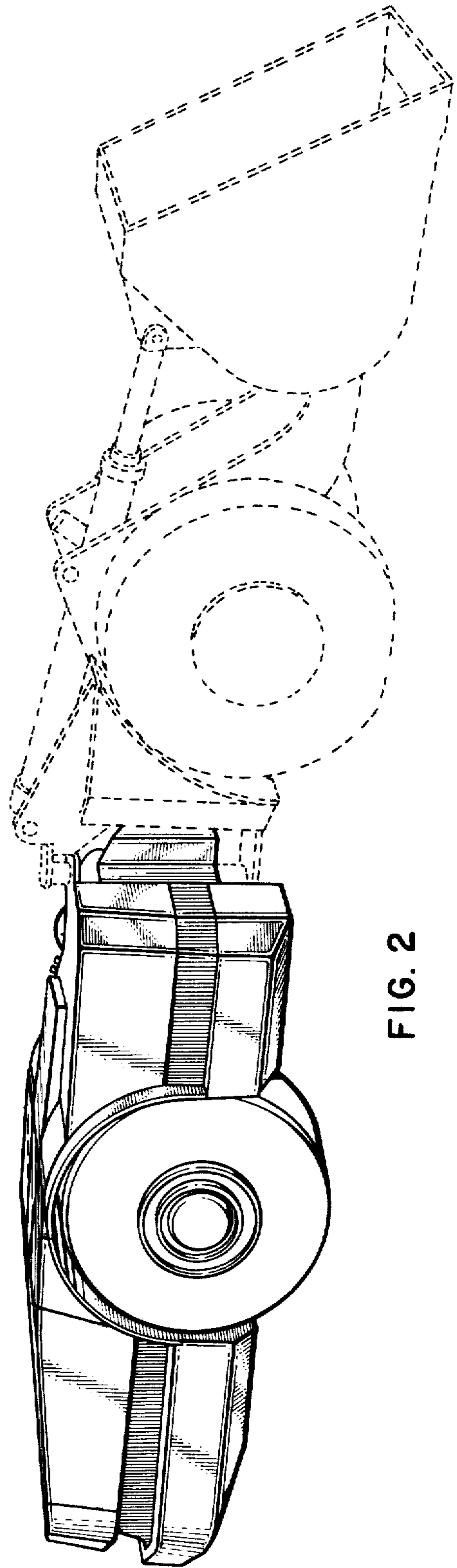

FIG. 2

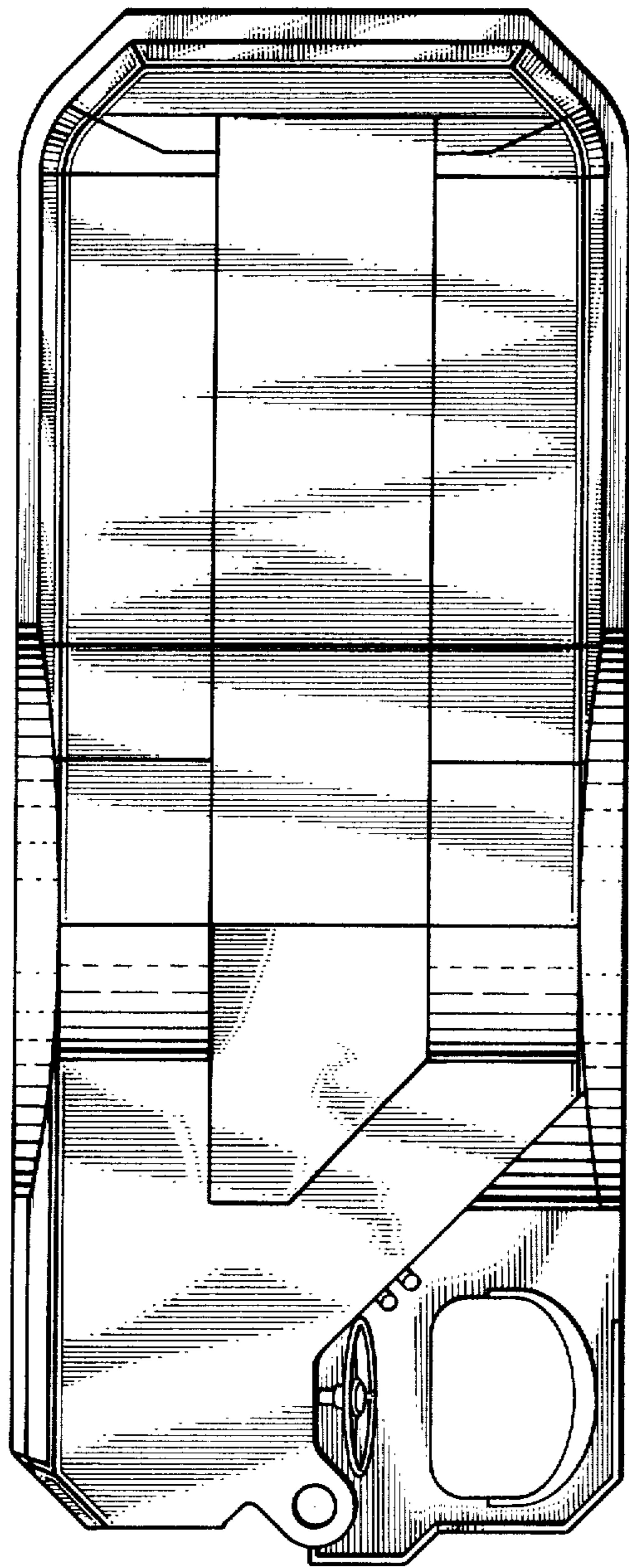

FIG. 3

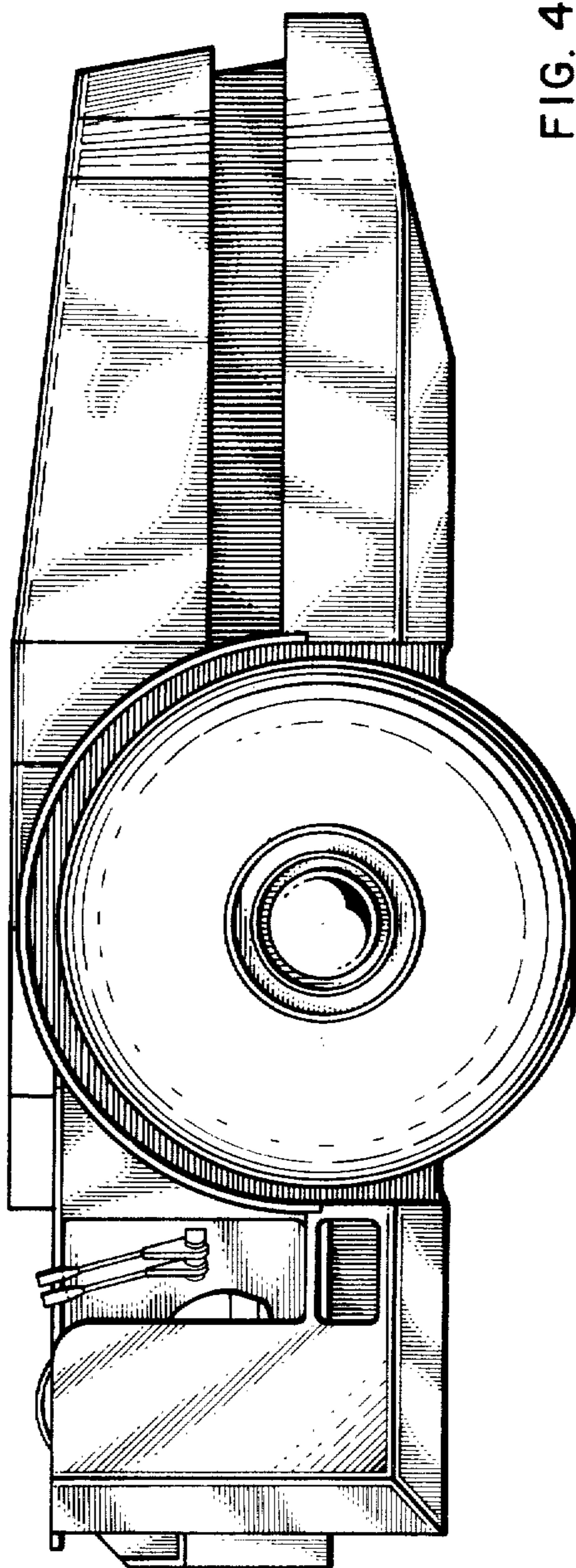

FIG. 4

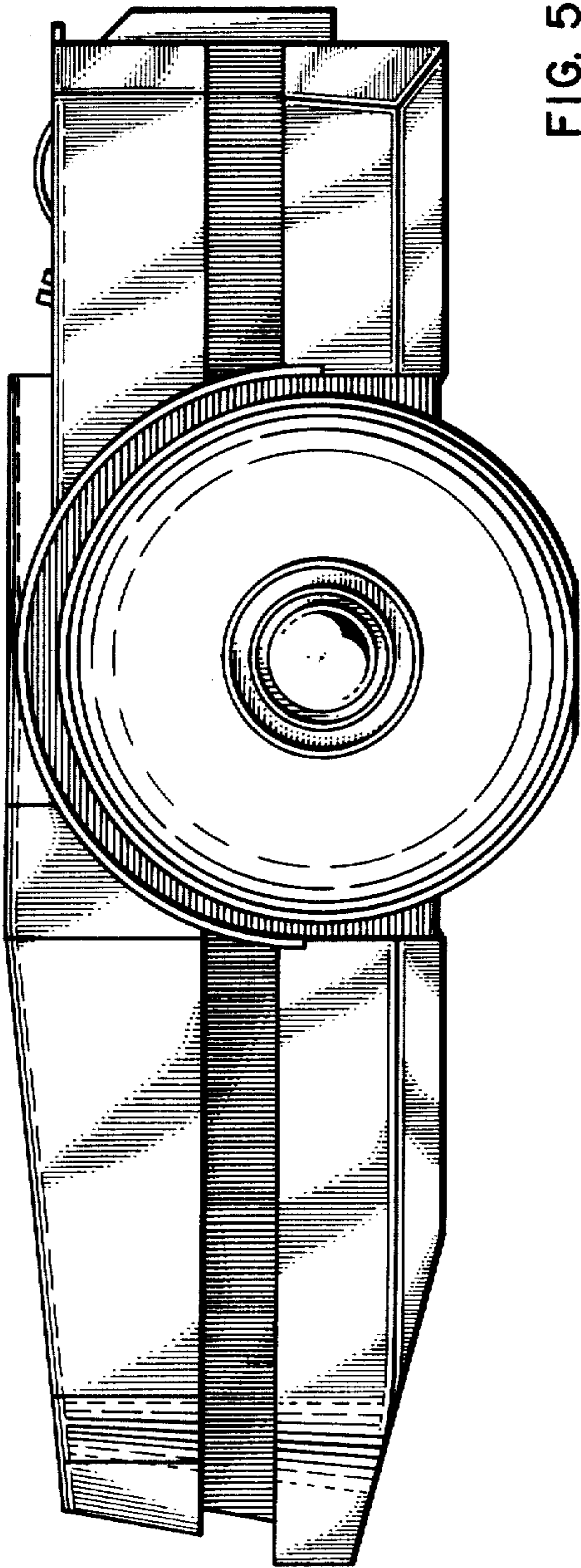

FIG. 5

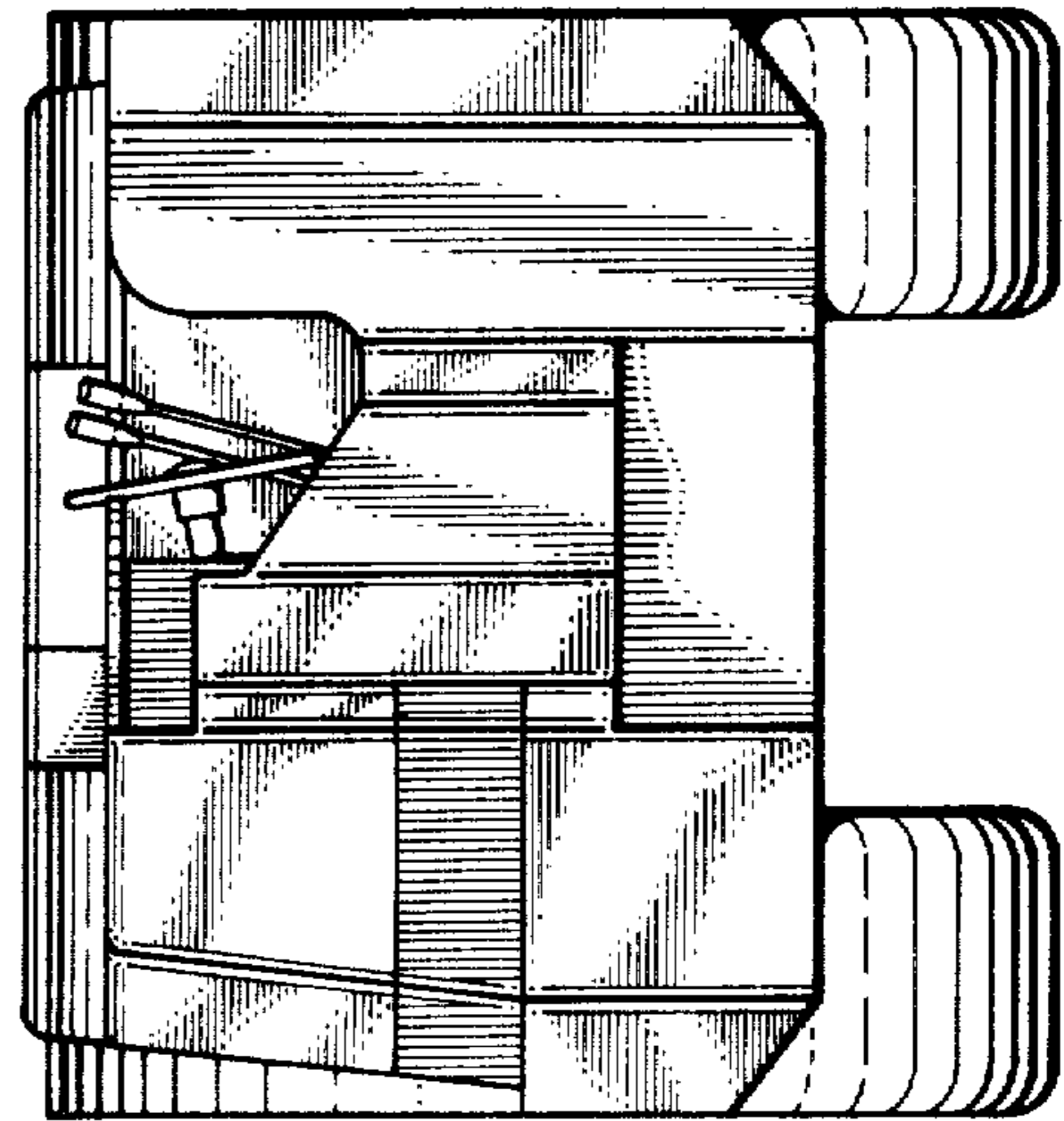

FIG. 7

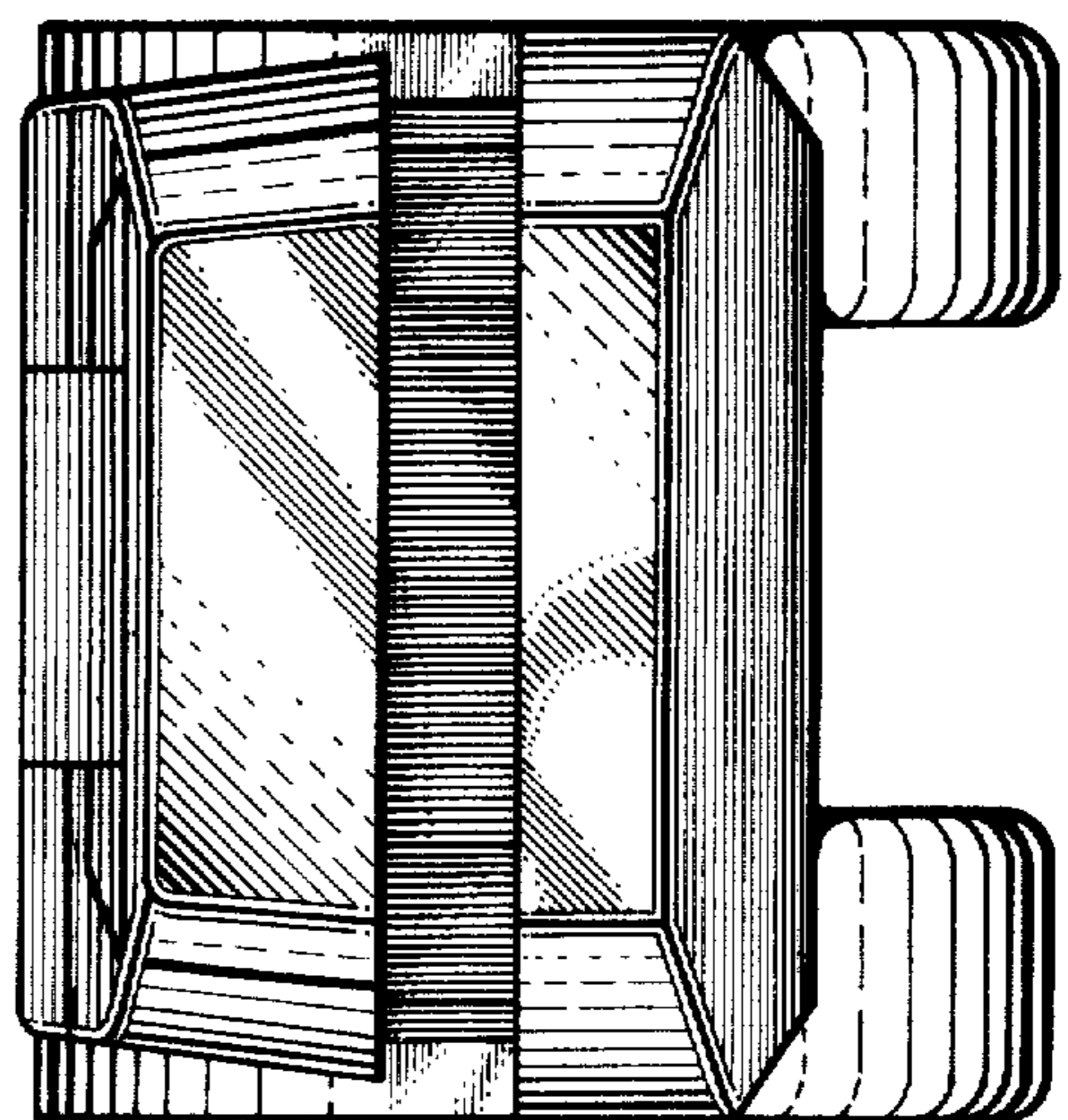

FIG. 6

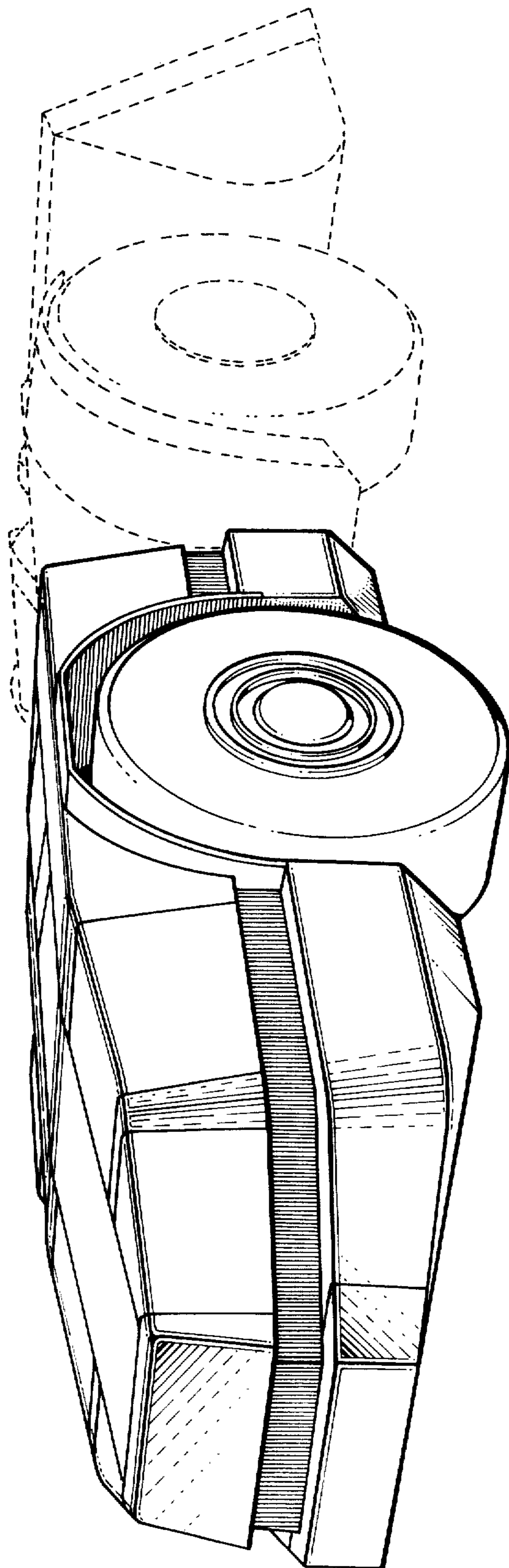

FIG. 8

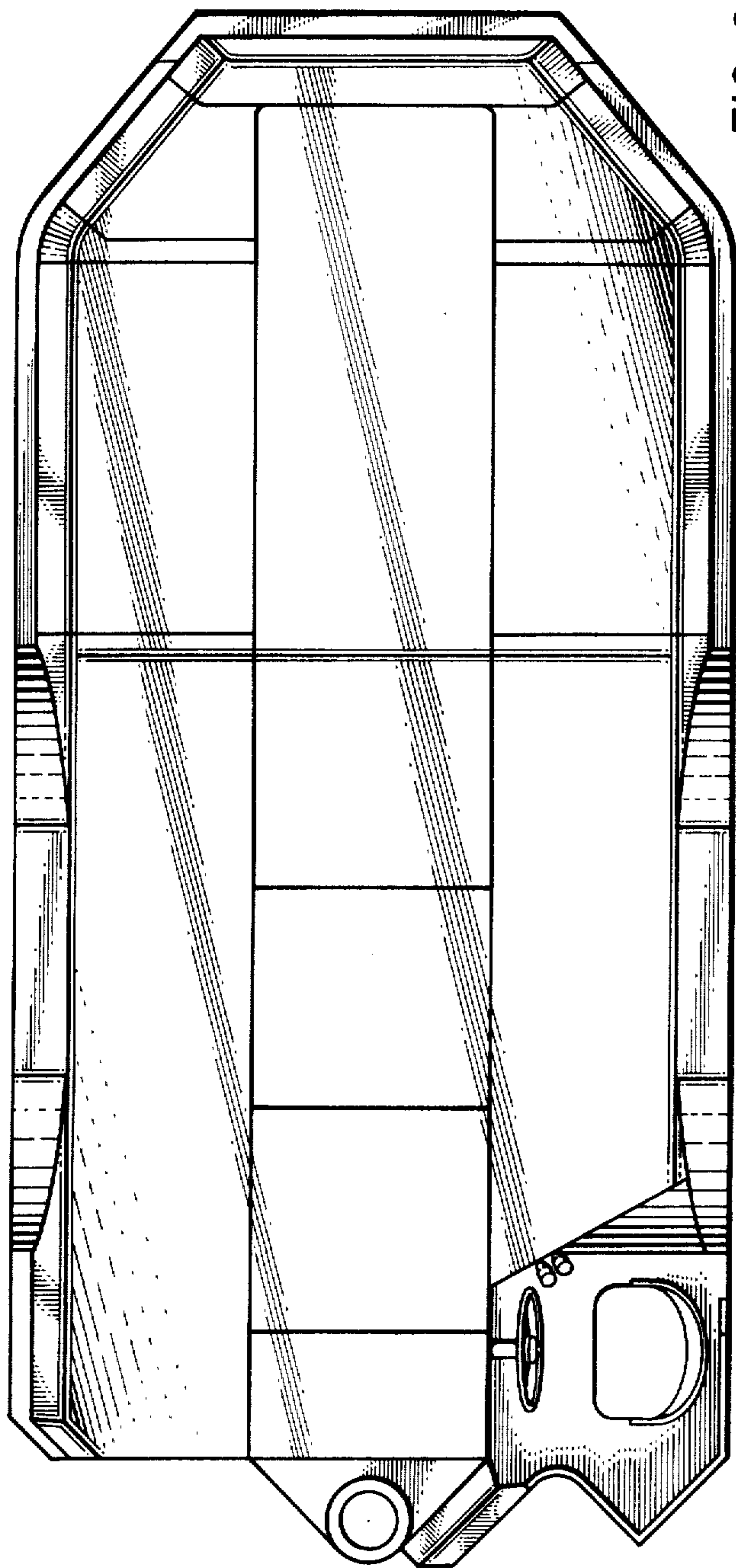

FIG. 9

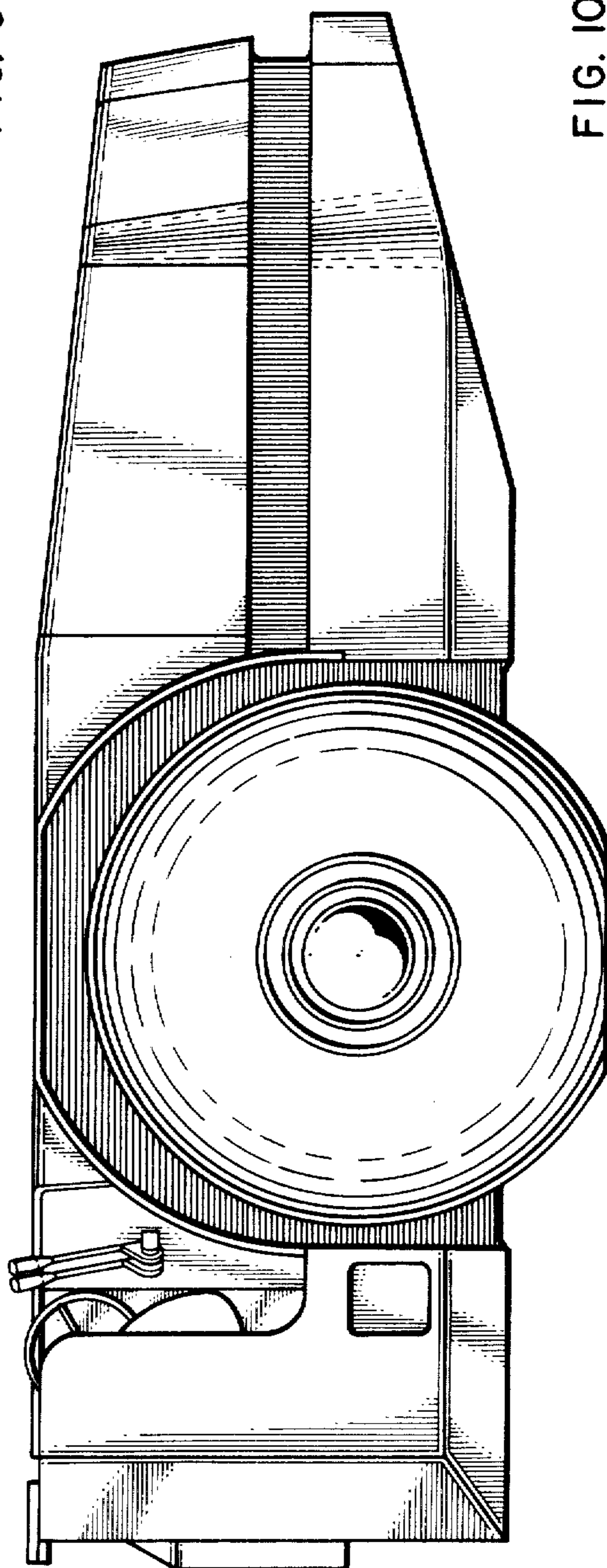

FIG. 10

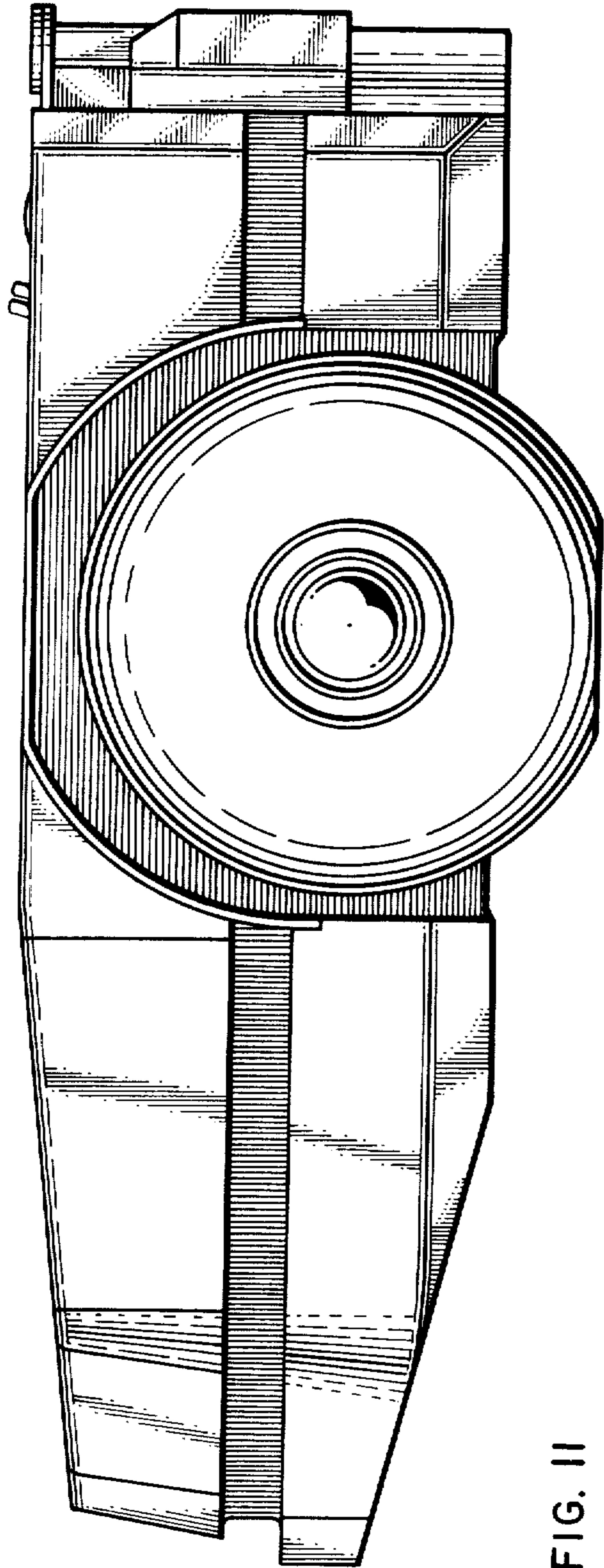

FIG. 11

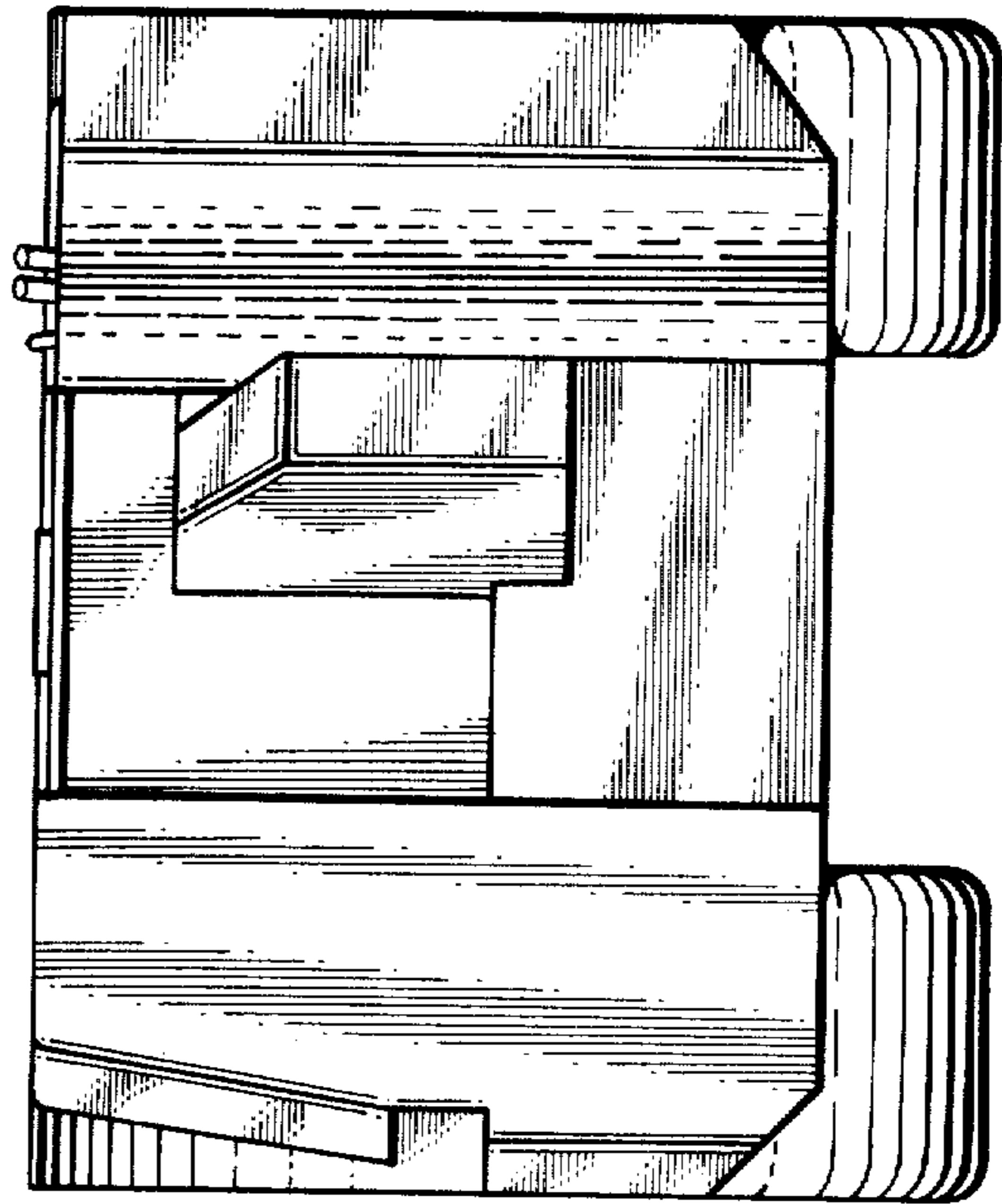

FIG. 13

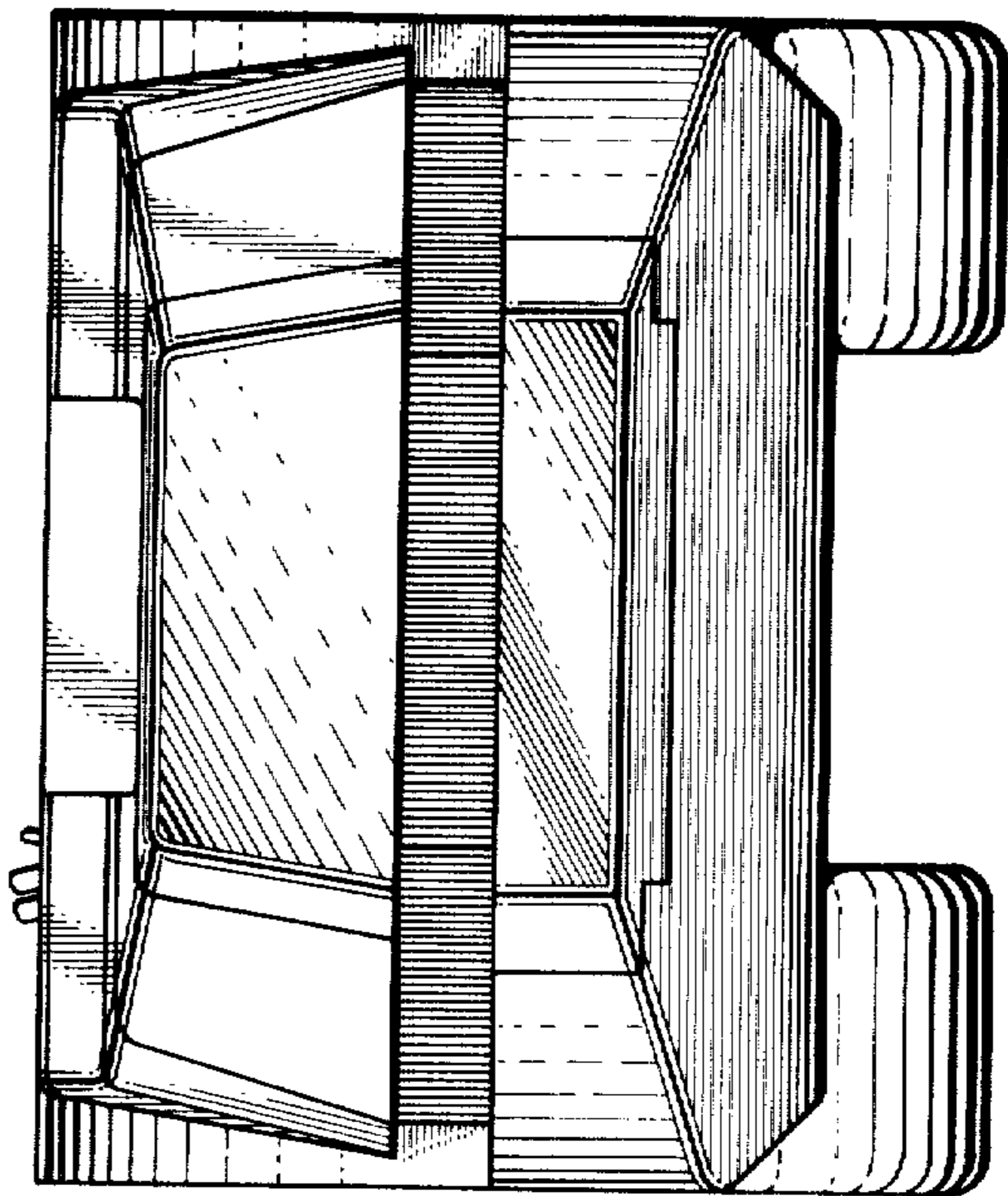

FIG. 12