

[54] ARTICULATED VEHICLE OR THE LIKE

3,191,372 6/1965 Shepley D15/27

[76] Inventors: Robert W. Becker, 5800 McDougal Dr., Fayetteville, N.C. 28304; Keith L. Bradshaw, 1928 W. Hill Dr., Fayetteville, N.C. 28306

[**] Term: 14 Years

[21] Appl. No.: 71,555

[22] Filed: Aug. 31, 1979

[51] Int. Cl. D21-01

[52] U.S. Cl. D21/135; D21/132

[58] Field of Search D15/10, 23, 26, 27; D21/76, 78, 79, 81, 128, 132, 134, 135, 136, 137; 46/201-204, 206, 210, 214, 221, 222, 223

[56] References Cited

U.S. PATENT DOCUMENTS

D. 91,354 1/1934 Gruenberg D21/135

OTHER PUBLICATIONS

Hitz, Jacobs & Kassler Toy Catalog, 1923, p. 34, "Follow-Me Tinker".

Billy & Ruth Toy Catalog, 1949, p. 33, Toy Road Grader.

Primary Examiner—Charles A. Rademaker
Attorney, Agent, or Firm—Mills & Coats

[57] CLAIM

The ornamental design for an articulated vehicle or the like, as shown.

DESCRIPTION

FIG. 1 is a left side elevational view of the articulated vehicle or the like showing my new design; FIG. 2 is a top plan view thereof; FIG. 3 is a front elevational view thereof; FIG. 4 is a right side elevational view thereof; and FIG. 5 is a rear elevational view thereof.

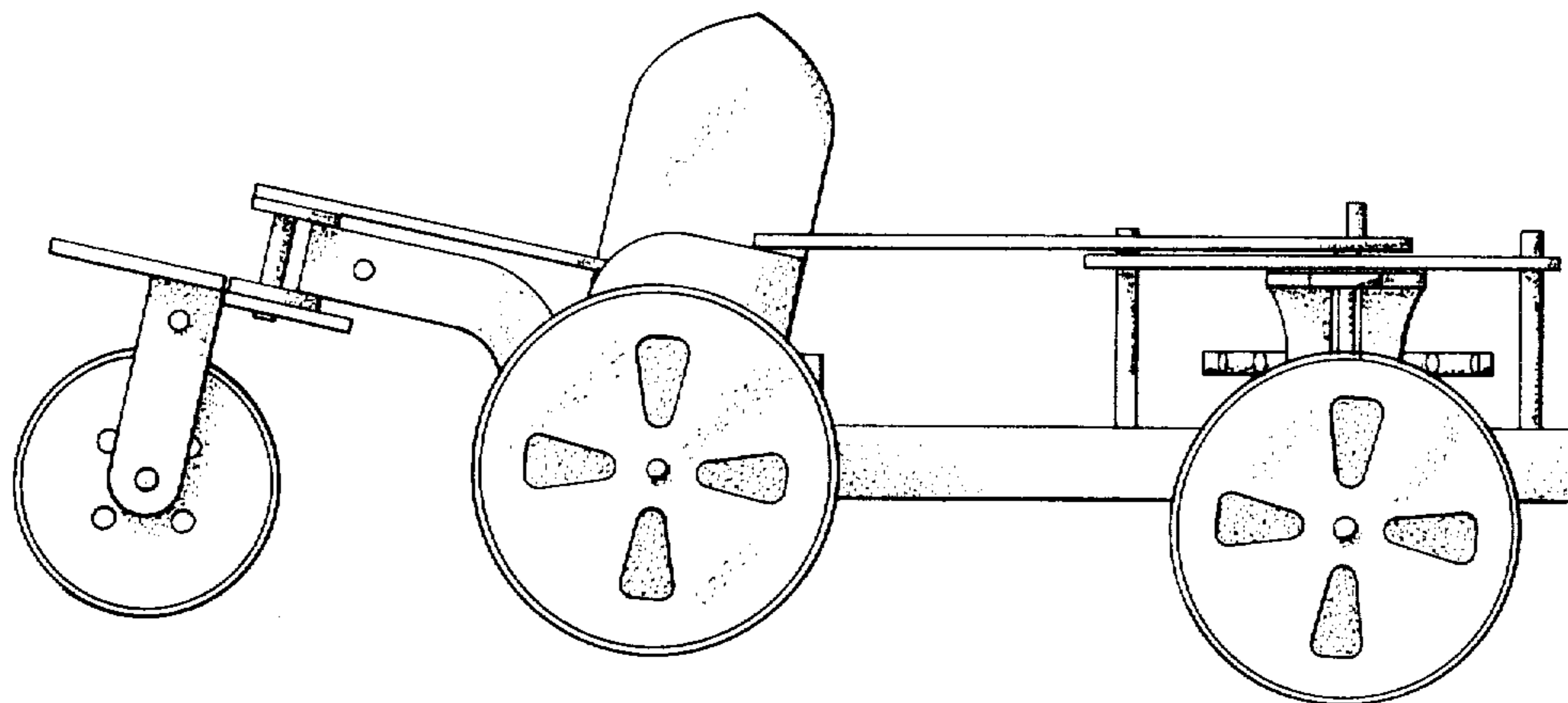

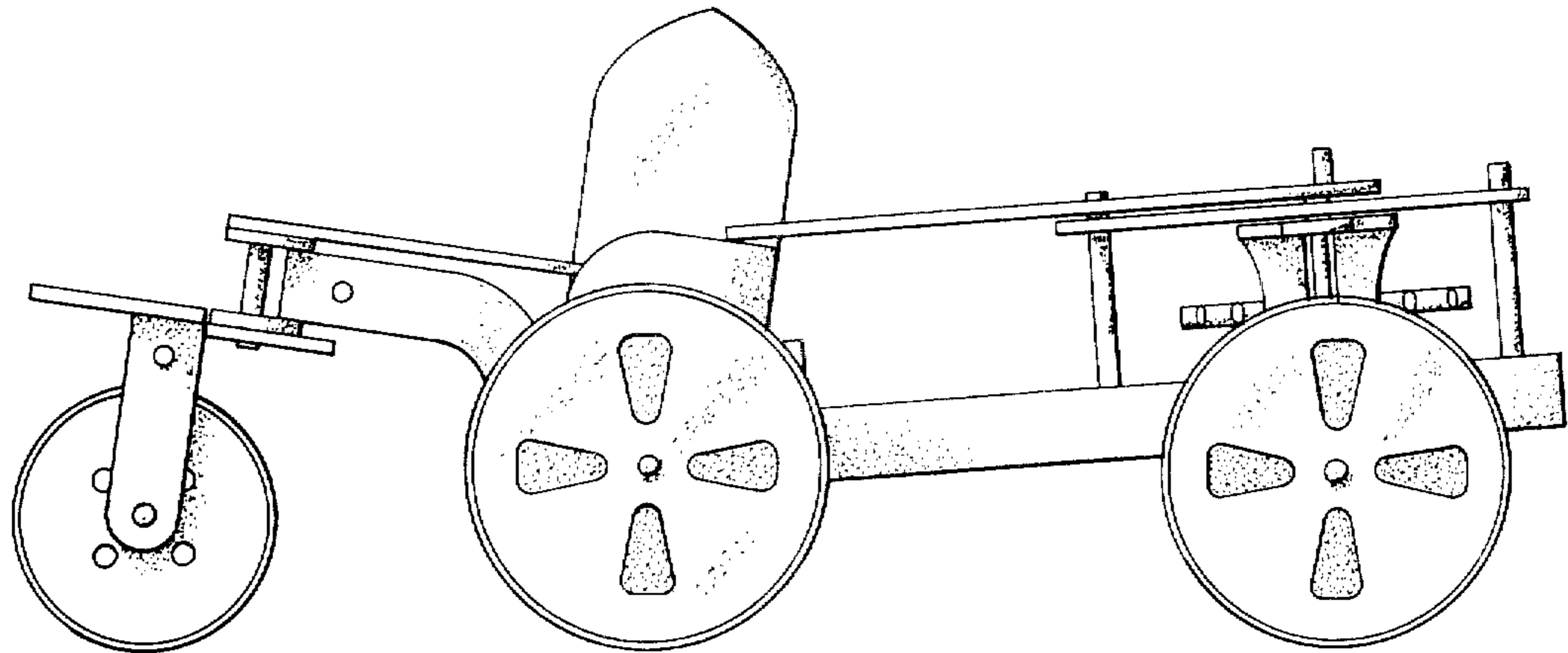

FIG. 1

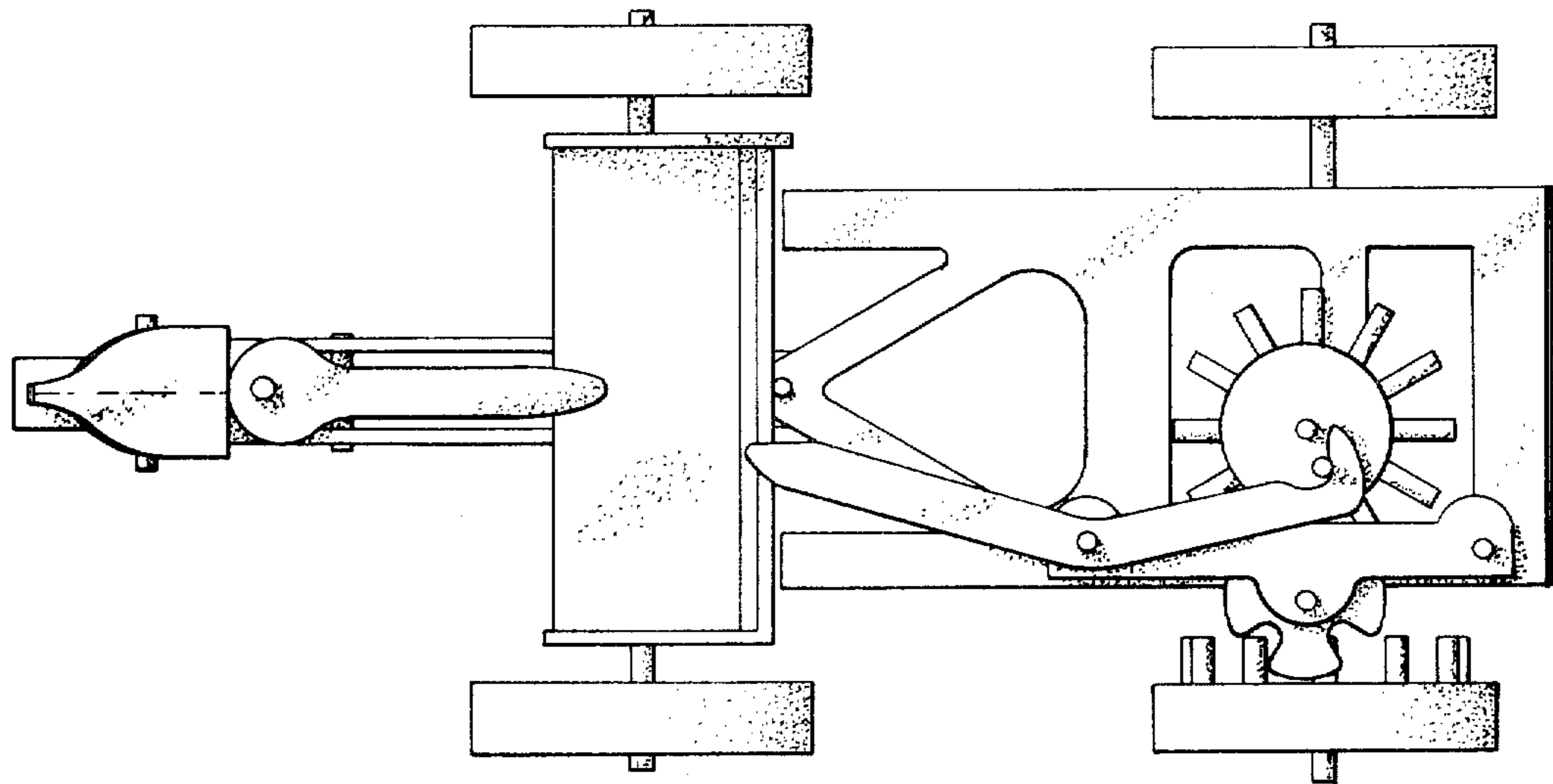

FIG. 2

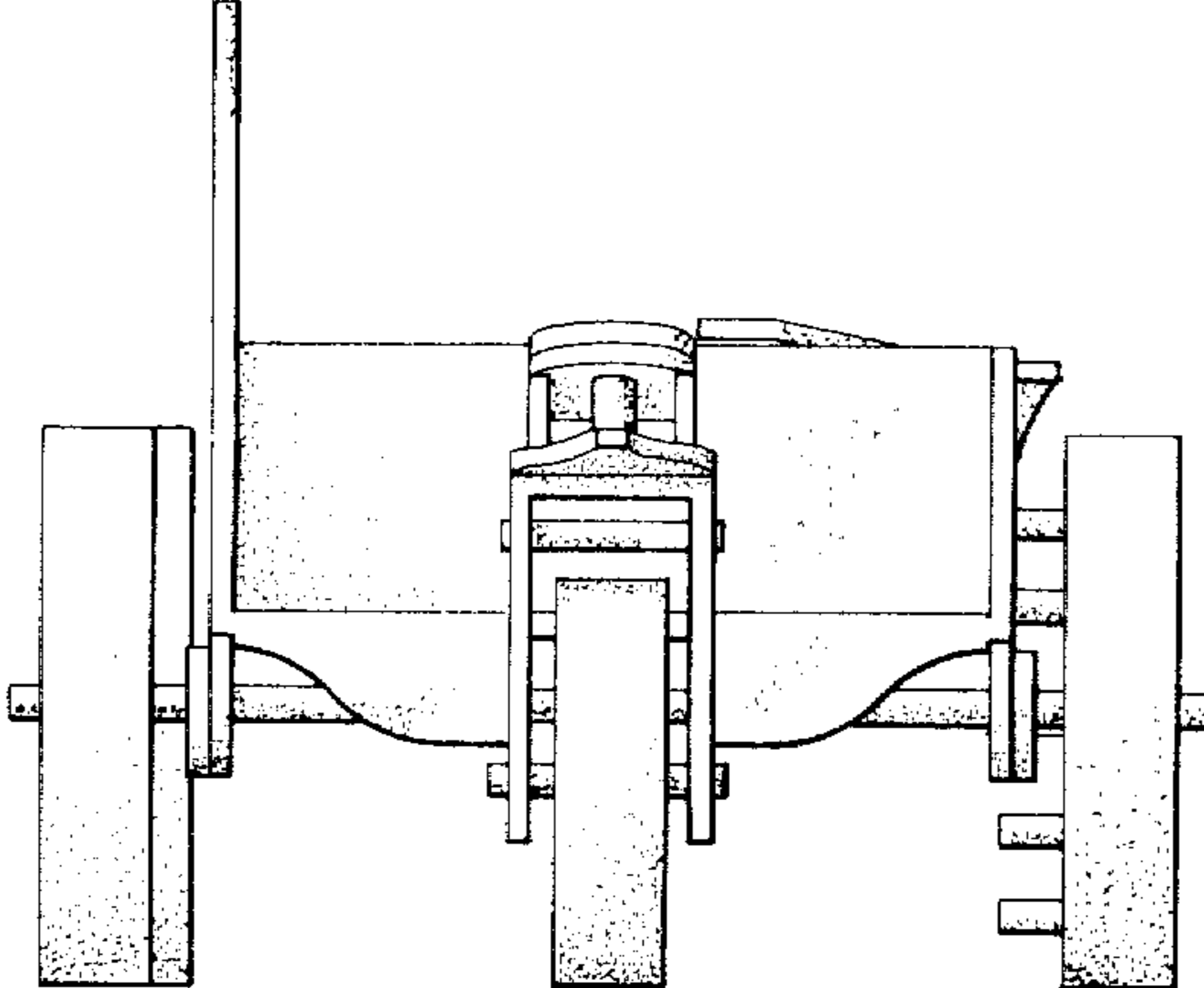

FIG. 3

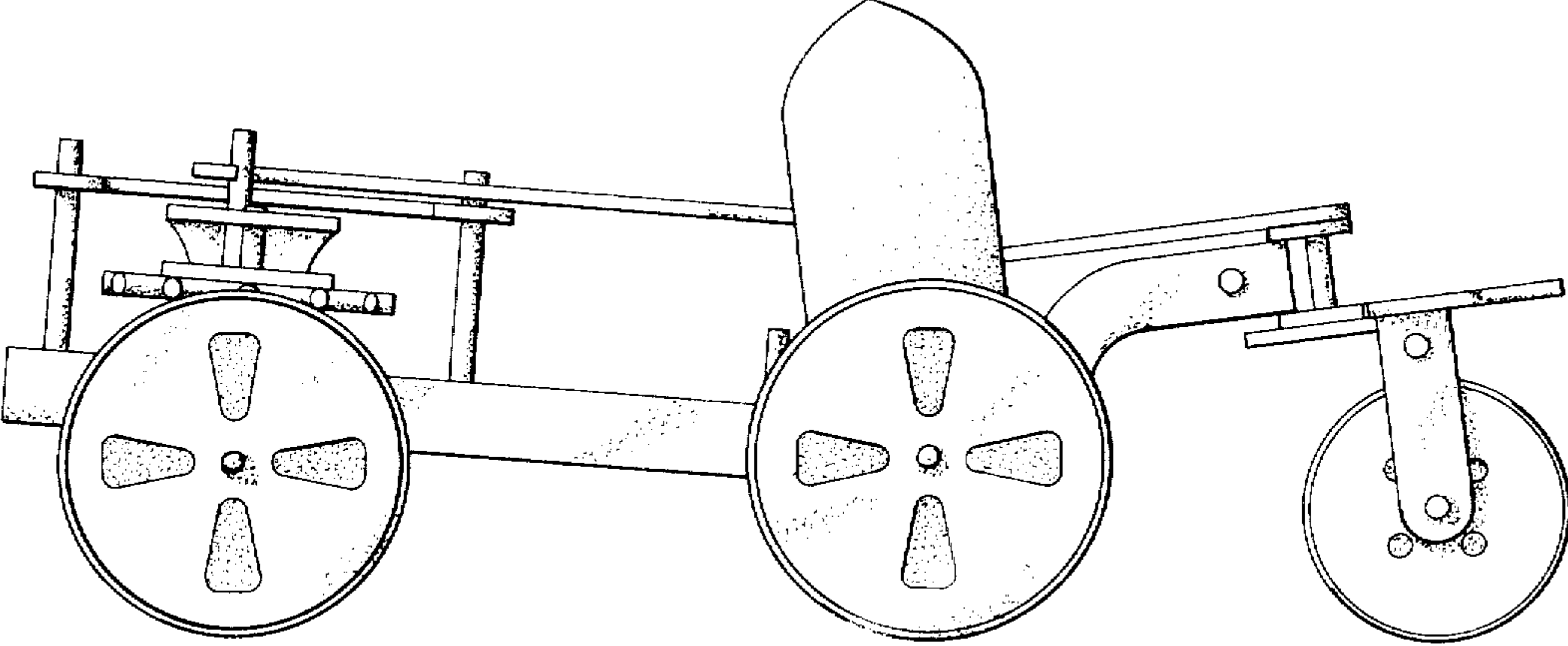

FIG. 4

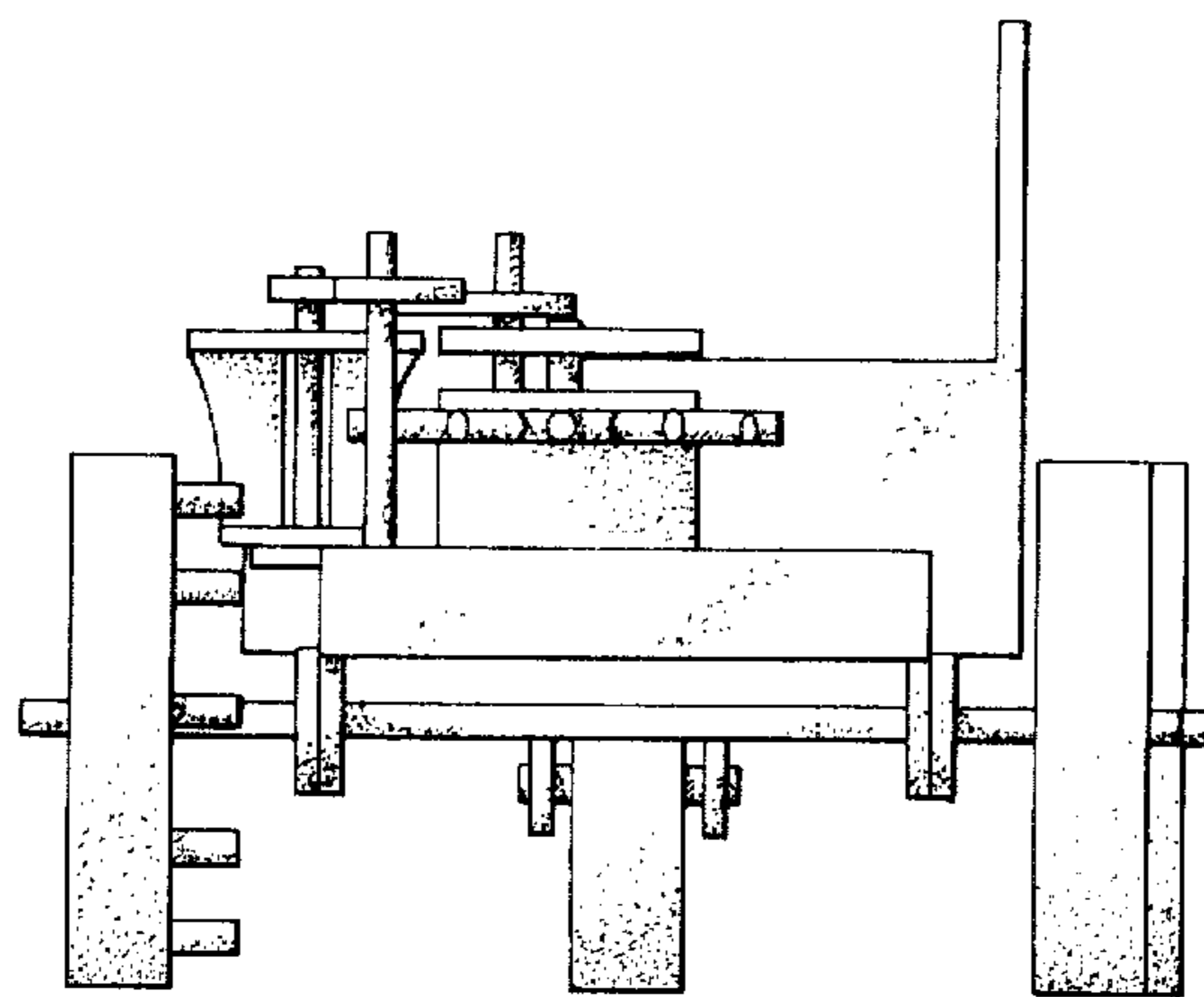

FIG. 5