

[54] VAN

[75] Inventor: **Guido Magrini**, Brescia, Italy

[73] Assignee: **Fiat Veicoli Industriali S.p.A.**, Turin, Italy

[\*\*] Term: **14 Years**

[21] Appl. No.: **940,238**

[22] Filed: **Sep. 7, 1978**

[30] **Foreign Application Priority Data**

Mar. 14, 1978 [IT] Italy ..... 53021

[51] Int. Cl. .... **D12-08**

[52] U.S. Cl. .... **D12/99**

[58] Field of Search ..... **D12/99; 296/185, 183**

[56] **References Cited**  
**PUBLICATIONS**

Commercial Motor, 10/28/77, p. 49, Van, bottom of page.

*Primary Examiner*—James M. Gandy  
*Attorney, Agent, or Firm*—Sughrue, Mion, Zinn, Macpeak and Seas

[57] **CLAIM**

The ornamental design for a van, as shown and described.

**DESCRIPTION**

FIG. 1 is a side elevational view of a van showing my new design, it being understood that the opposite side is substantially a mirror image thereof.

FIG. 2 is a top plan view thereof.

FIG. 3 is a front elevational view thereof.

FIG. 4 is an enlarged perspective view thereof.

FIG. 5 is a rear elevational view thereof.

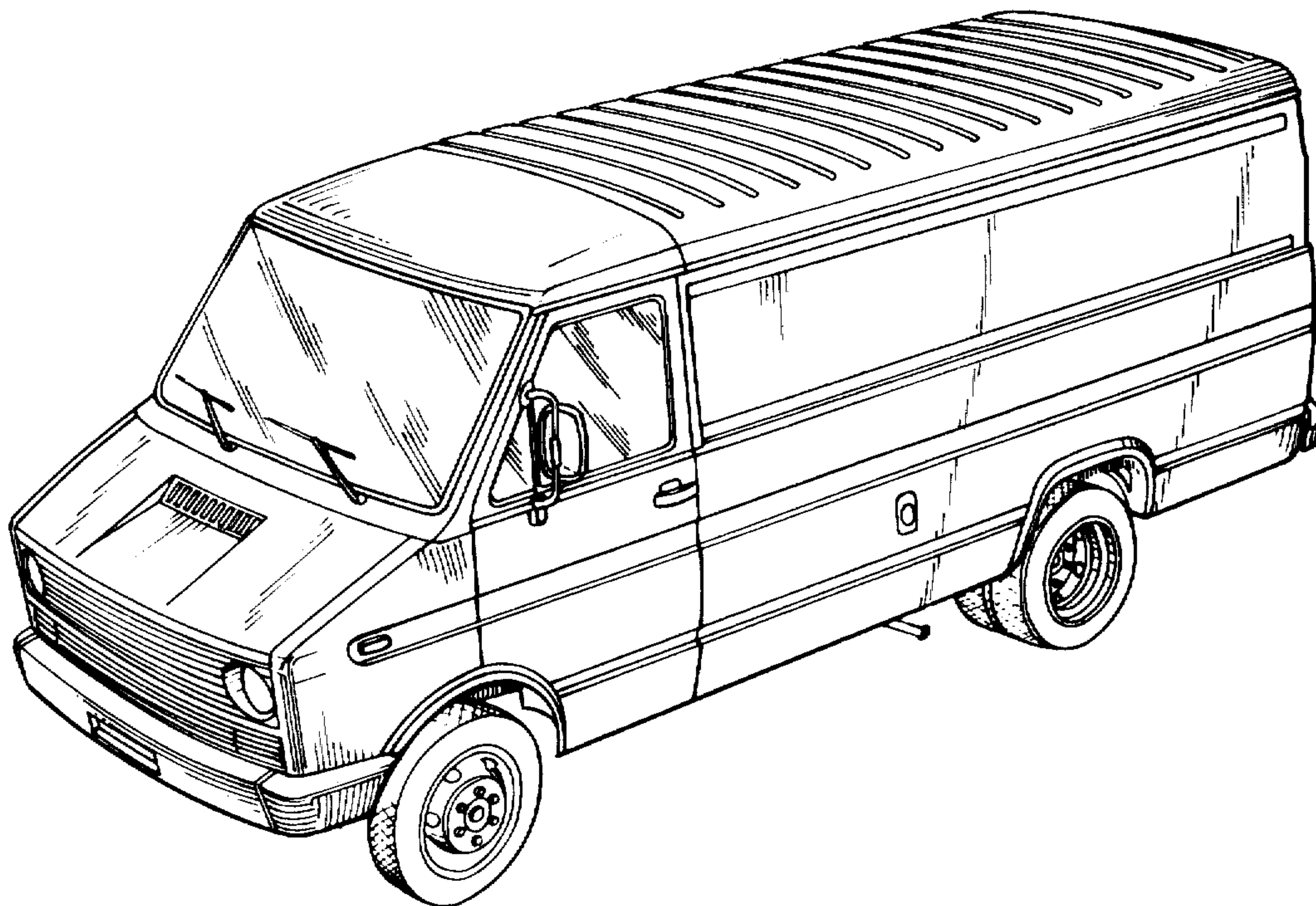

FIG. 1

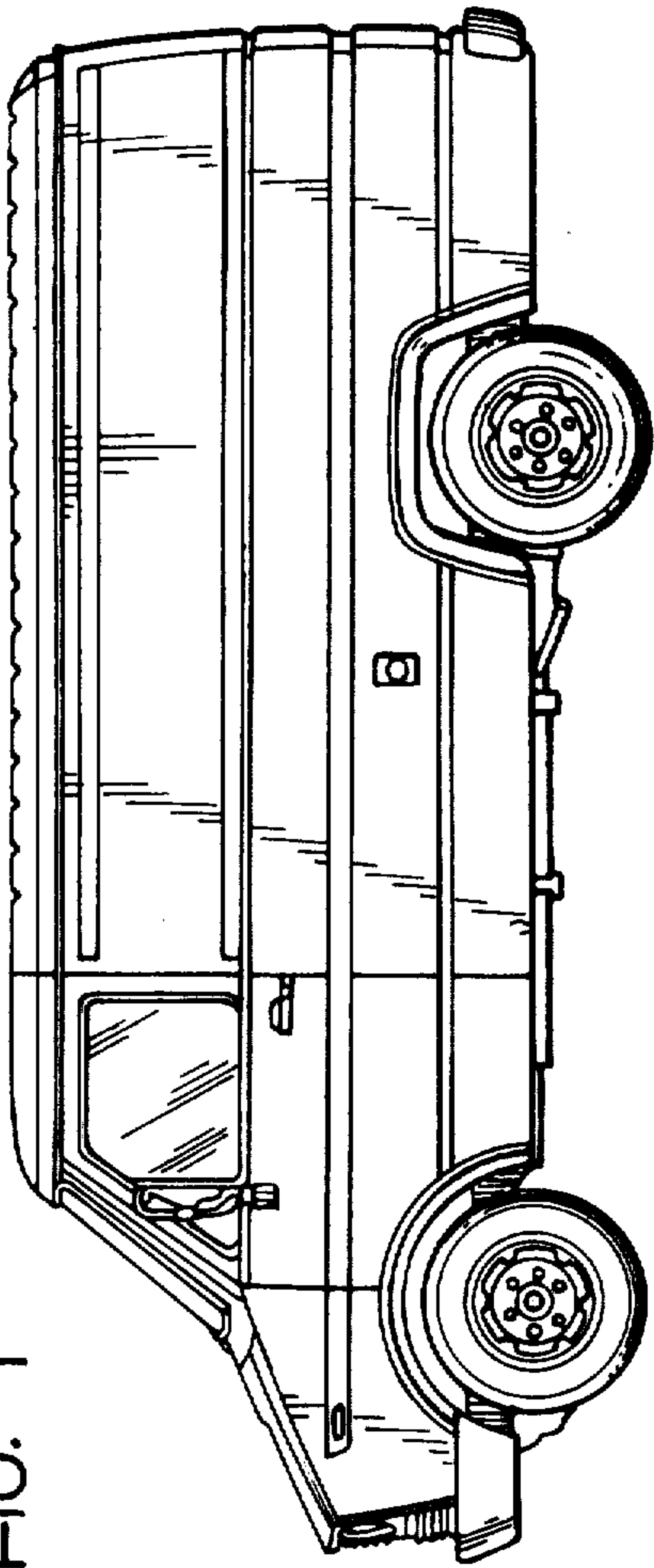

FIG. 3

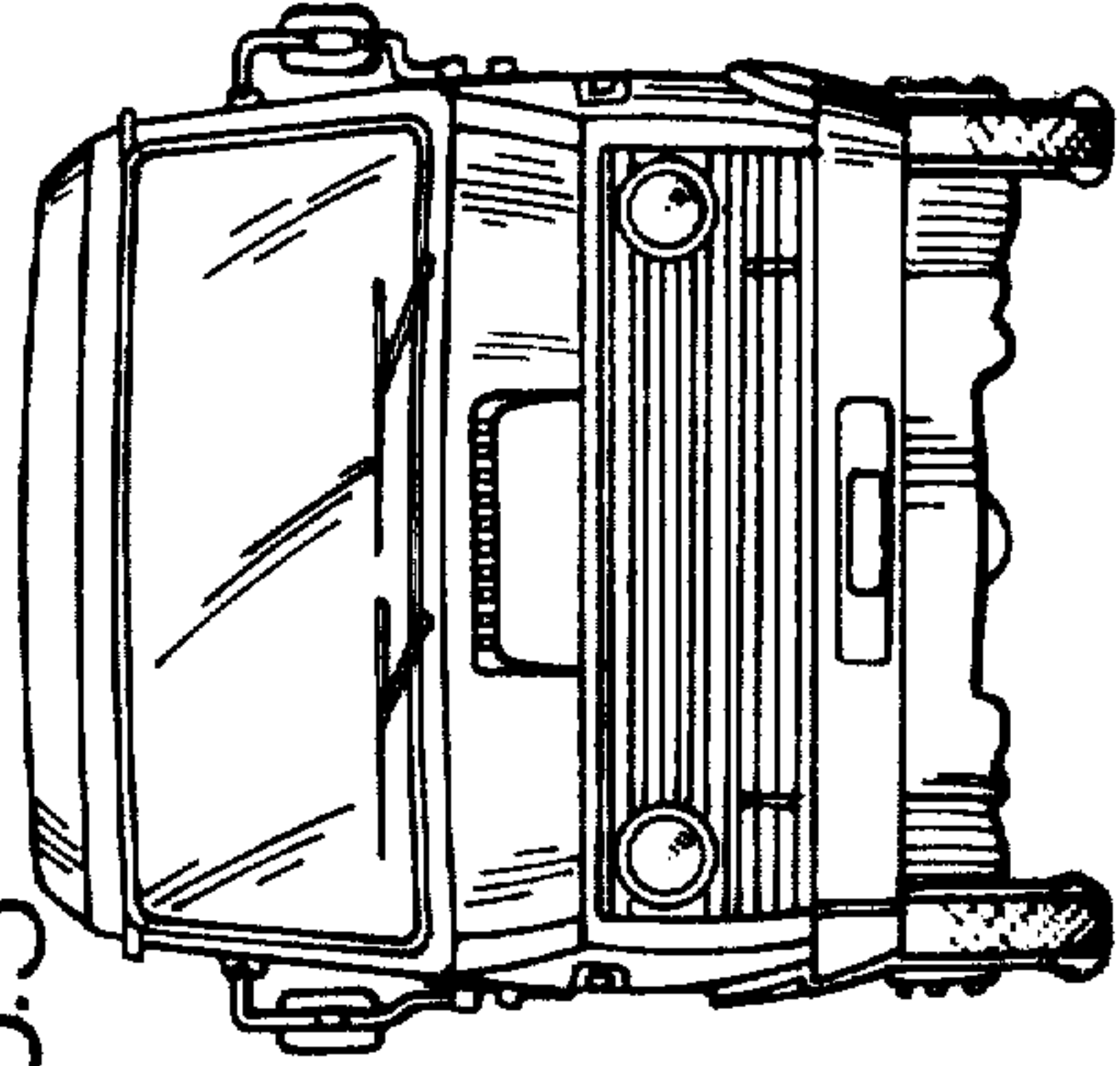

FIG. 2

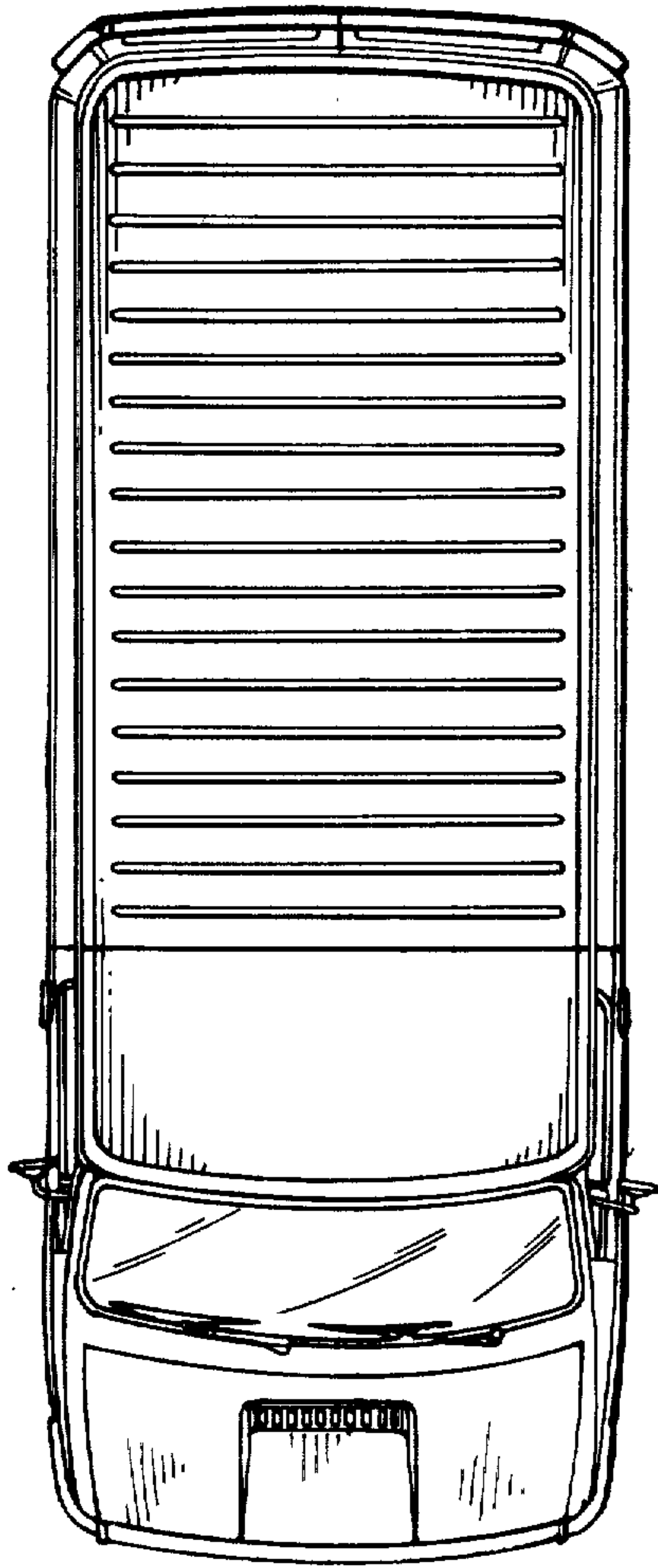
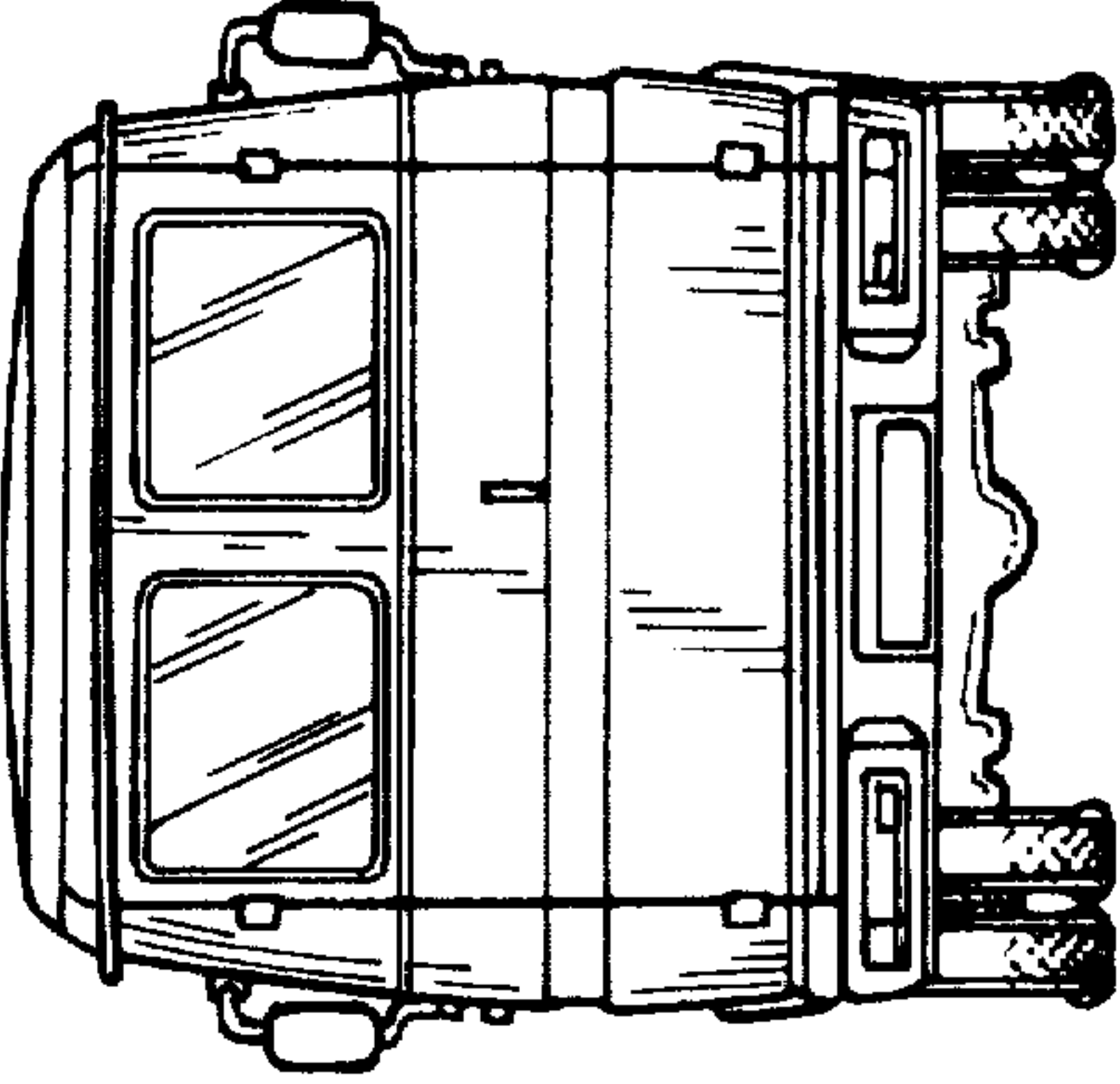

FIG. 5



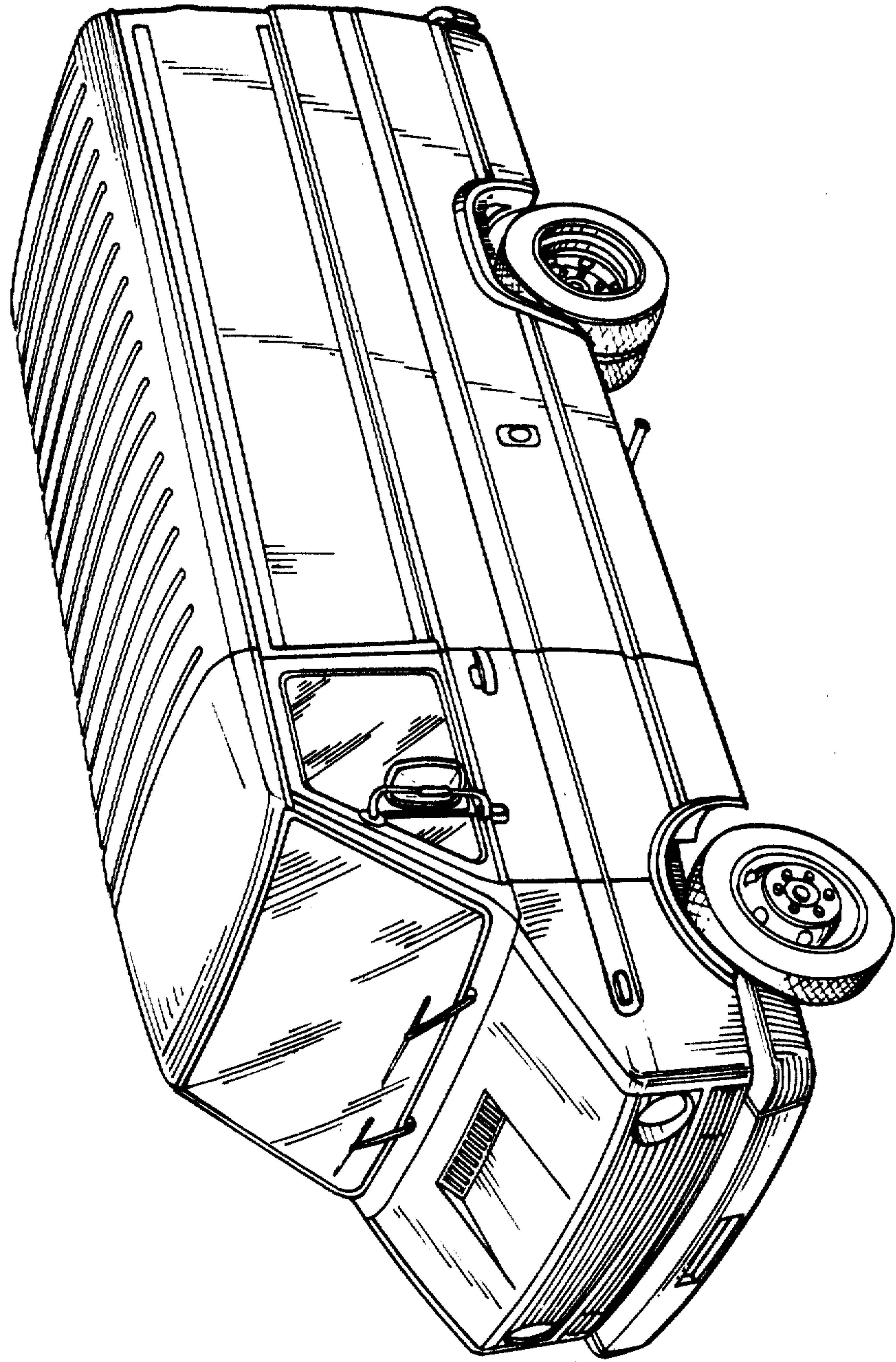

FIG. 4