

[54] **INDUSTRIAL TRUCK**

[75] Inventor: **Kenneth A. Frees, St. Peters, Mo.**
[73] Assignee: **Missouri Research Laboratories Inc.,
St. Charles, Mo.**
[**] Term: **14 Years**
[21] Appl. No.: **958,165**
[22] Filed: **Nov. 6, 1978**

[51] Int. Cl. **D12-05**
[52] U.S. Cl. **D34/34**
[58] Field of Search **D12/57, 56; 280/43.12;
254/2 R, 2 B, 2 C; 187/9 R**

[56] **References Cited**

U.S. PATENT DOCUMENTS

D. 244,439 5/1977 Carr et al. **D12/57**

OTHER PUBLICATIONS

Raymond Bulletin 913, rear cover, Model WL4FR Industrial Truck.
Modern Materials Handling, 4/78, inside front cover, Pallet Truck, center of page.

Primary Examiner—James M. Gandy
Attorney, Agent, or Firm—Kalish and Gilster

[57] **CLAIM**

The ornamental design for an industrial truck, as shown and described.

DESCRIPTION

FIG. 1 is a perspective view of an industrial truck showing my new design.
FIG. 2 is a side elevational view thereof the opposite being substantially a mirror image of the side shown.
FIG. 3 is a top plan view thereof.
FIG. 4 is a bottom plan view thereof.
FIG. 5 is a front elevational view thereof.
FIG. 6 is a rear elevational view thereof.

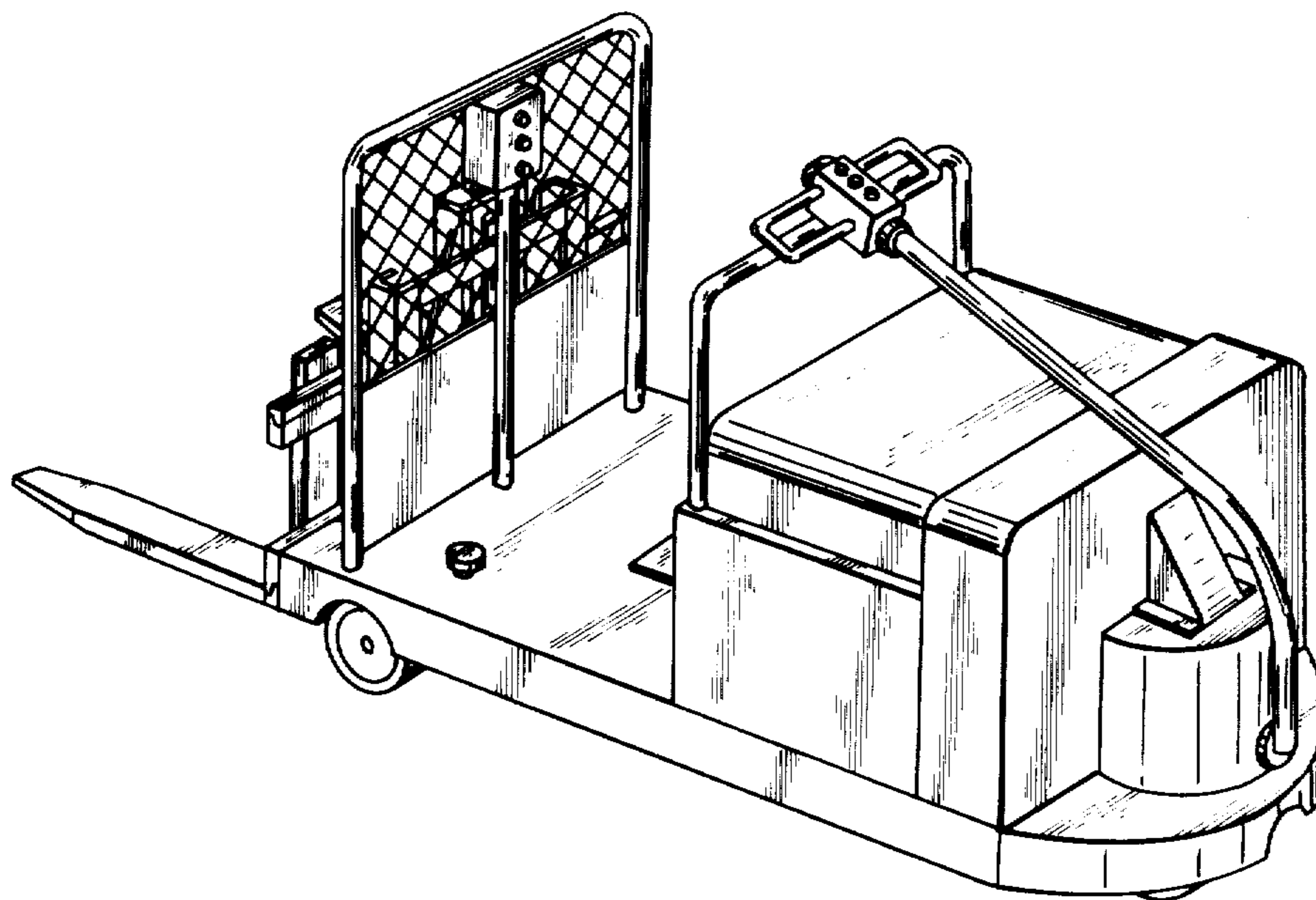

FIG. 1

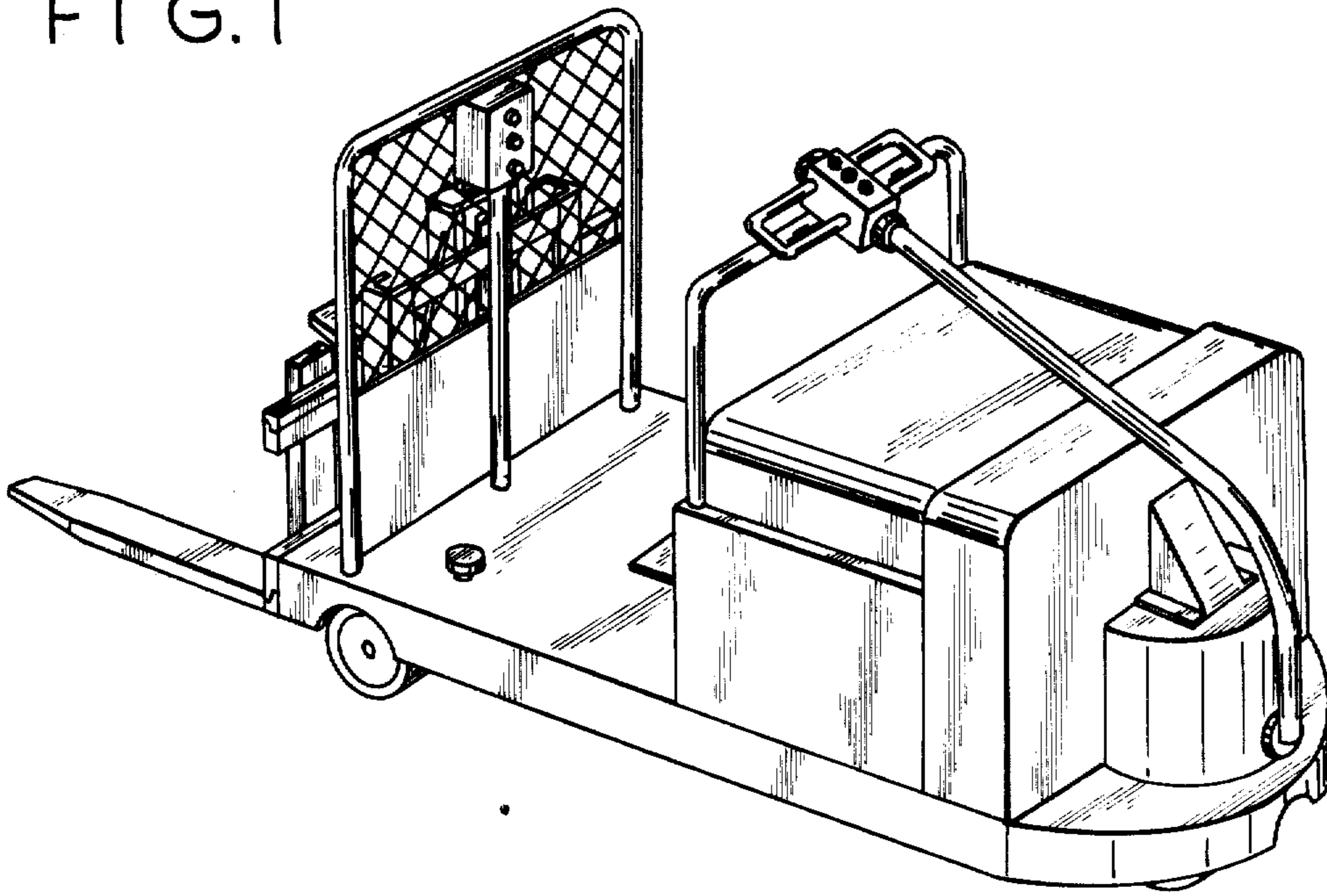

FIG. 2

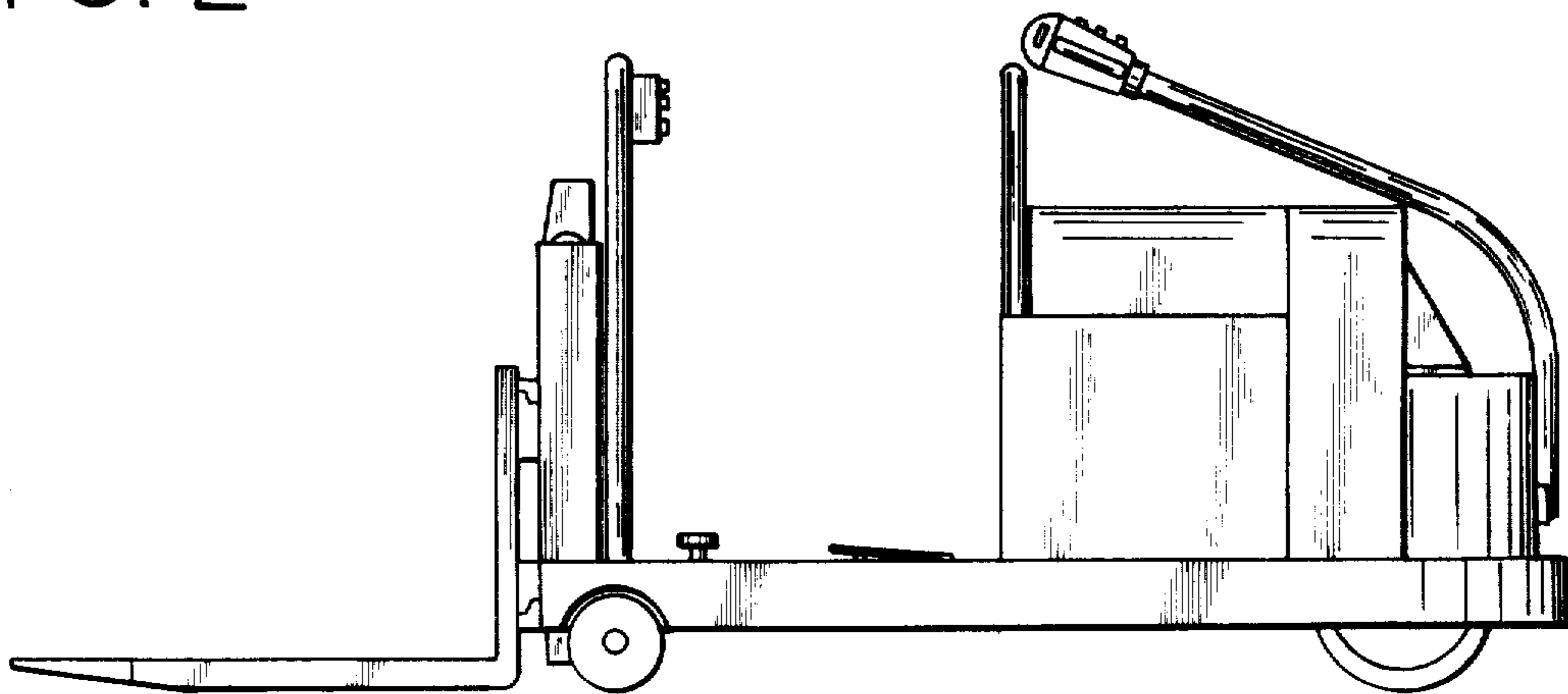

FIG. 3

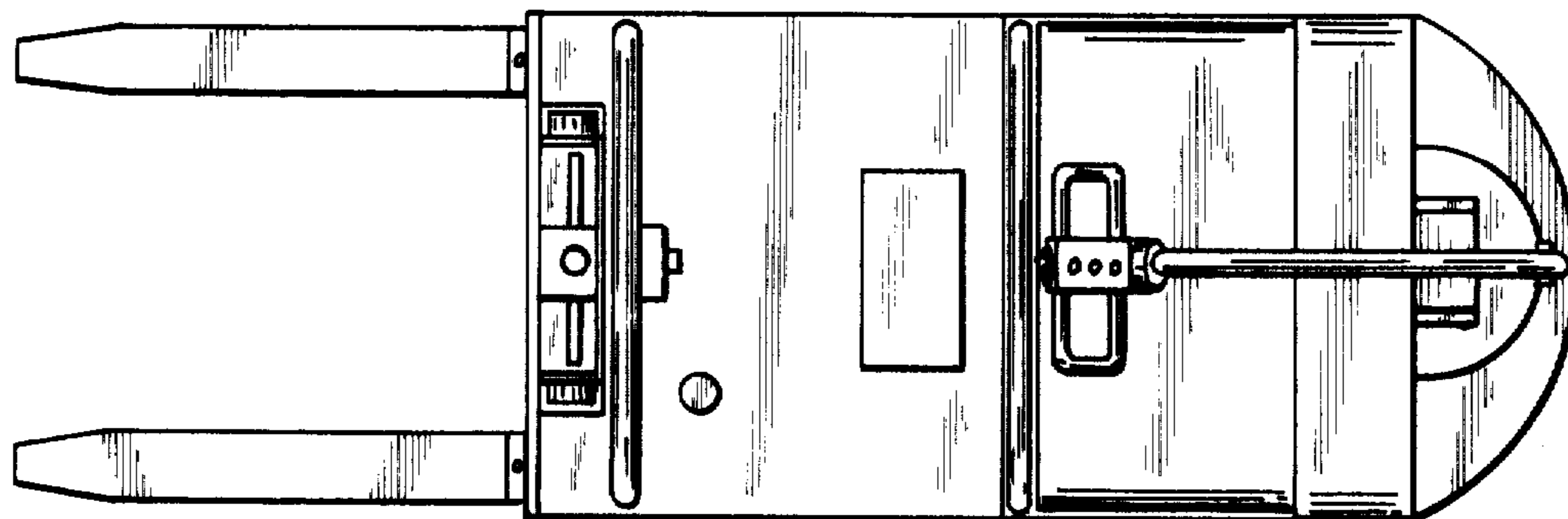

FIG. 4

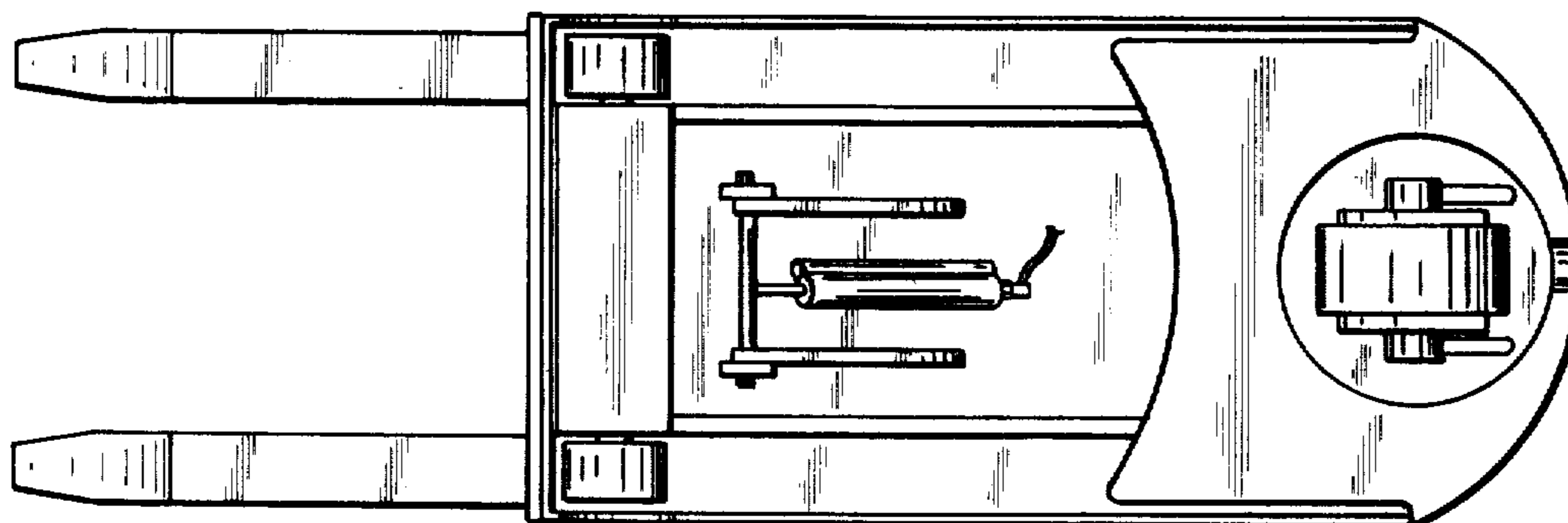

FIG. 5

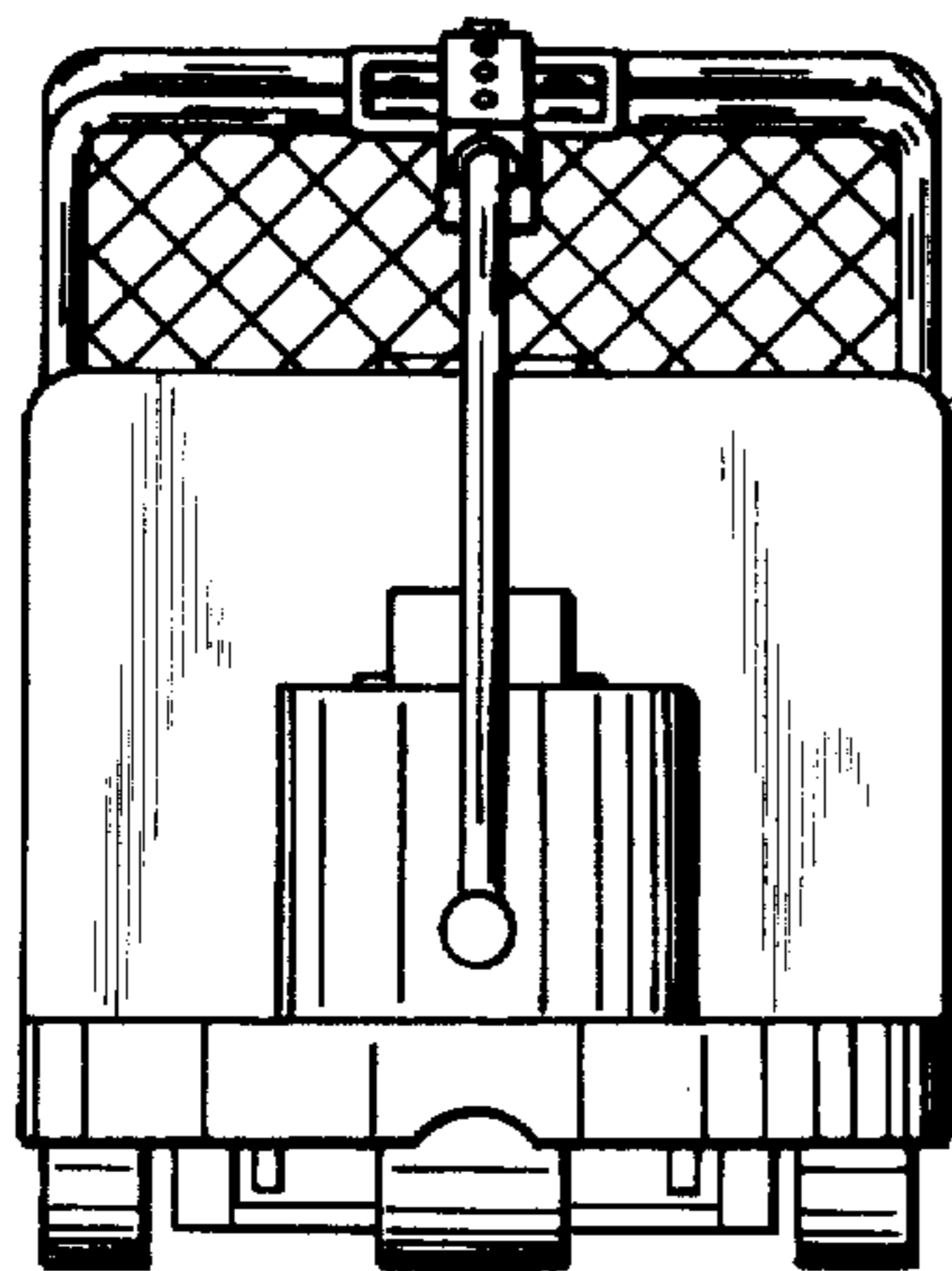

FIG. 6

