

[54] COMBINED TOY SPORTS CAR AND FIGURE THEREFOR

[75] Inventor: Naoharu Yamashina, Tokyo, Japan

[73] Assignee: Kabushiki Kaisha Bandai Overseas, Tokyo, Japan

[**] Term: 14 Years

[21] Appl. No.: 9,053

[22] Filed: Feb. 5, 1979

[30] Foreign Application Priority Data

Aug. 10, 1978 [JP] Japan 53-33915

[51] Int. Cl. D21-01

[52] U.S. Cl. D21/136; D21/137

[58] Field of Search D21/71, 76, 78, 79, D21/80, 128, 134, 140, 150, 166, 137, 136; 46/201, 202, 222, 116, 115, 97, 101, 100

[56] References Cited

U.S. PATENT DOCUMENTS

- D. 149,928 6/1948 Berger D21/134
- D. 192,930 5/1962 Doe D21/137
- D. 246,676 12/1977 Nakao D21/137

OTHER PUBLICATIONS

Gabriel Catalog, 1975, p. 28, Toy Vehicles at bottom left corner of page.

Primary Examiner—Charles A. Rademaker
Attorney, Agent, or Firm—McAulay, Fields, Fisher, Goldstein & Nissen

[57] CLAIM

The ornamental design for a combined toy sports car and figure therefor, as shown and described.

DESCRIPTION

FIG. 1 is a right side elevational view of a combined toy sports car and figure therefor showing my new design, the side opposite being substantially a mirror image; FIG. 2 is a front elevational view thereof; FIG. 3 is a rear elevational view thereof; FIG. 4 is a top plan view thereof; and, FIG. 5 is a bottom plan view thereof.

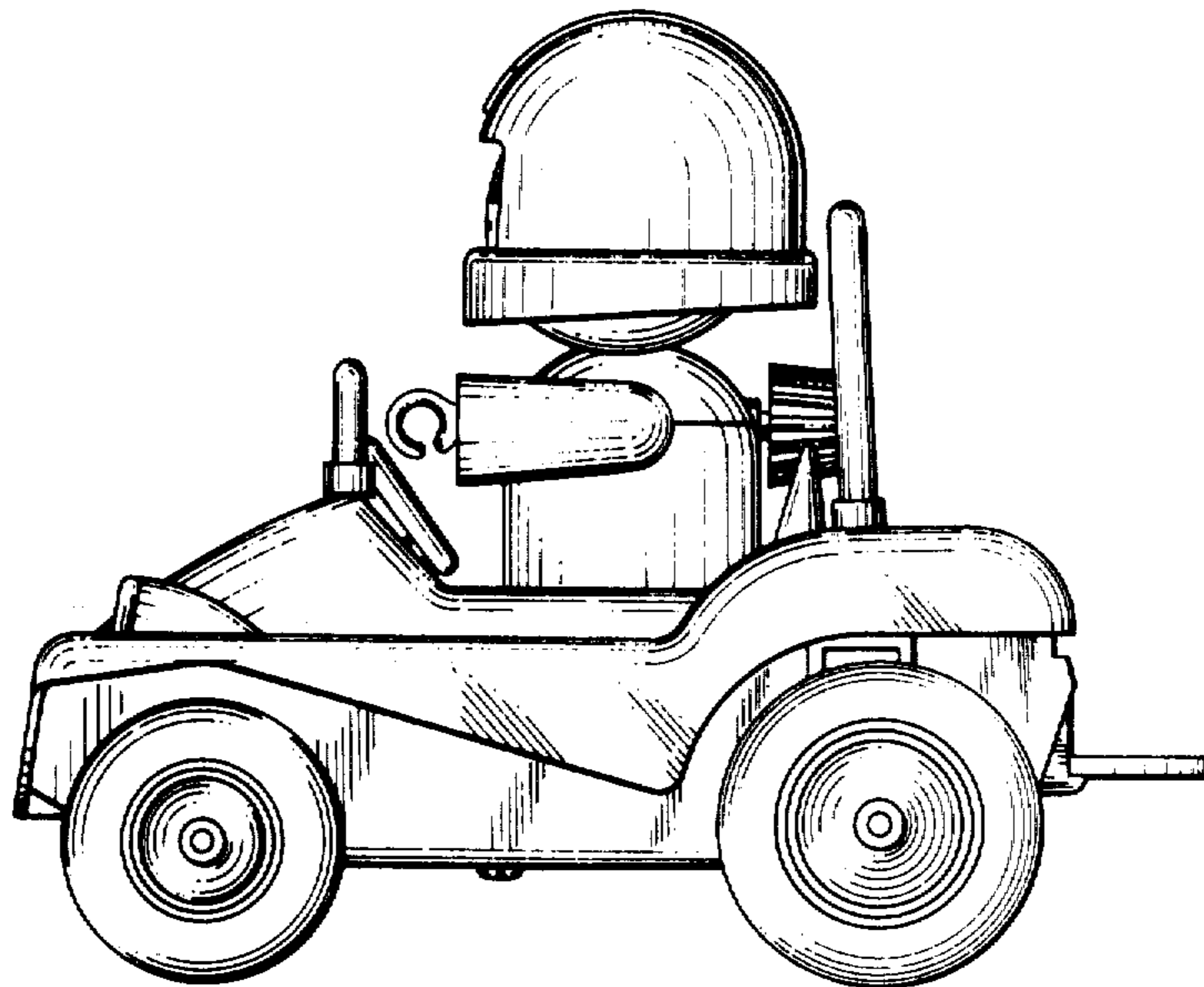

FIG. 1

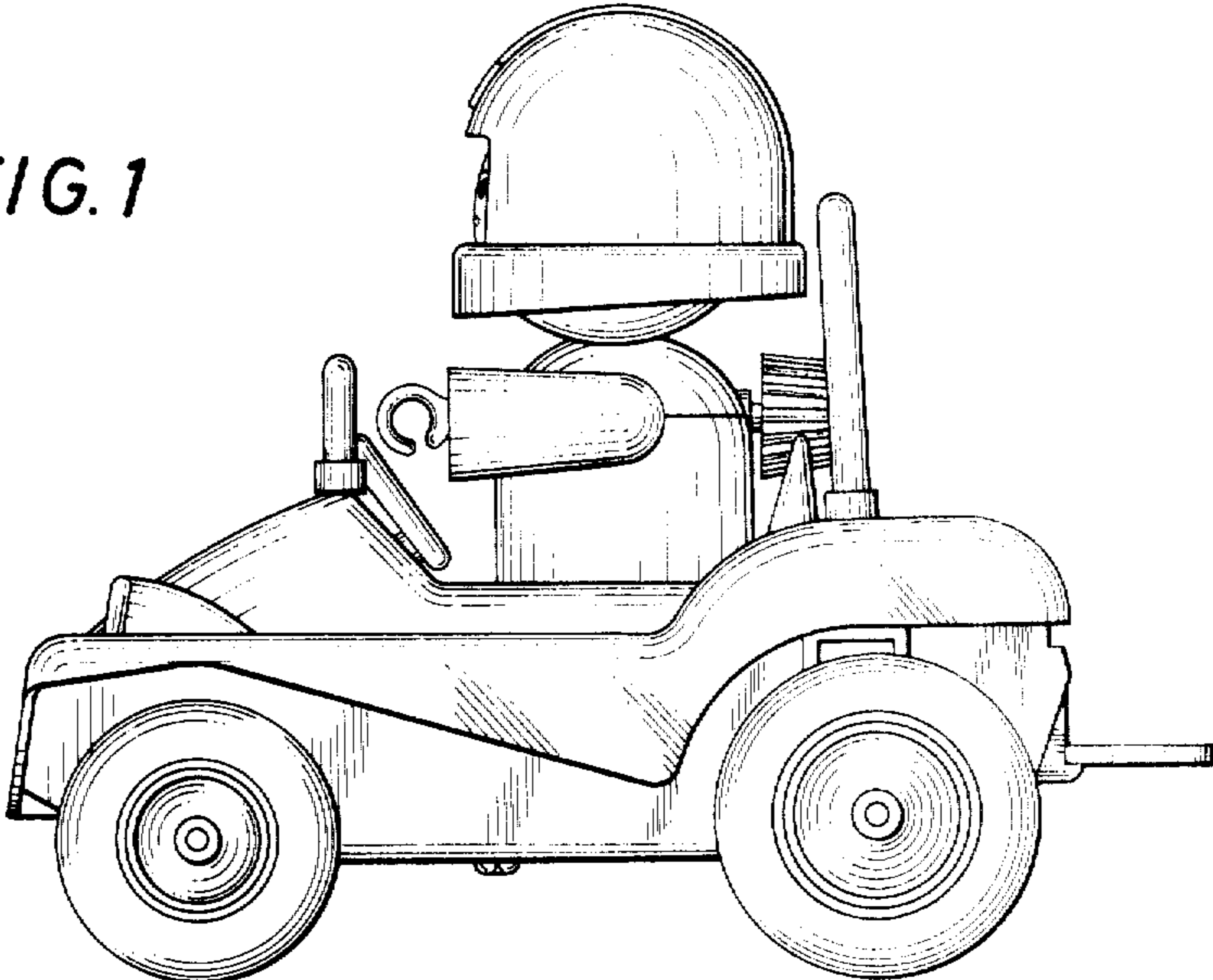

FIG. 2

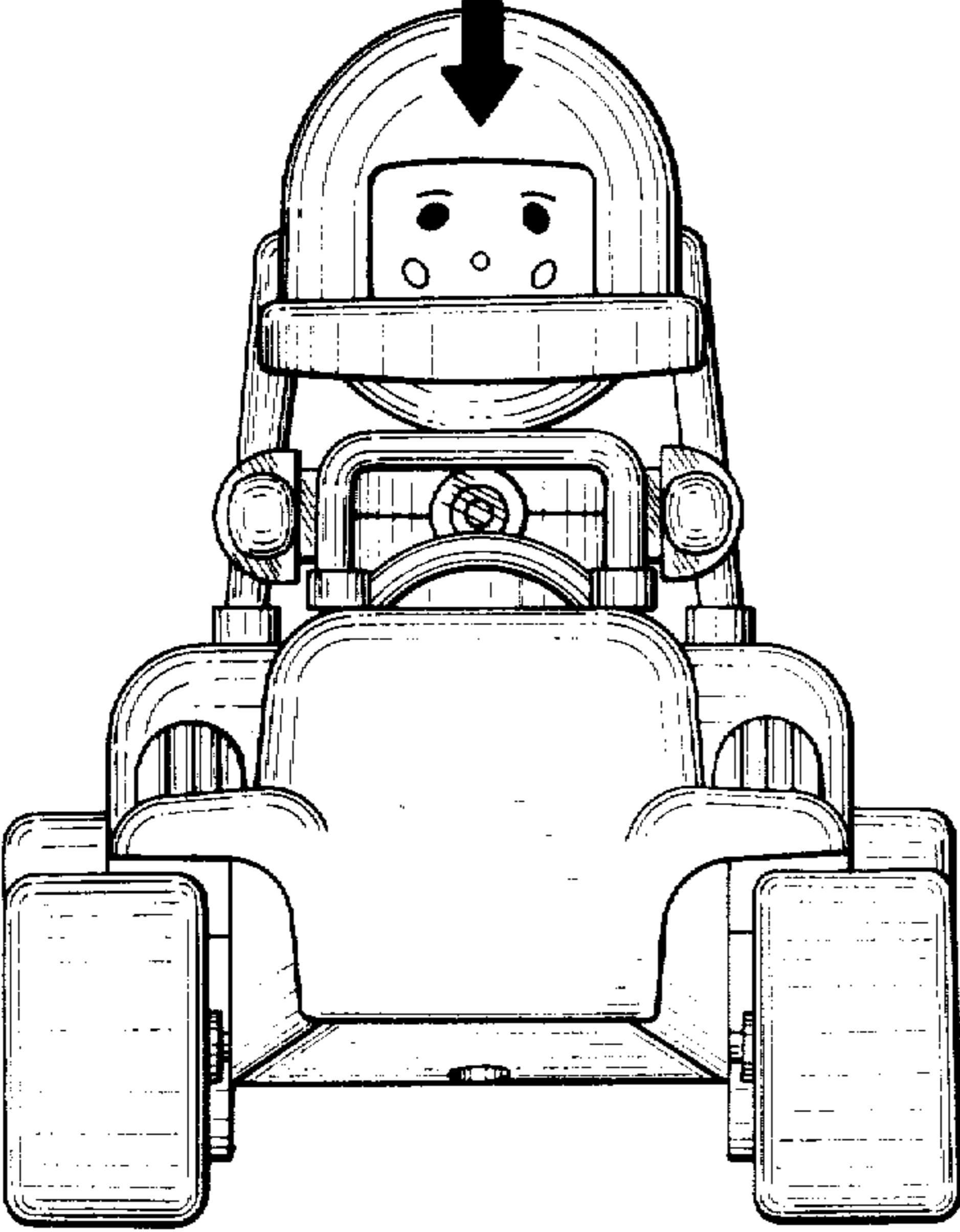

FIG. 3

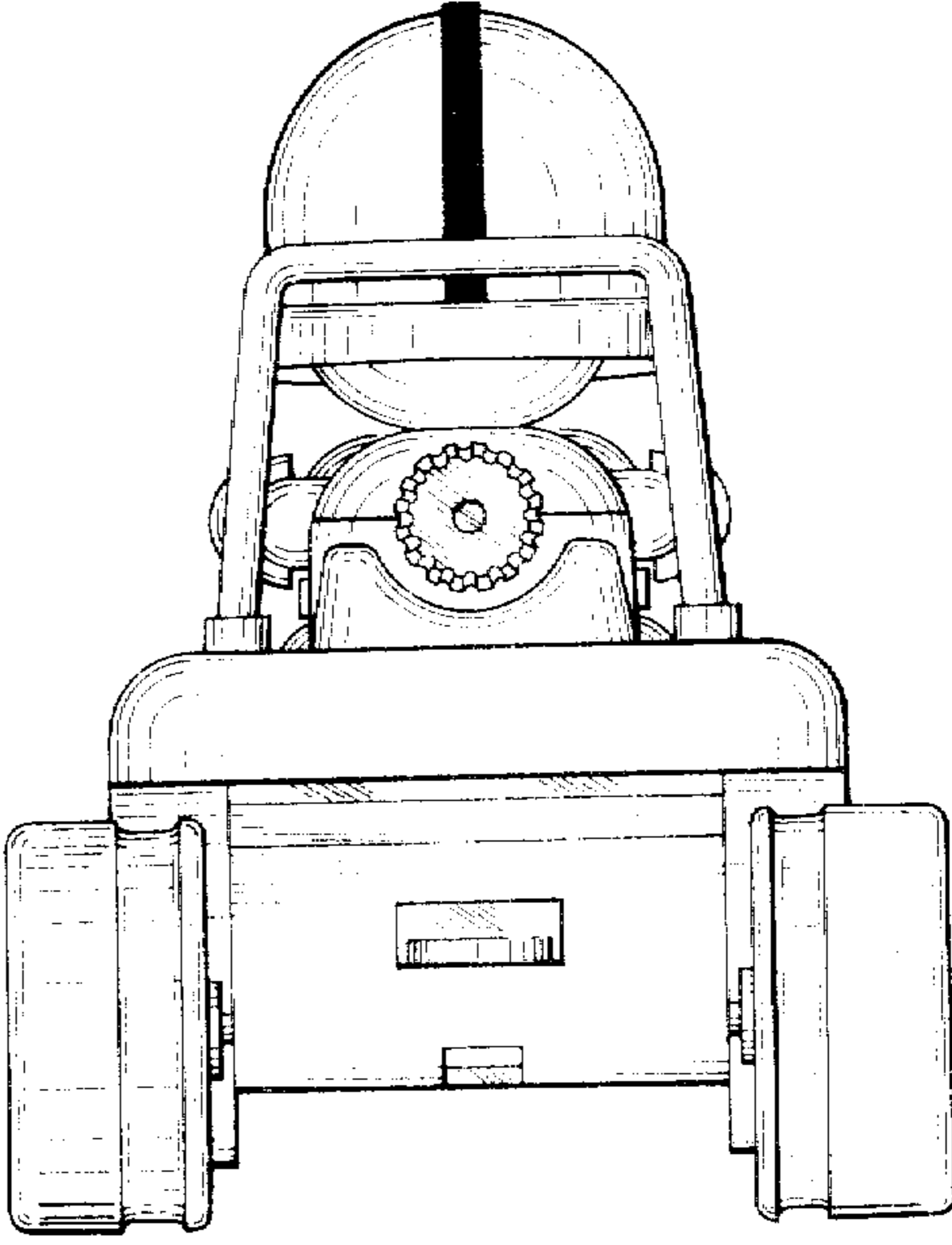

FIG. 4

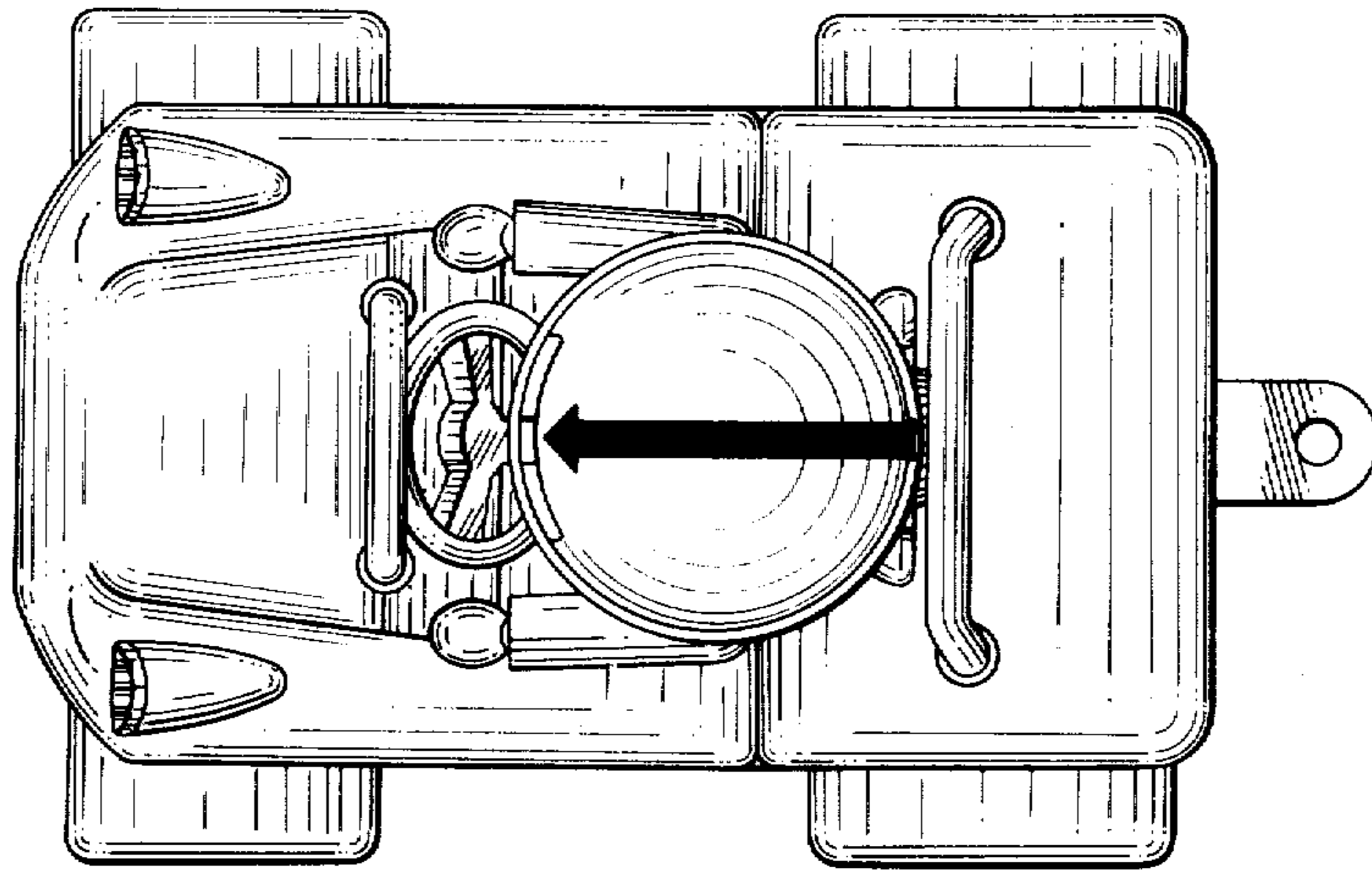

FIG. 5

