

[54] TAXI VEHICLE

[76] Inventor: Arthur R. Hutt, 707 Pluma Dr., Bellevue, Nebr. 68005

[\*\*] Term: 3½ Years

[21] Appl. No.: 17,019

[22] Filed: Mar. 2, 1979

[51] Int. Cl. .... D12-08

[52] U.S. Cl. .... D12/99

[58] Field of Search ..... D12/90, 99; D21/71, D21/76, 78, 79, 134, 128, 136, 140; 46/201, 202, 222, 111, 101, 209, 95, 17

[56] References Cited

U.S. PATENT DOCUMENTS

- D. 150,101 6/1948 Wallace ..... D12/99
- 2,982,578 5/1961 Lowe ..... D12/99
- 3,844,062 10/1974 Daugirdas ..... D21/140
- 4,156,986 6/1979 Kupperman et al. .... 46/201

FOREIGN PATENT DOCUMENTS

- 295110 4/1954 France ..... 46/201

OTHER PUBLICATIONS

Electrical World, 11-1973, p. 116, Vehicle at lower right corner of page.

Design, 7-1976, pp. 42 & 43, Vehicle.

Design, 6-1976, p. 330, GKN Vehicle.

Primary Examiner—Charles A. Rademaker

Attorney, Agent, or Firm—Henderson & Sturm

[57] CLAIM

The ornamental design for a taxi vehicle, substantially as shown and described.

DESCRIPTION

FIG. 1 is a front perspective view of a taxi vehicle showing my new design;

FIG. 2 is a left side elevational view thereof, the side opposite being substantially a mirror image;

FIG. 3 is a front elevational view thereof;

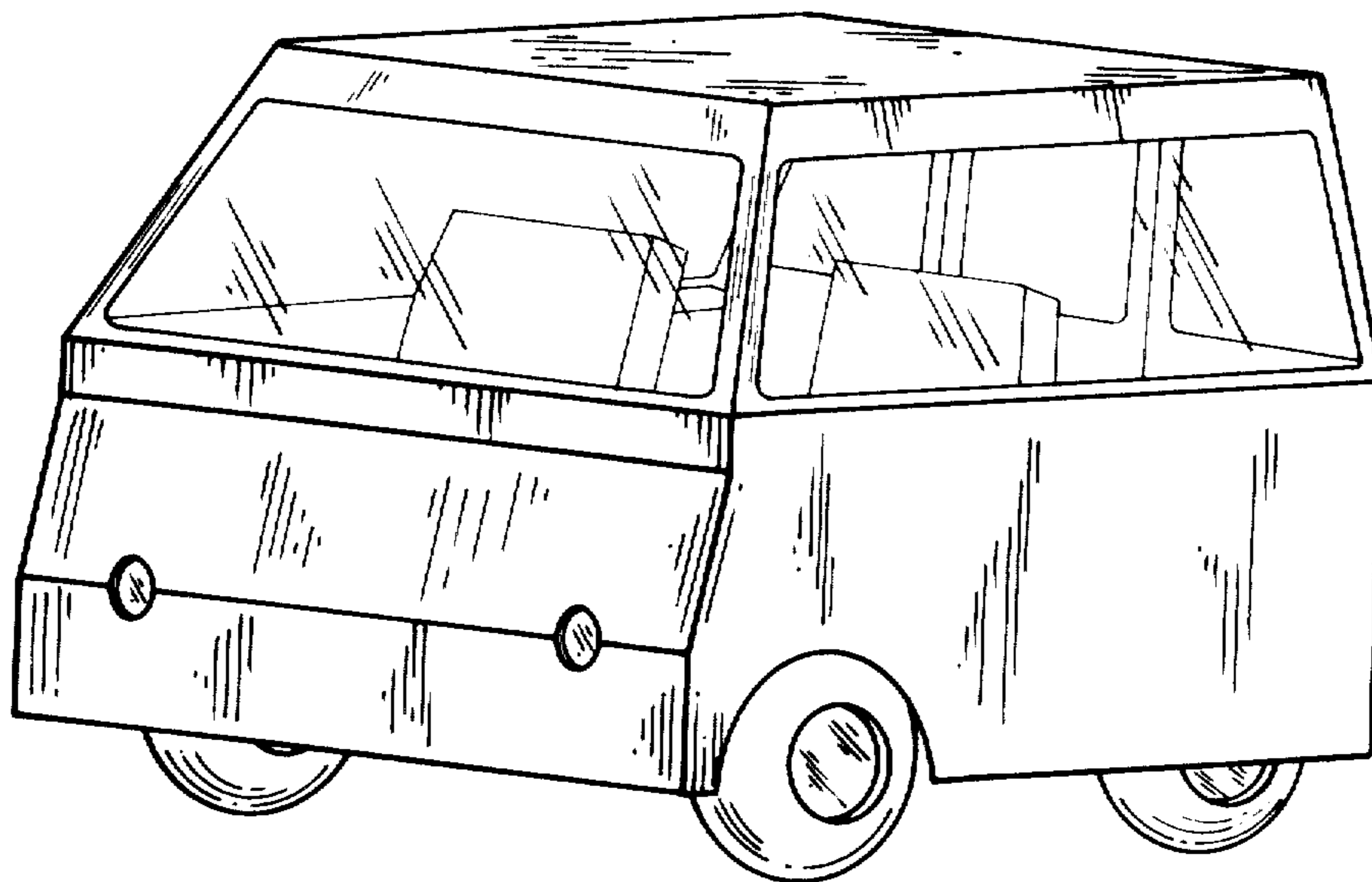
FIG. 4 is a rear elevational view thereof;

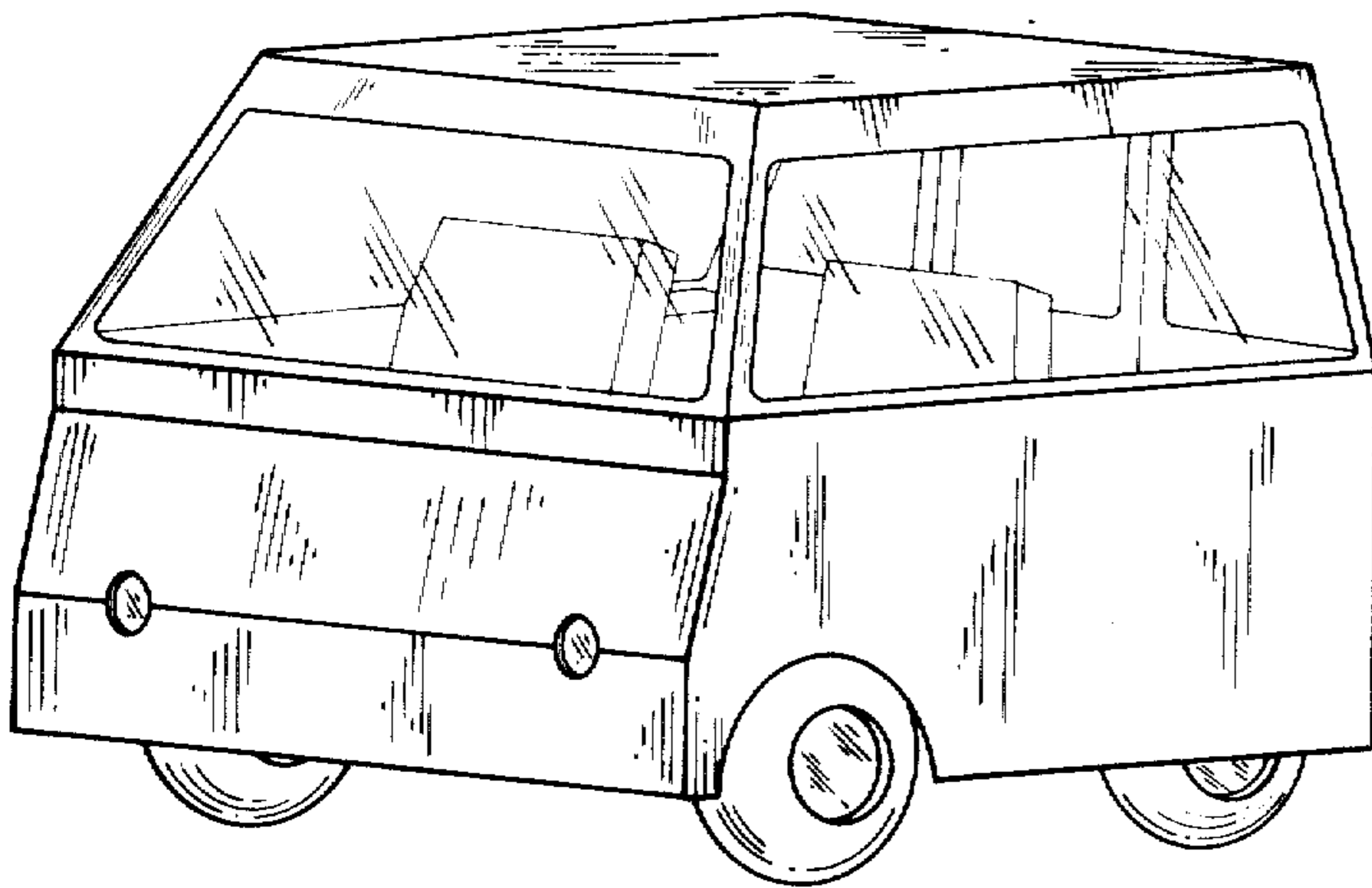
FIG. 5 is a top plan view thereof;

FIG. 6 is a bottom plan view thereof;

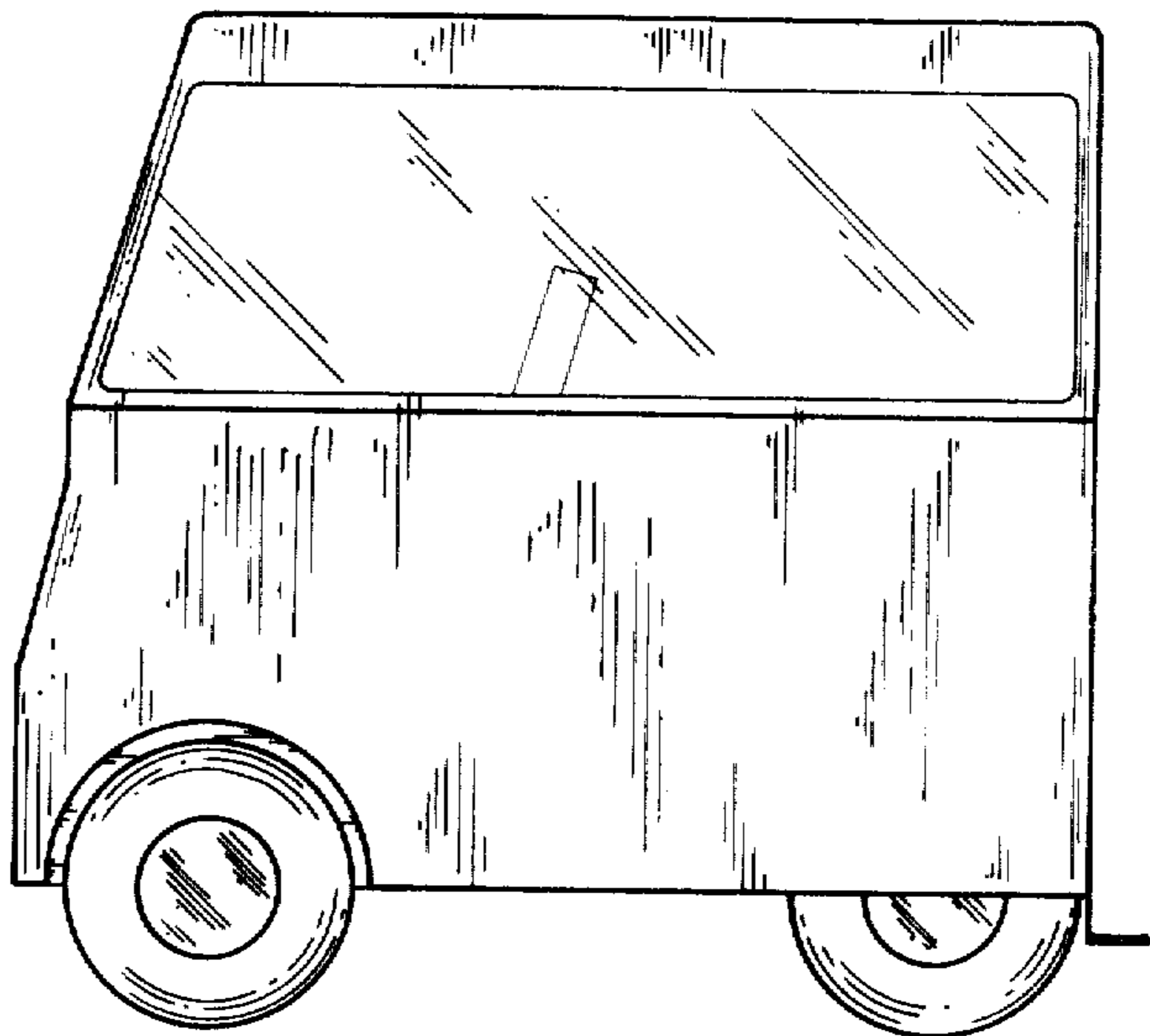
FIG. 7 is a cross sectional view thereof taken along lines 7-7 in FIG. 3; and

FIG. 8 is a cross sectional view thereof taken along lines 8-8 in FIG. 5.

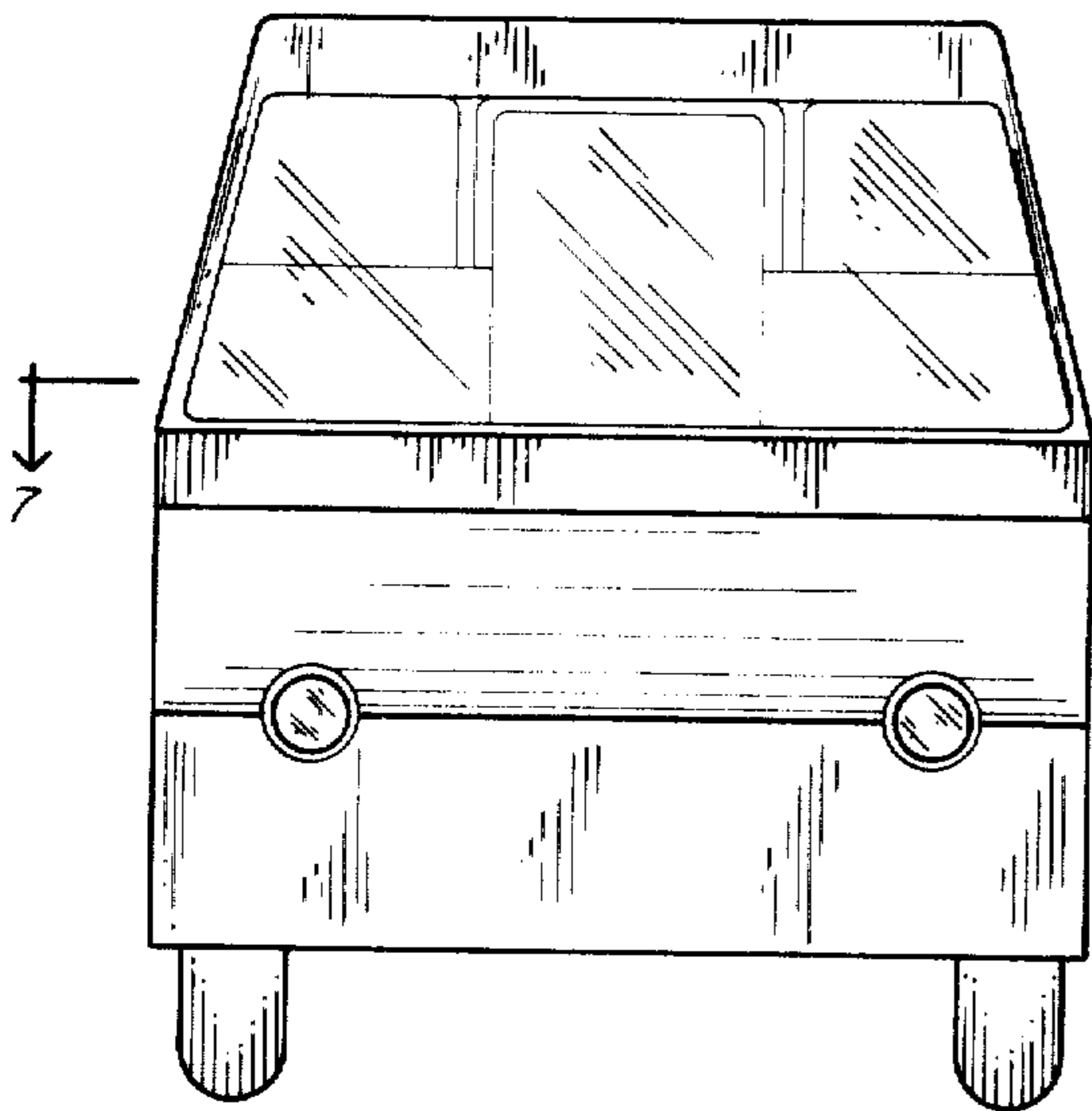




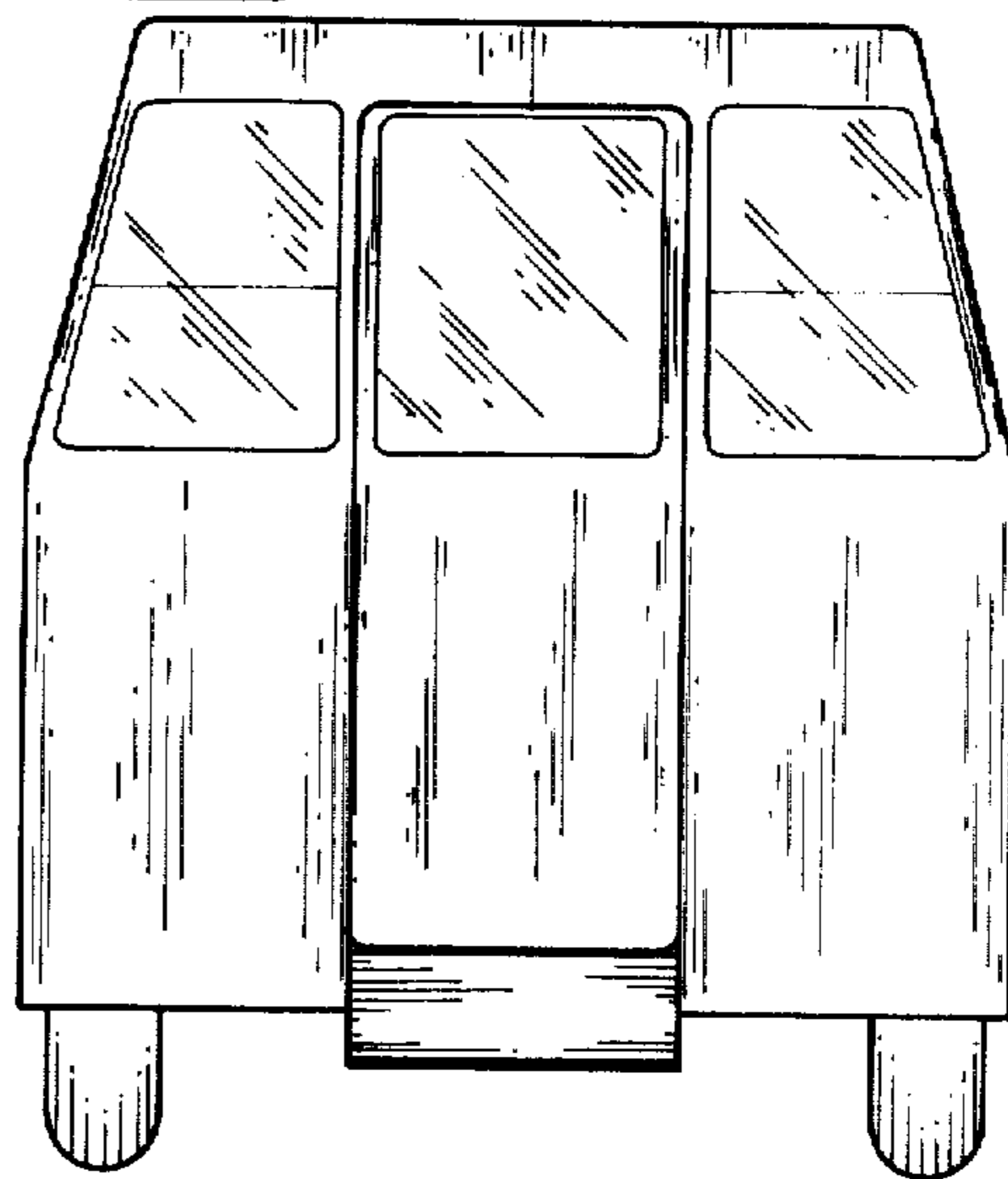
*Fig. 1*



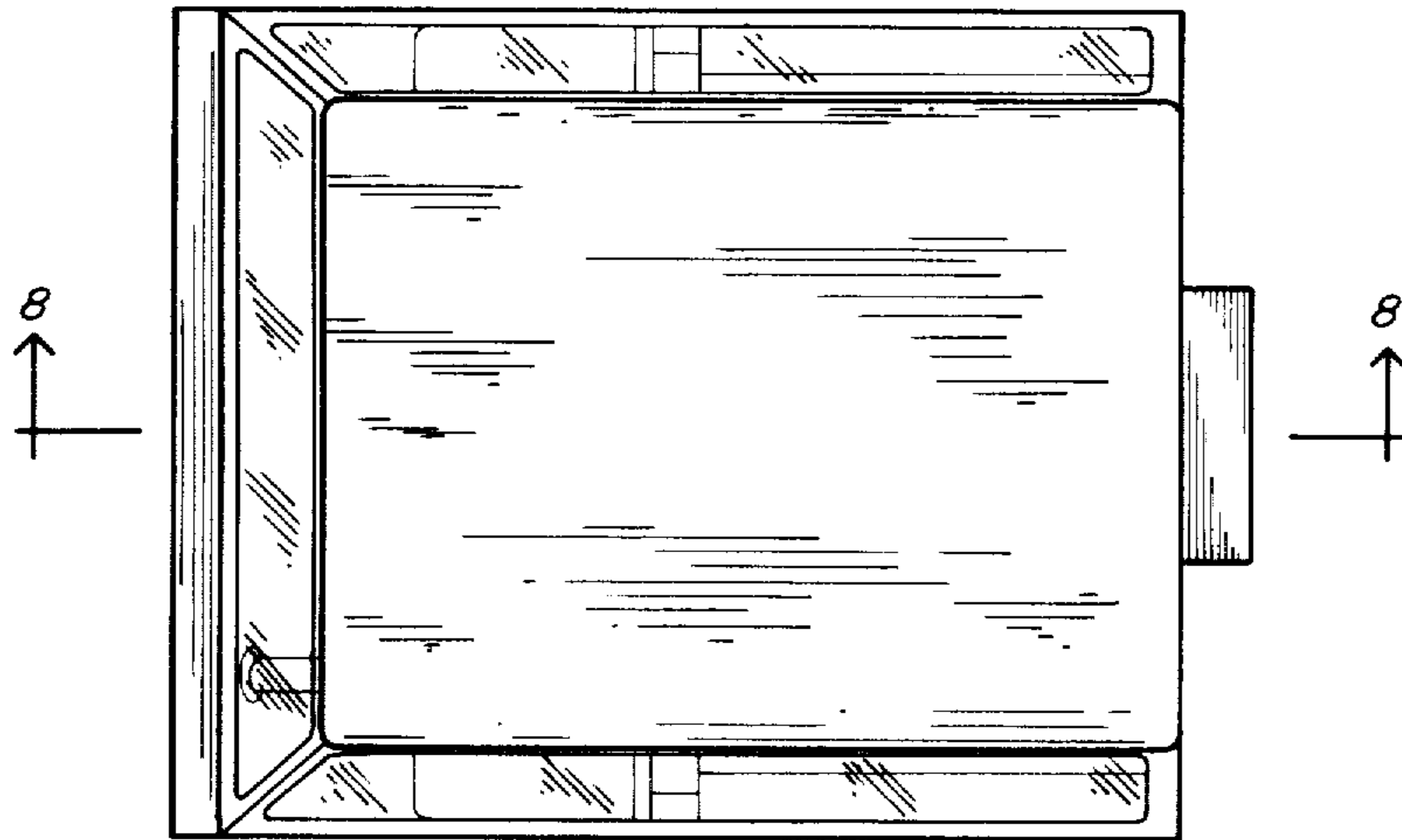
*Fig. 2*



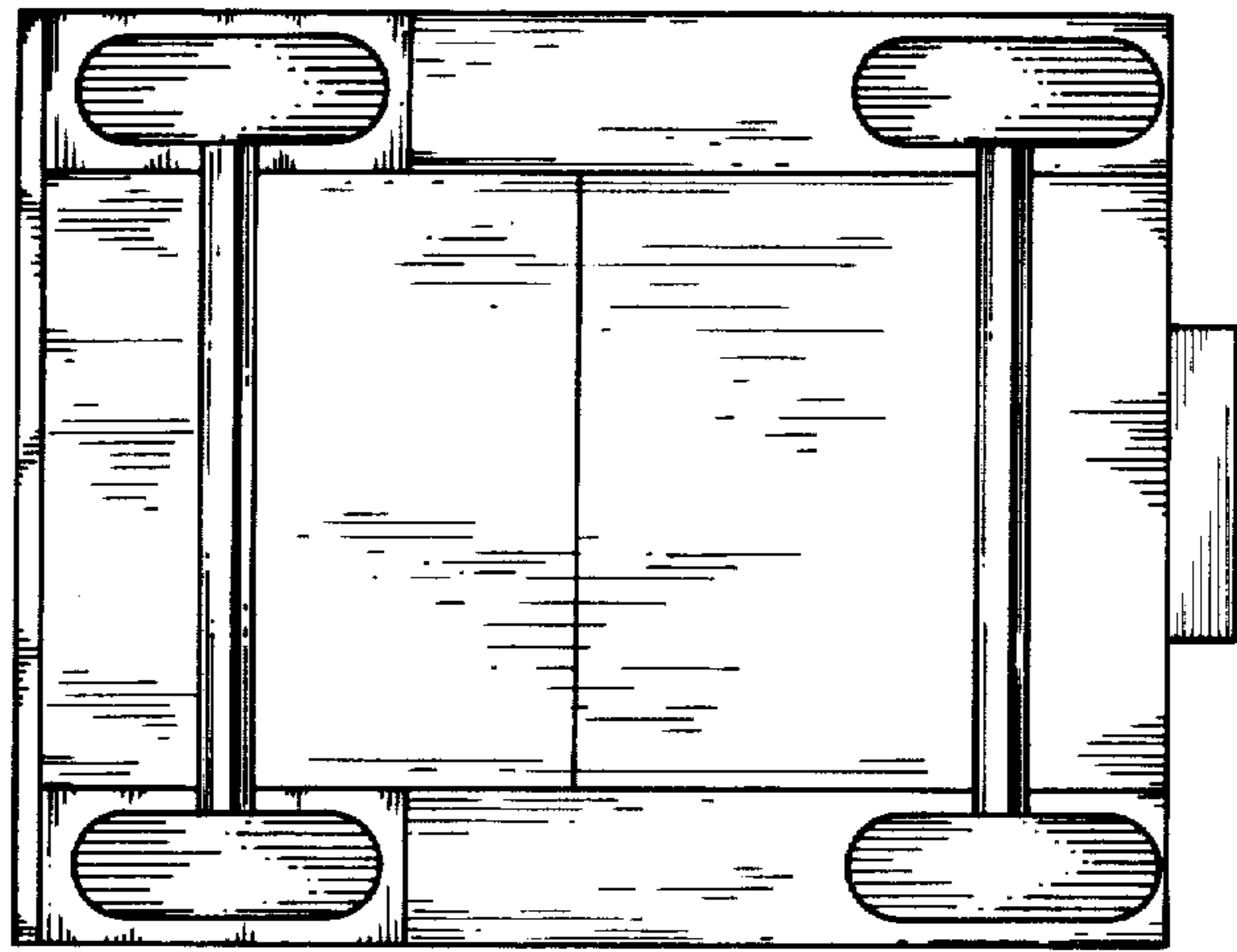
*Fig. 3*



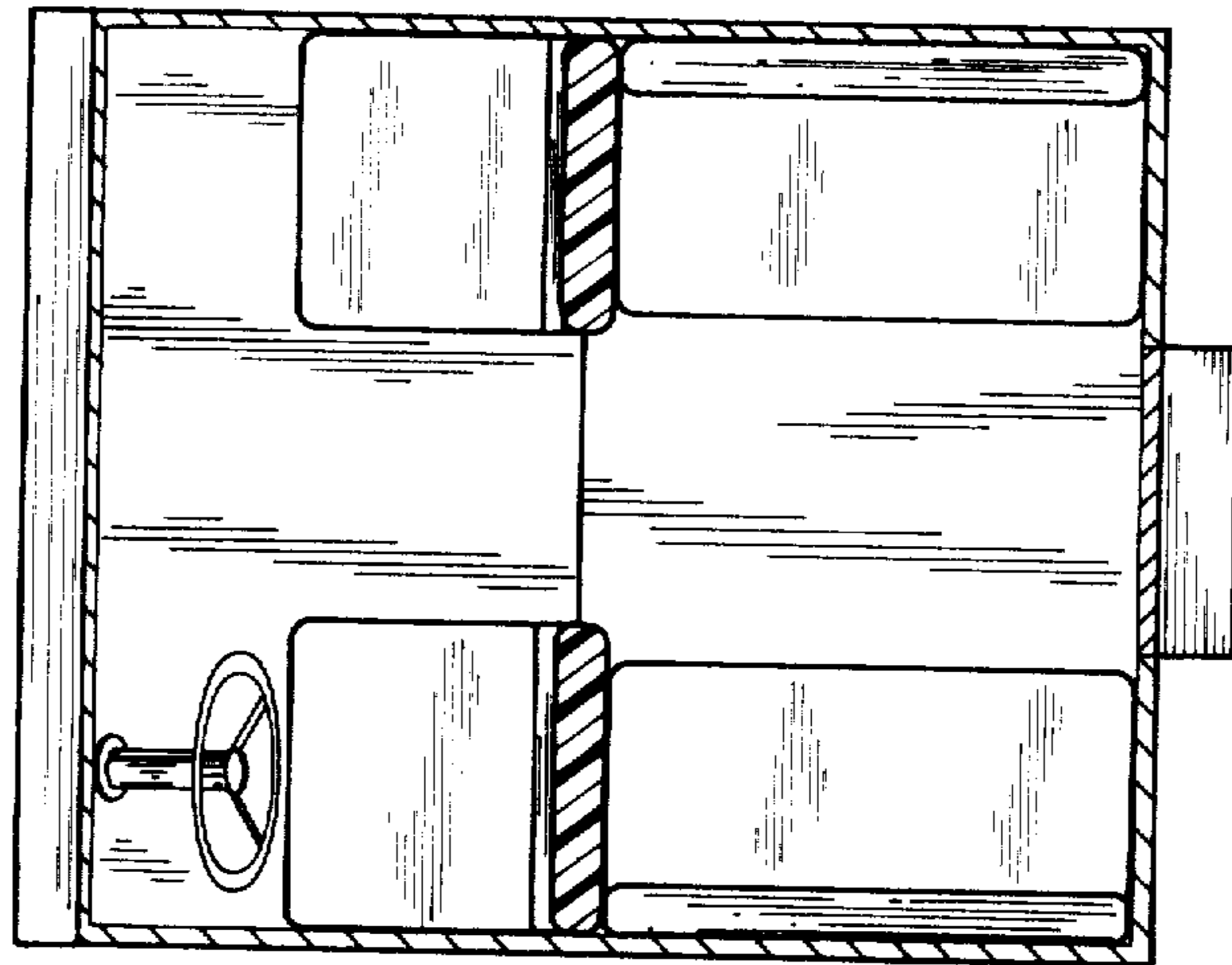
*Fig. 4*



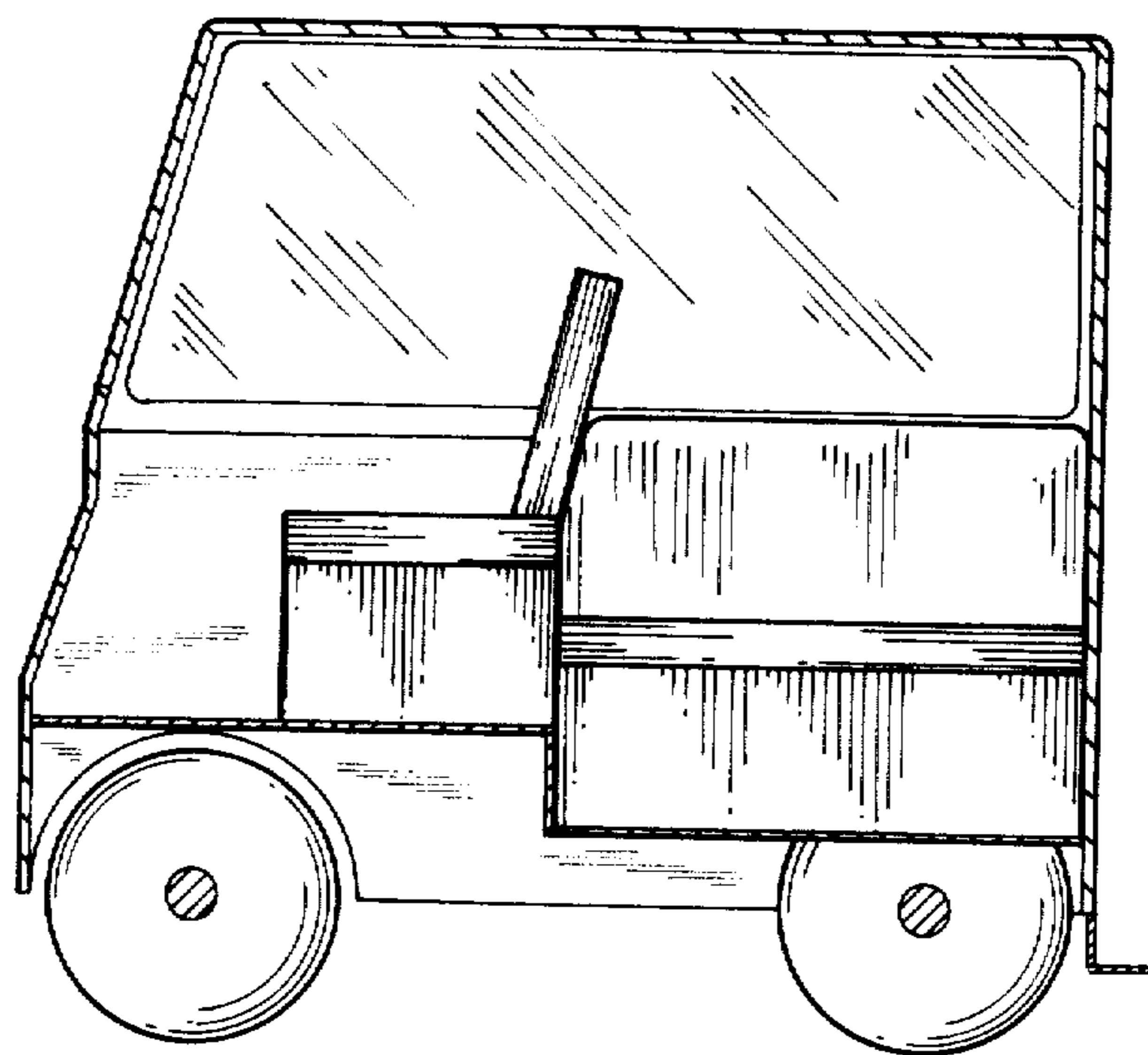
*FIG. 5*



*FIG. 6*



*Fig. 7*



*Fig. 8*