

[54] BLOOD PRESSURE MEDICAL MEASUREMENT APPARATUS

3,905,354 9/1975 Lichowsky ..... 128/681  
4,162,674 7/1979 Klein ..... 128/680

[75] Inventor: Stacey Duckat, Miraleste, Calif.

Primary Examiner—Bernard Ansher  
Attorney, Agent, or Firm—Fulwider, Patton, Rieber,  
Lee & Utecht

[73] Assignee: National Blood Pressure Services, Inc., Irvine, Calif.

[\*\*] Term: 14 Years

[57] CLAIM

[21] Appl. No.: 16,089

The ornamental design for a blood pressure medical measurement apparatus, substantially as shown and described.

[22] Filed: Feb. 28, 1979

DESCRIPTION

[51] Int. Cl. .... D24-01

[52] U.S. Cl. .... D24/1.1; D24/21

[58] Field of Search .... D24/21, 1.1, 17;  
128/680, 681, 682; D20/1

FIG. 1 is a perspective view of a blood pressure medical measurement apparatus, showing my new design;  
FIG. 2 is a side elevational view of one side of said apparatus;  
FIG. 3 is a top plan view of said apparatus;  
FIG. 4 is a rear elevational view of said apparatus;  
FIG. 5 is a front elevational view of said apparatus;  
FIG. 6 is a side elevational view of the side opposite that shown in FIG. 2 of said apparatus; and  
FIG. 7 is a bottom view of said apparatus.

[56] References Cited

U.S. PATENT DOCUMENTS

- D. 244,235 5/1977 Lichowsky ..... D24/21
- D. 250,896 1/1979 Huber ..... D24/21
- D. 254,629 4/1980 Yen ..... D24/1.1 X

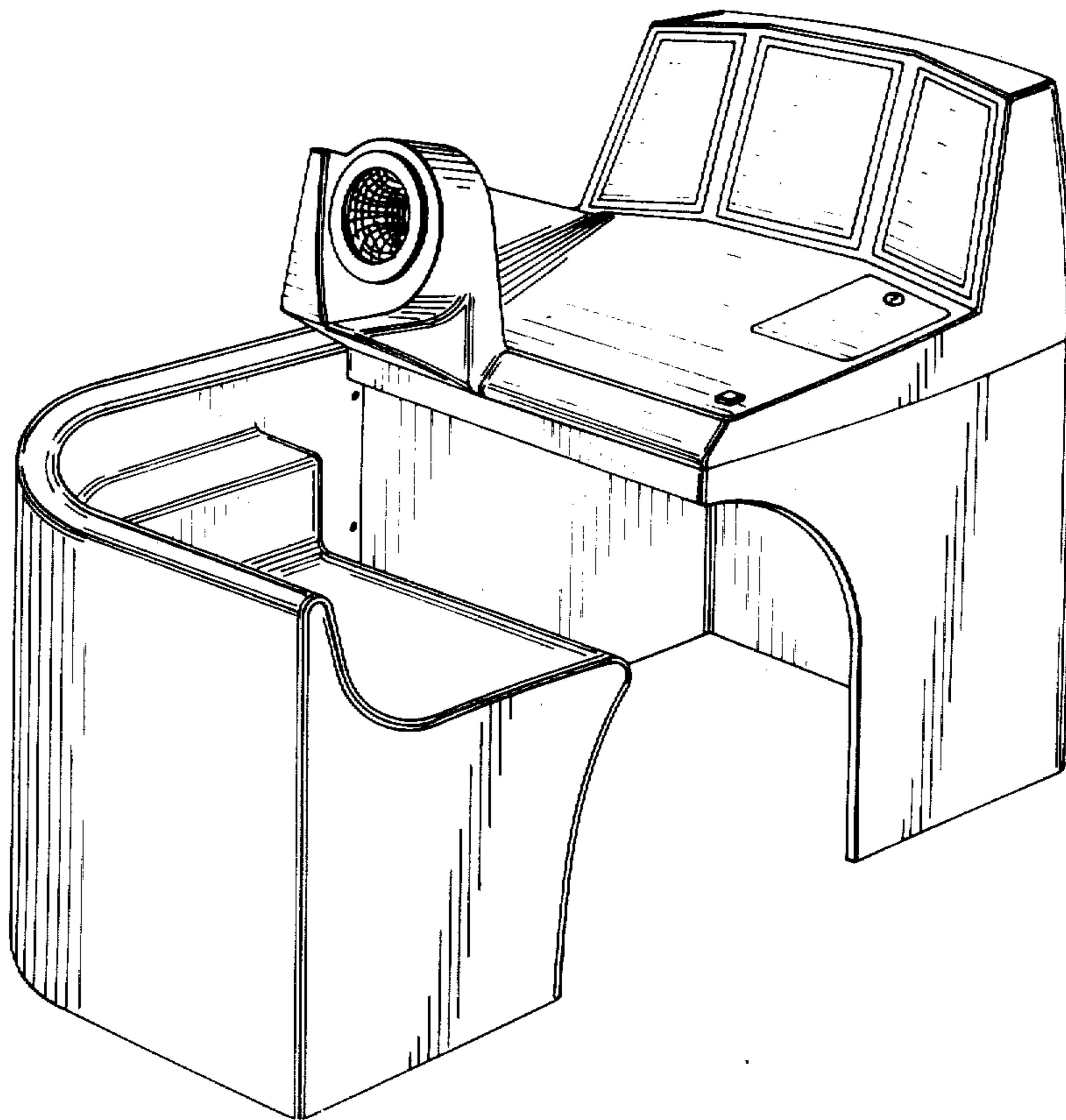

FIG. 1

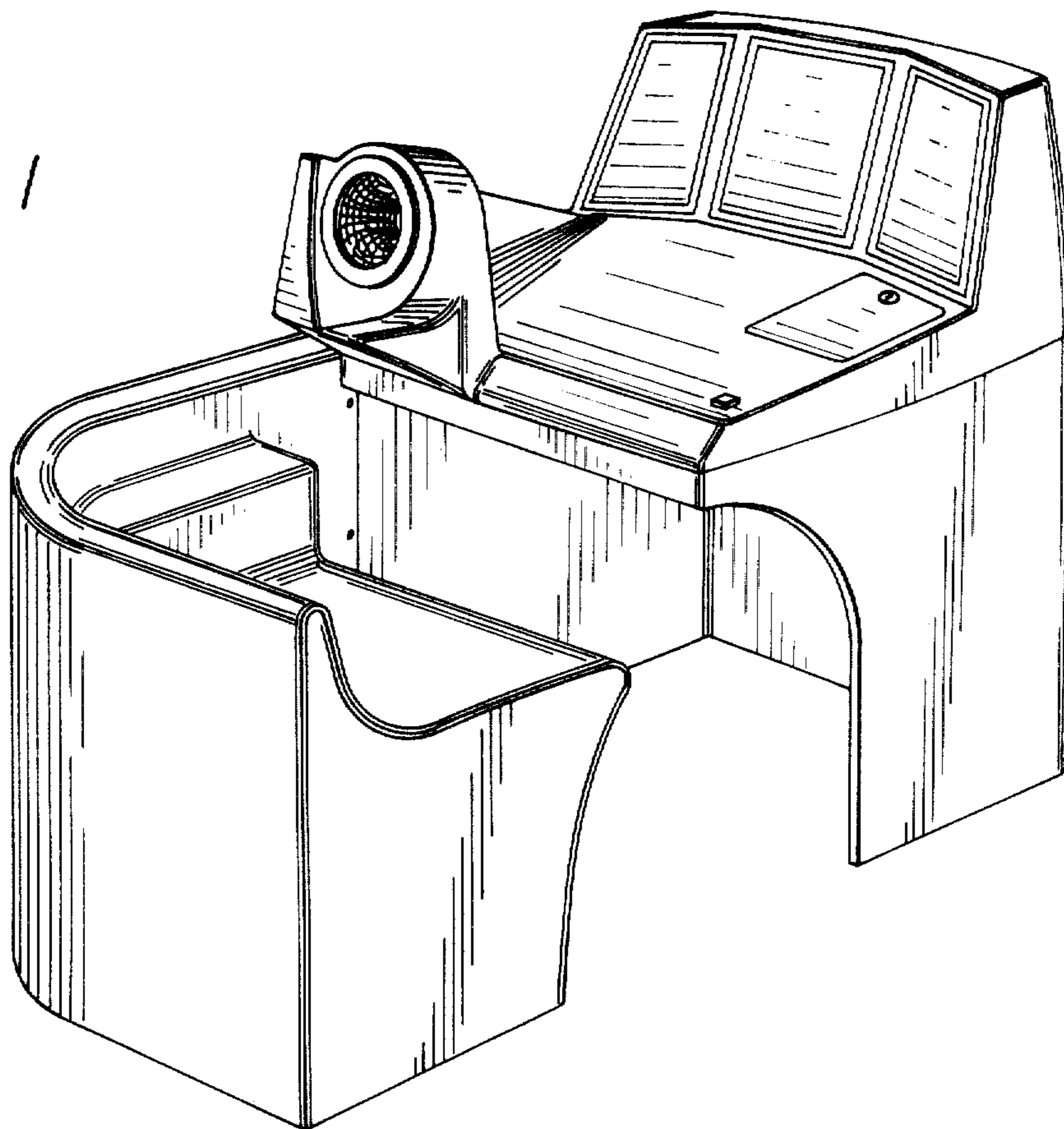

FIG. 2

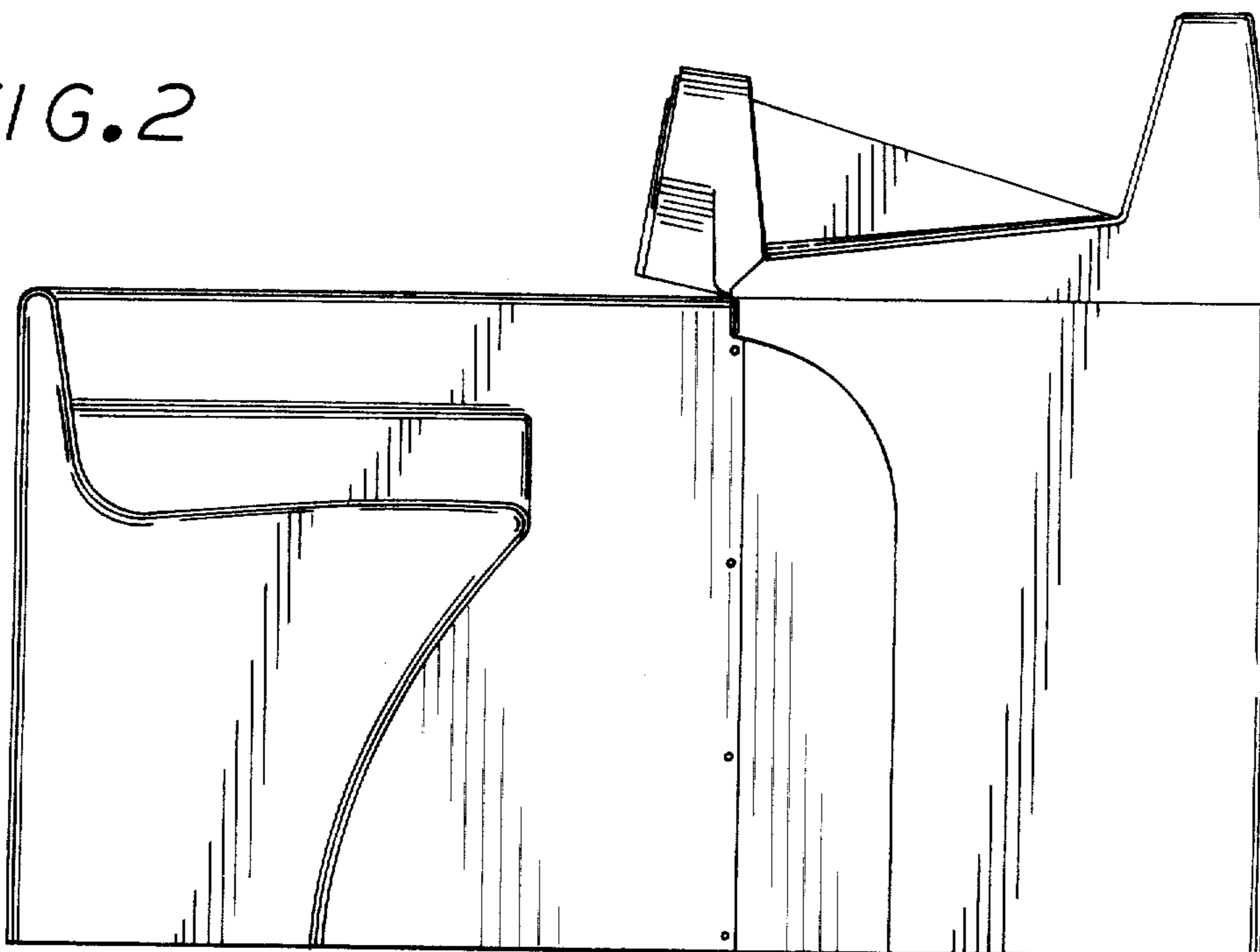

FIG. 3

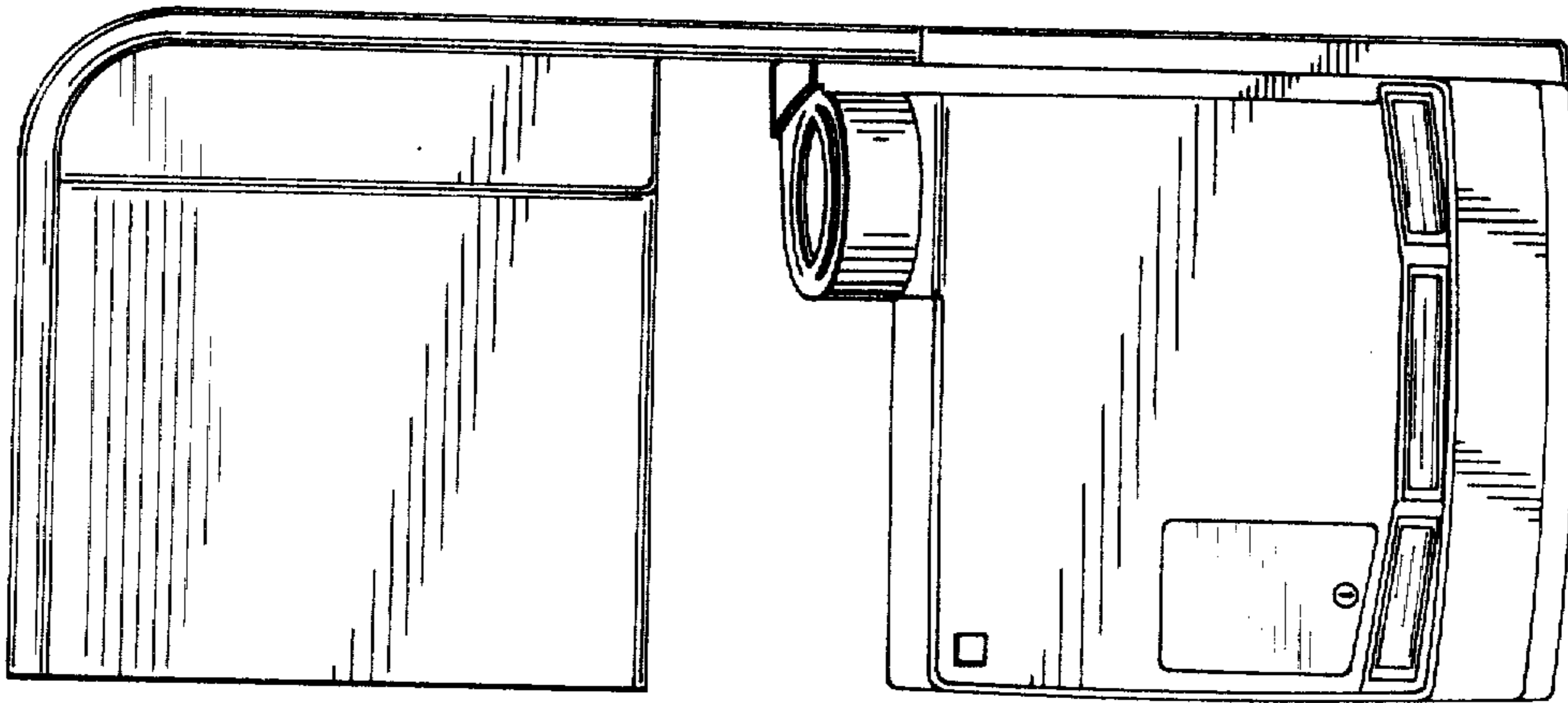

FIG. 4

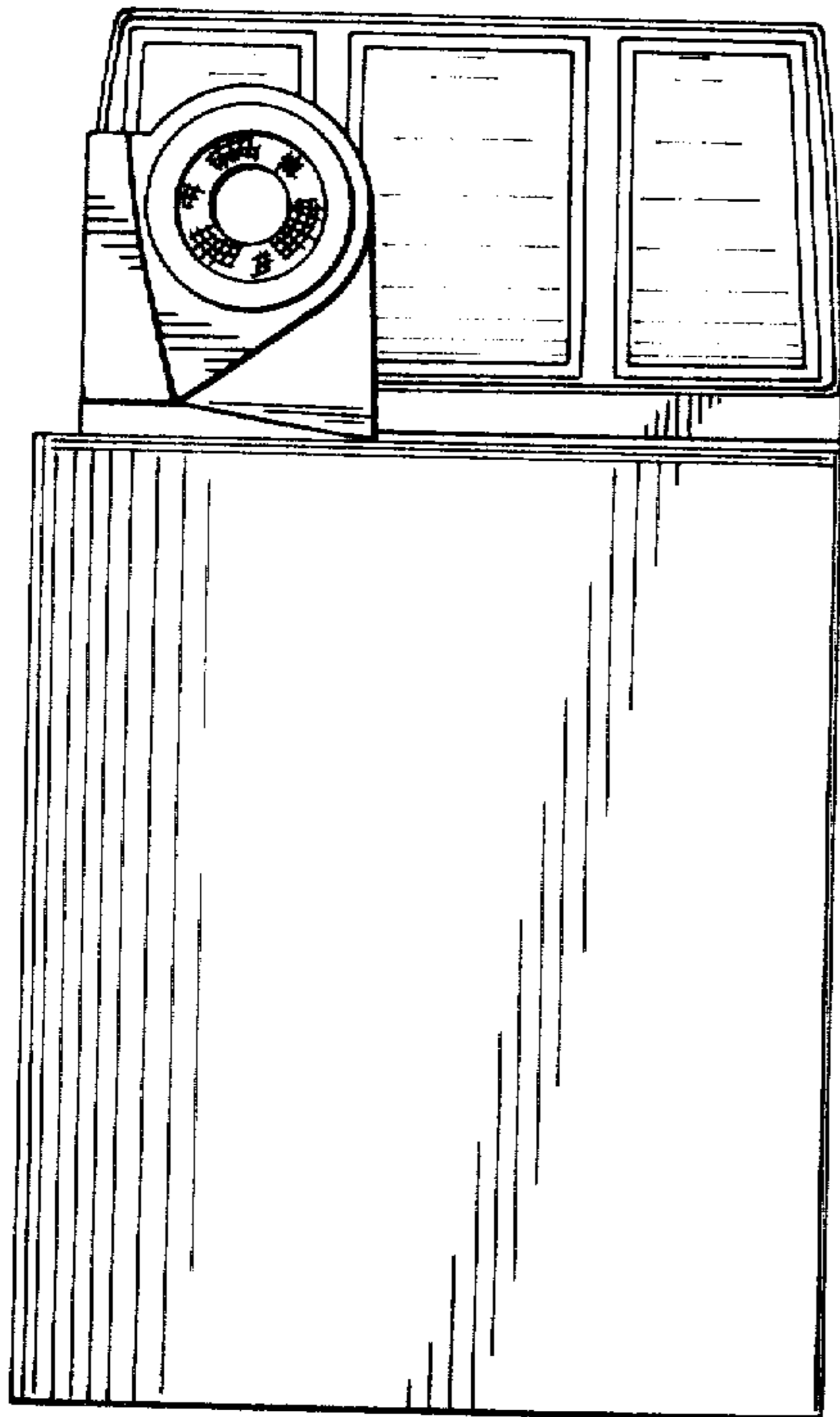

FIG. 5

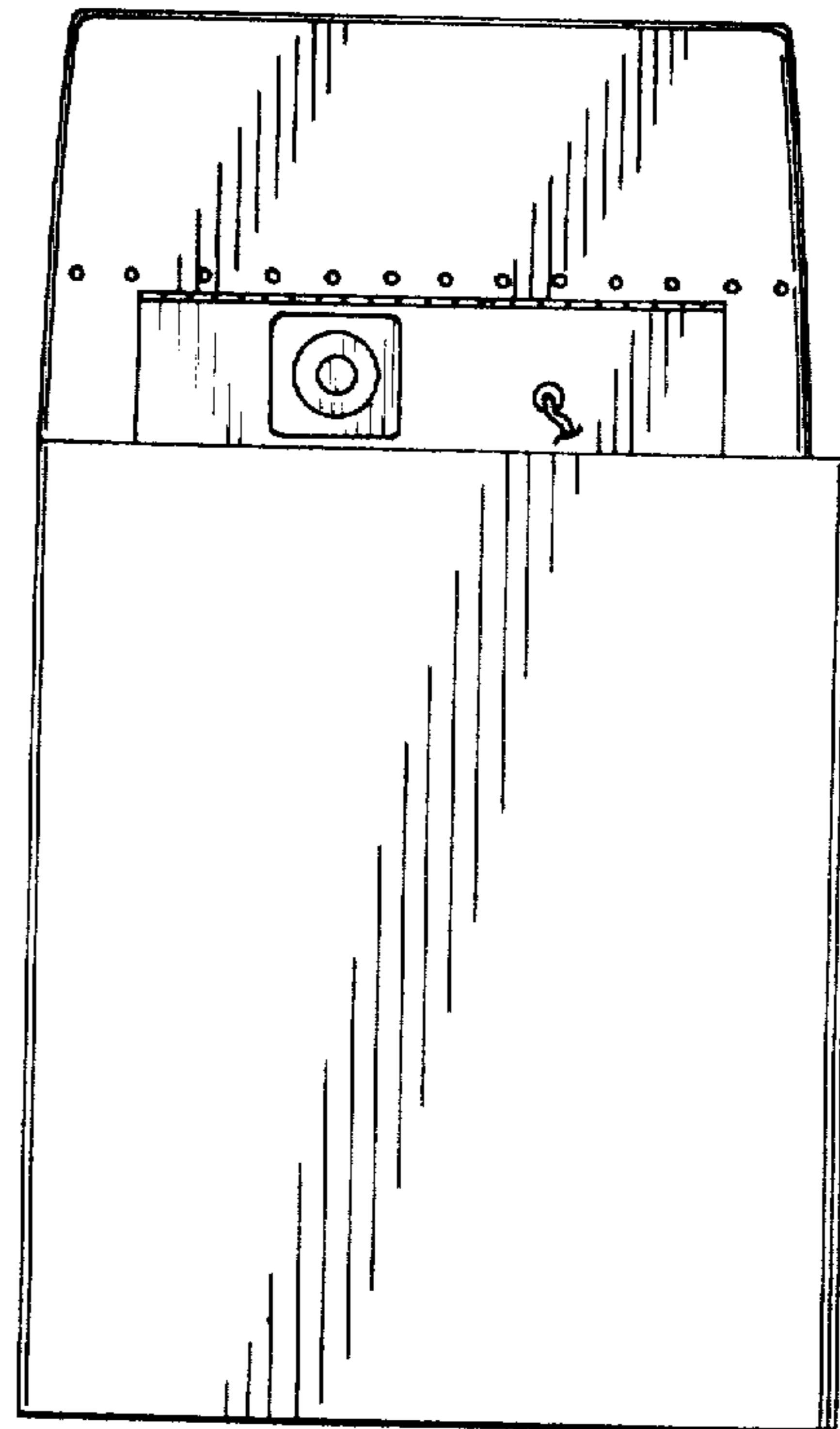

FIG. 6

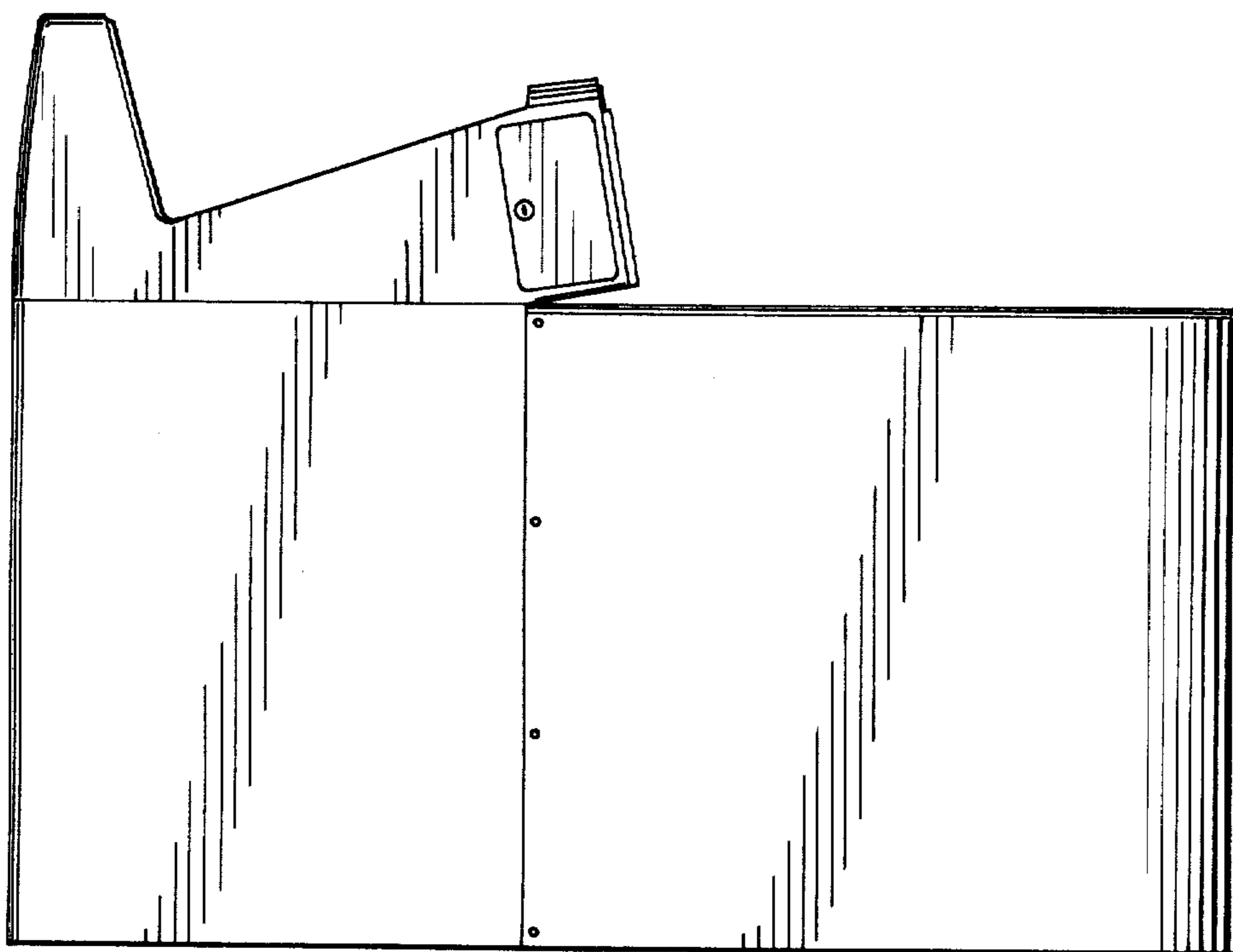

FIG. 7

