

[54] FIREPLACE GRATE AND BLOWER TUBE SURROUND ASSEMBLY WITH ELEVATED WATER HEATING HEAT EXCHANGER TUBES AND BAFFLE STRUCTURE

[75] Inventor: Byron D. Lane, Minot, N. Dak.

[73] Assignee: Firemaster Systems, Inc., Minot, N. Dak.

[**] Term: 14 Years

[21] Appl. No.: 88,283

[22] Filed: Oct. 25, 1979

[51] Int. Cl. D23-03

[52] U.S. Cl. D23/95; D7/207; D23/96

[58] Field of Search D23/92-97, D23/127, 135, 136; D7/206, 207; 126/120, 121, 123, 126, 134, 135, 136, 163, 164, 165

[56] References Cited

U.S. PATENT DOCUMENTS

- D. 242,542 11/1976 Betenbaugh, Jr. D23/96
- D. 254,388 3/1980 Chesnut et al. D23/96 X

4,161,168 7/1979 Cagle 126/164

Primary Examiner—Catherine E. Kemper
Attorney, Agent, or Firm—Mason, Fenwick & Lawrence

[57] CLAIM

The ornamental design for a fireplace grate and blower tube surround assembly with elevated water heating heat exchanger tubes and baffle structure, as shown and described.

DESCRIPTION

FIG. 1 is a front perspective view of the fireplace grate and blower tube surround assembly with elevated water heating heat exchanger tubes and baffle structure, viewed from above and to the front of the assembly, illustrating my new design;

FIG. 2 is a rear elevation view thereof, viewed from above and to the rear thereof;

FIG. 3 is an end elevation view thereof, viewed from the right of FIG. 4, the opposite end elevation being substantially the mirror image thereof;

FIG. 4 is a front elevation view thereof, the rear elevation being substantially the mirror image thereof; and

FIG. 5 is a horizontal section view, taken along the line 5-5 of FIG. 3.

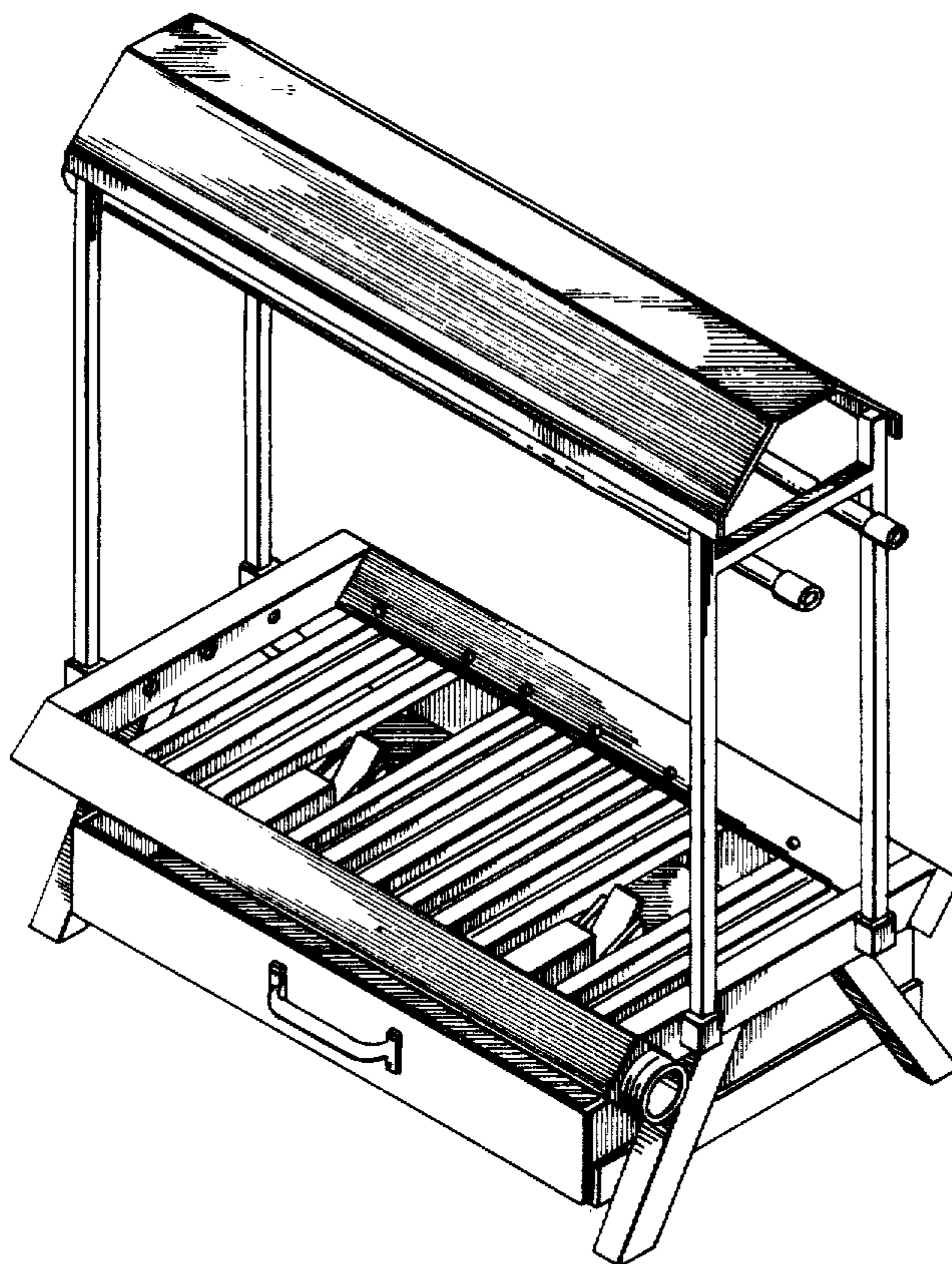

Fig-2

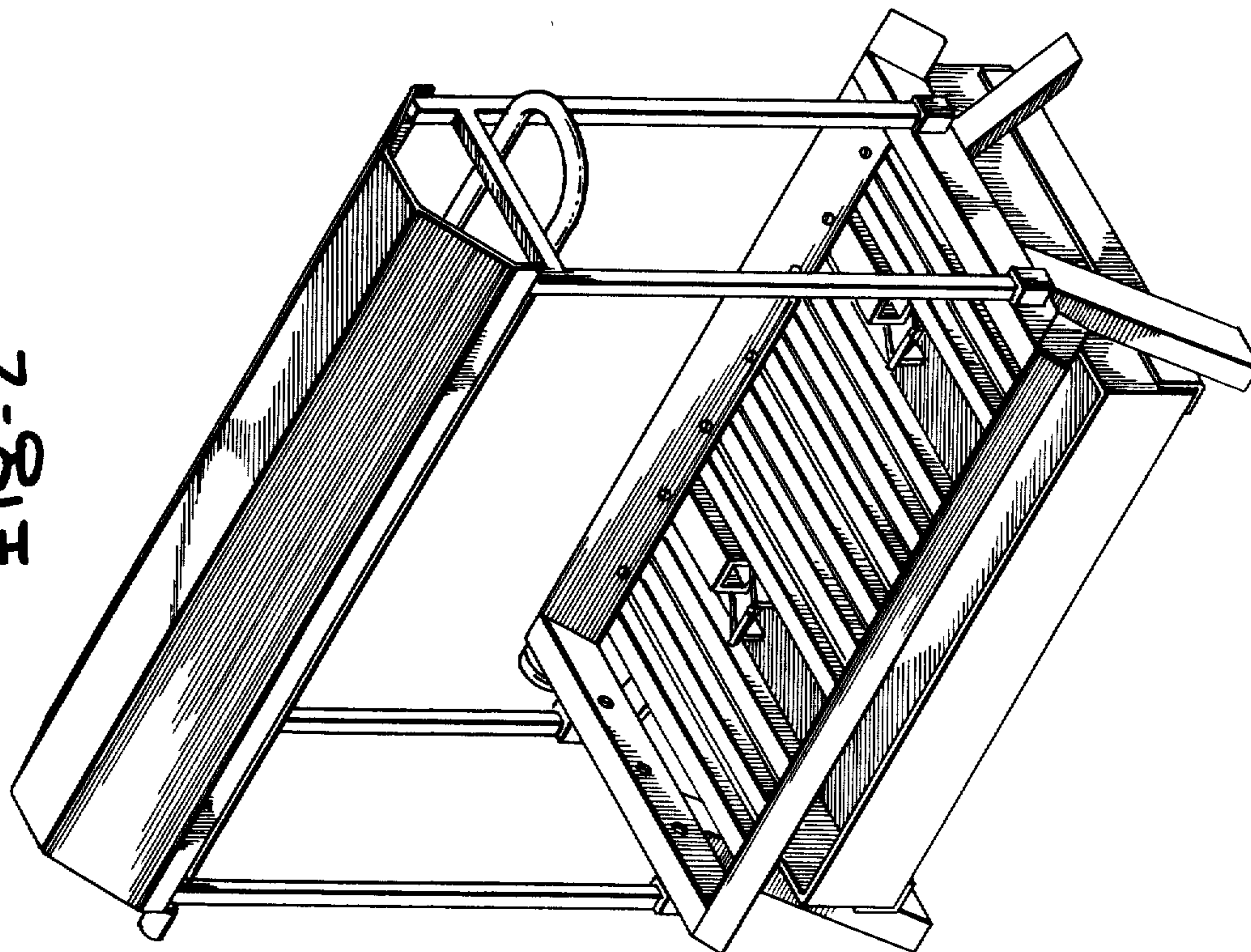

Fig-1

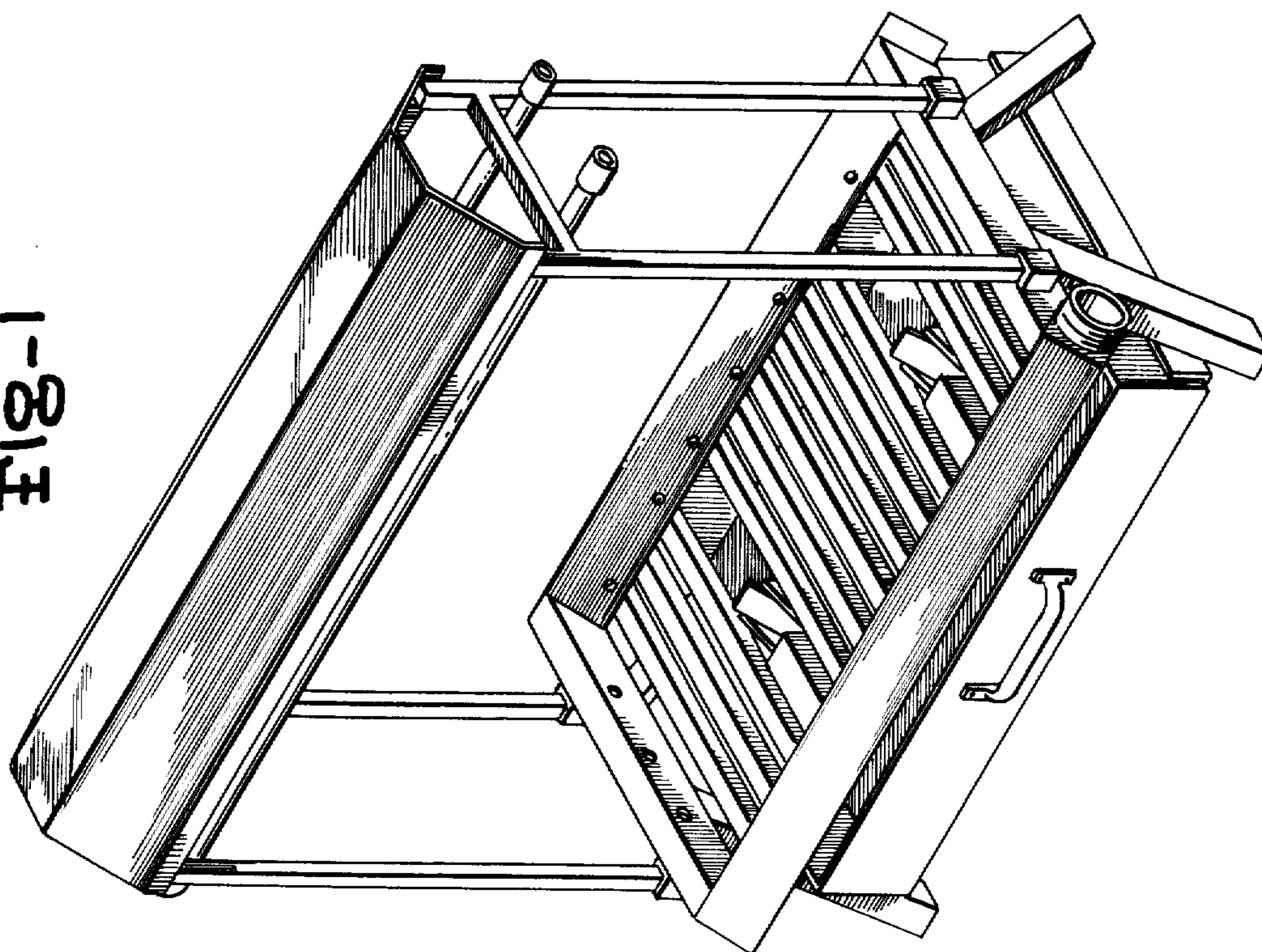

FIG. 3

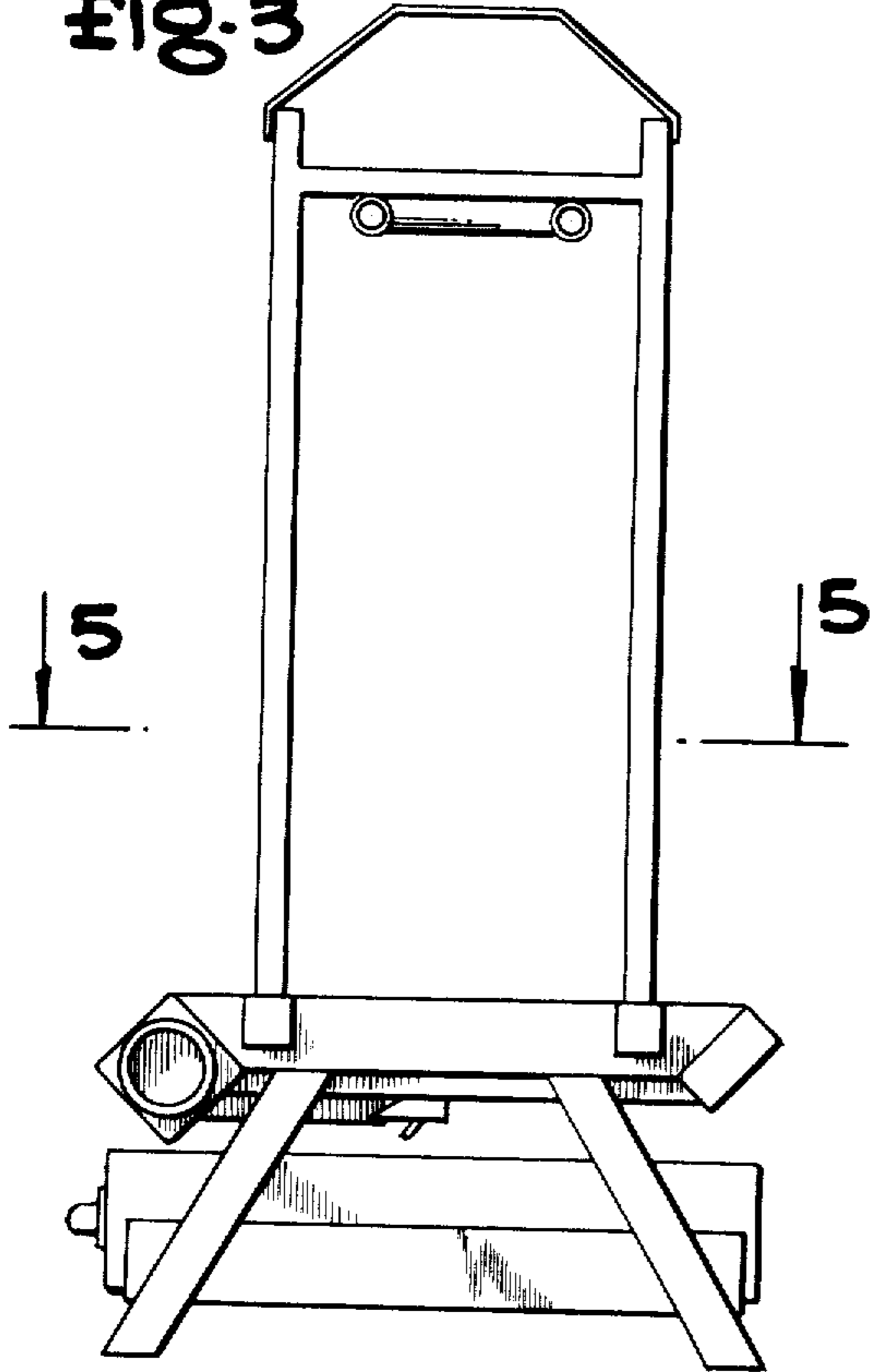

FIG. 5

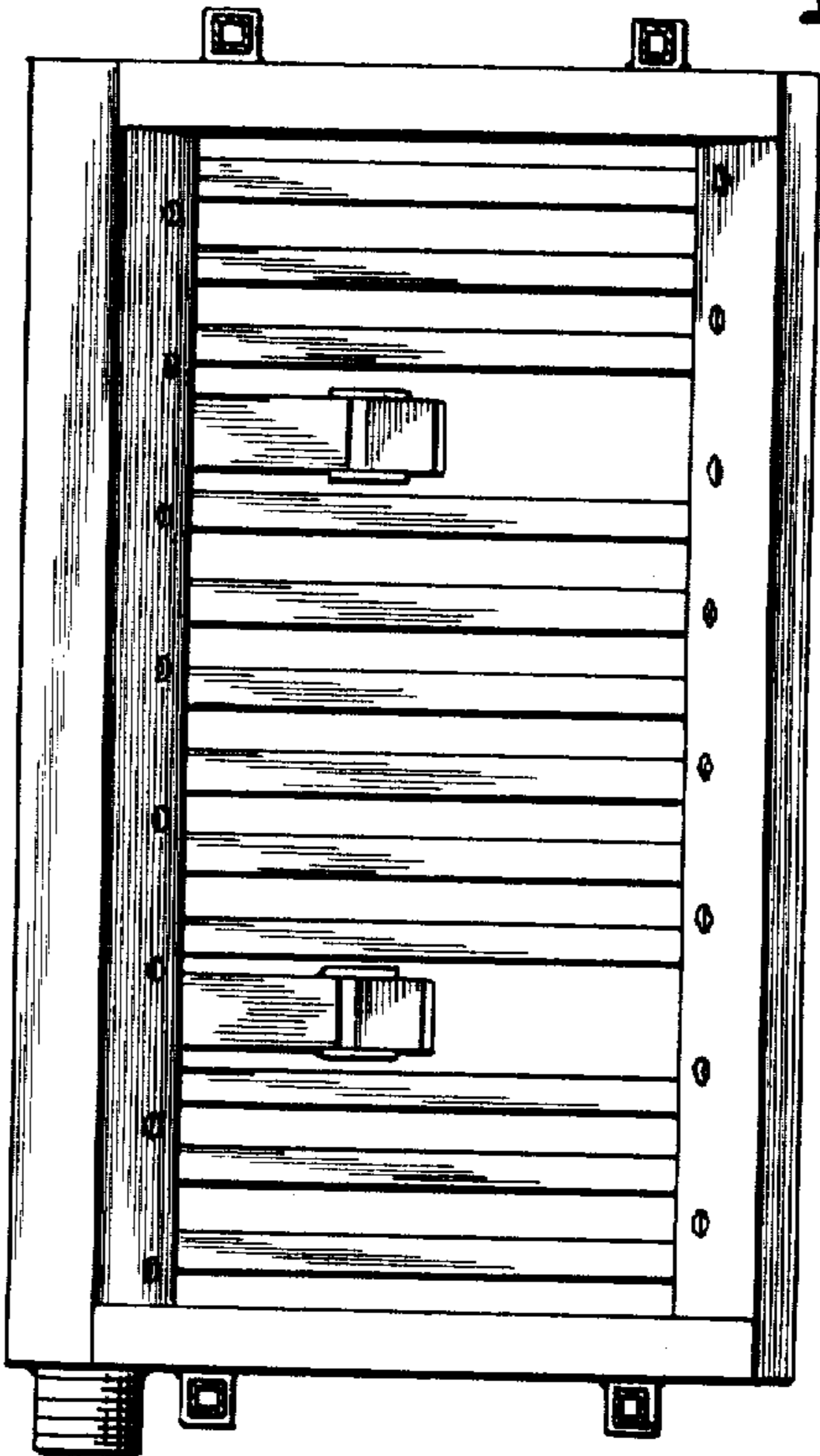

FIG. 4

