

[54] MOTORTRICYCLE

[75] Inventor: Atsushi Ishiyama, Tokyo, Japan

[73] Assignee: Yamaha Hatsudoki Kabushiki Kaisha, Japan

[**] Term: 14 Years

[21] Appl. No.: 70,618

[22] Filed: Aug. 29, 1979

[30] Foreign Application Priority Data

Mar. 6, 1979 [JP] Japan 54-8453

[51] Int. Cl. D12-11

[52] U.S. Cl. D12/110

[58] Field of Search D12/110, 112, 85; 180/215, 211, 210

[56] References Cited

U.S. PATENT DOCUMENTS

D. 254,366 3/1980 Ekuan D12/110

OTHER PUBLICATIONS

Cycle World, 3/78, p. 94, Honda ATC-70 Motortricycle, center right side of page.

American Bicyclist & Motorcyclist, 6/78, p. 51, rear Fender on Huffy "Bandit" Bicycle, bottom right side of page.

Primary Examiner—James M. Gandy
Attorney, Agent, or Firm—Ostrolenk, Faber, Gerb & Soffen

[57] CLAIM

The ornamental design for a motortricycle, as shown.

DESCRIPTION

FIG. 1 is a right side elevational view of a motortricycle showing my new design;

FIG. 2 is a left side elevational view thereof;

FIG. 3 is a top plan view thereof;

FIG. 4 is a front elevational view thereof;

FIG. 5 is a rear elevational view thereof; and

FIG. 6 is a perspective view thereof.

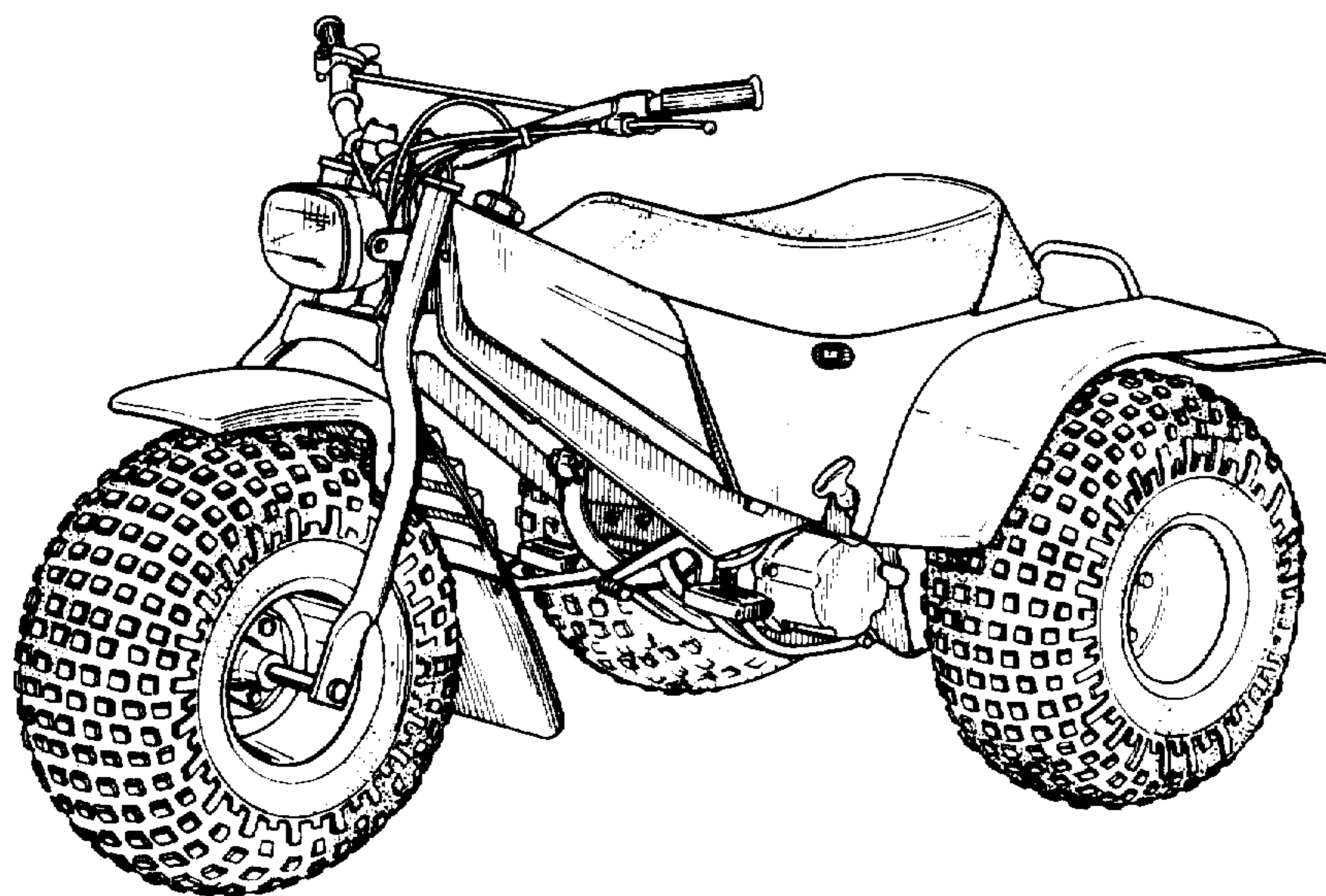

FIG. 1

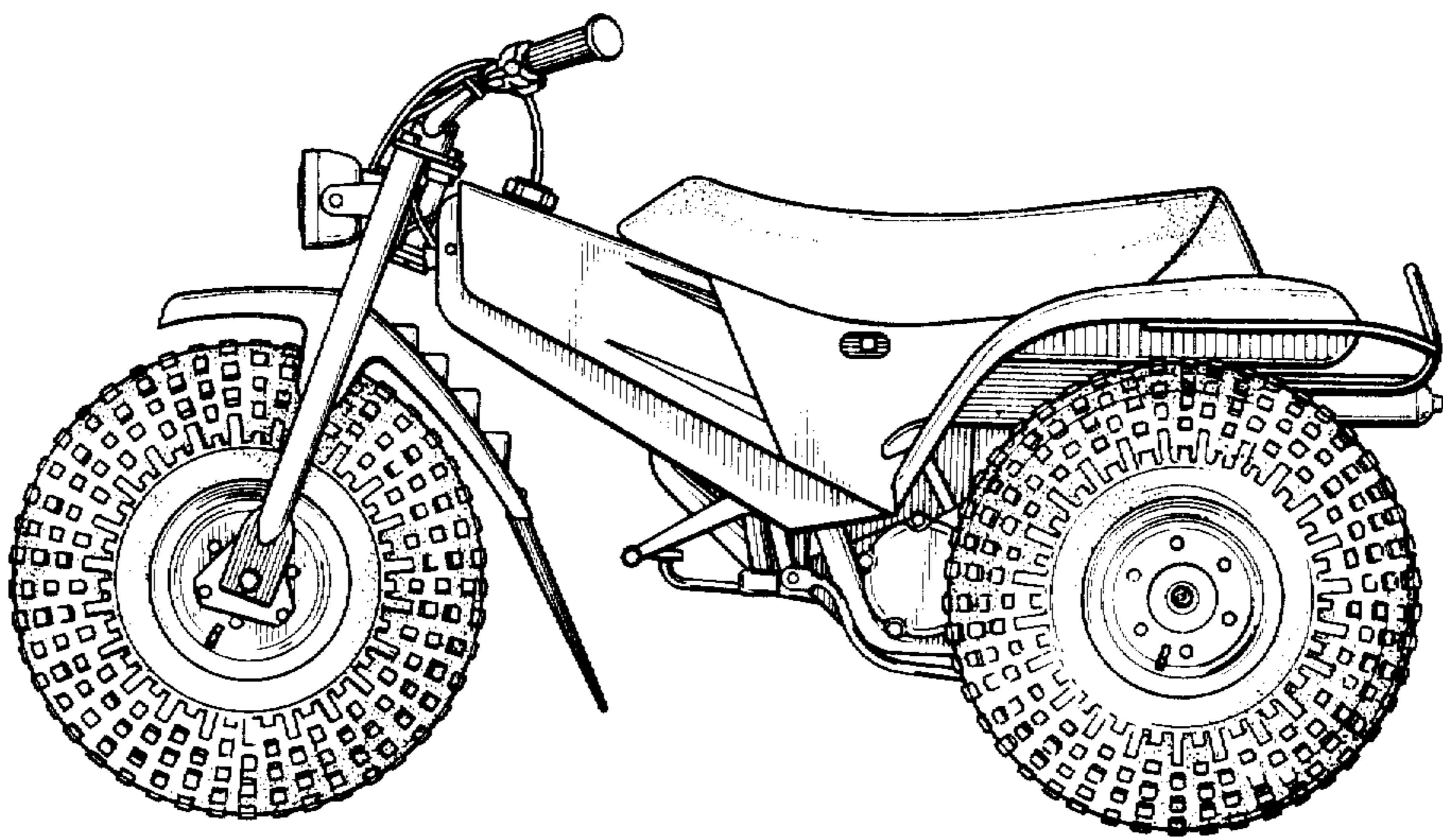

FIG. 2

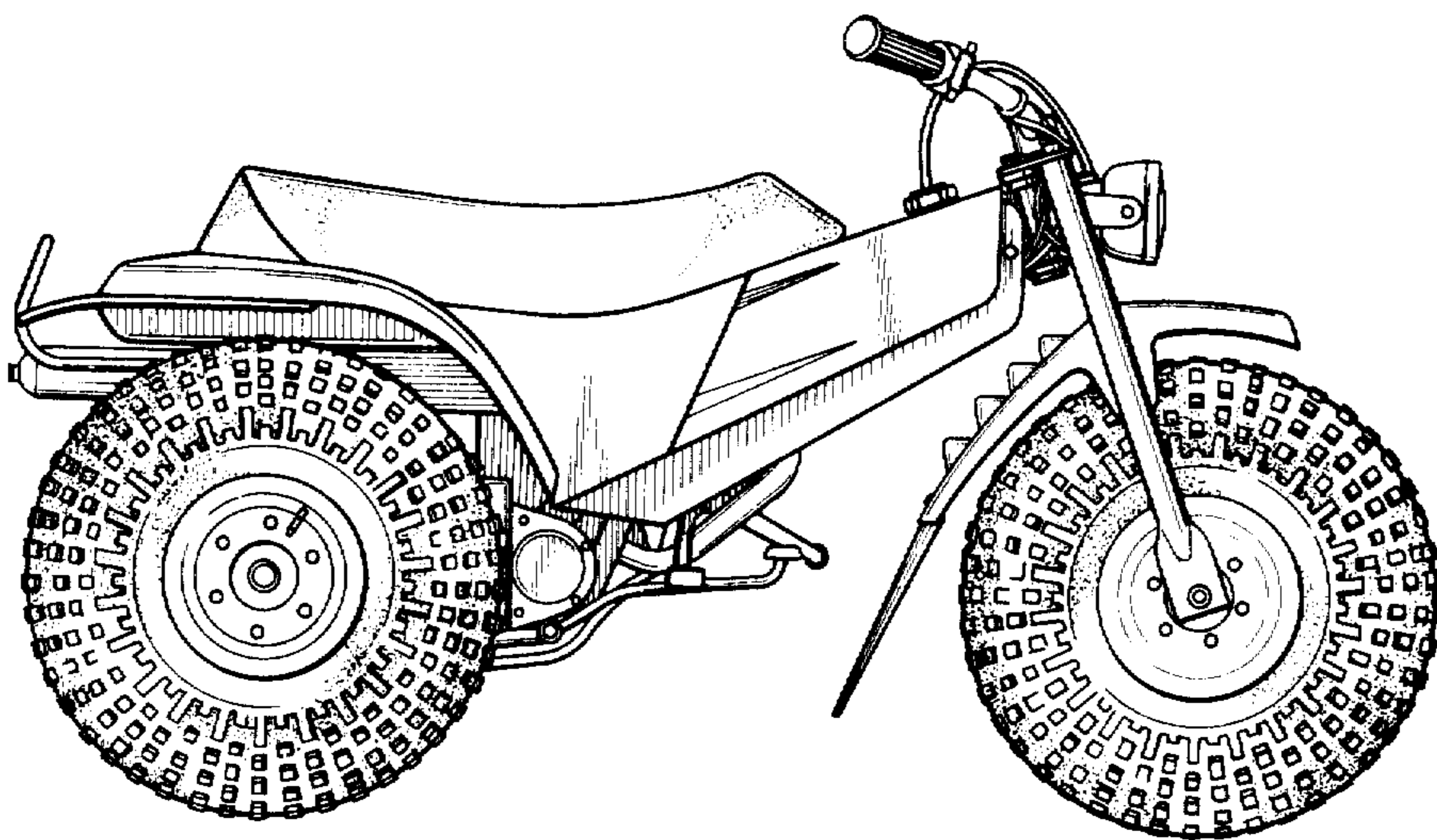

FIG. 3

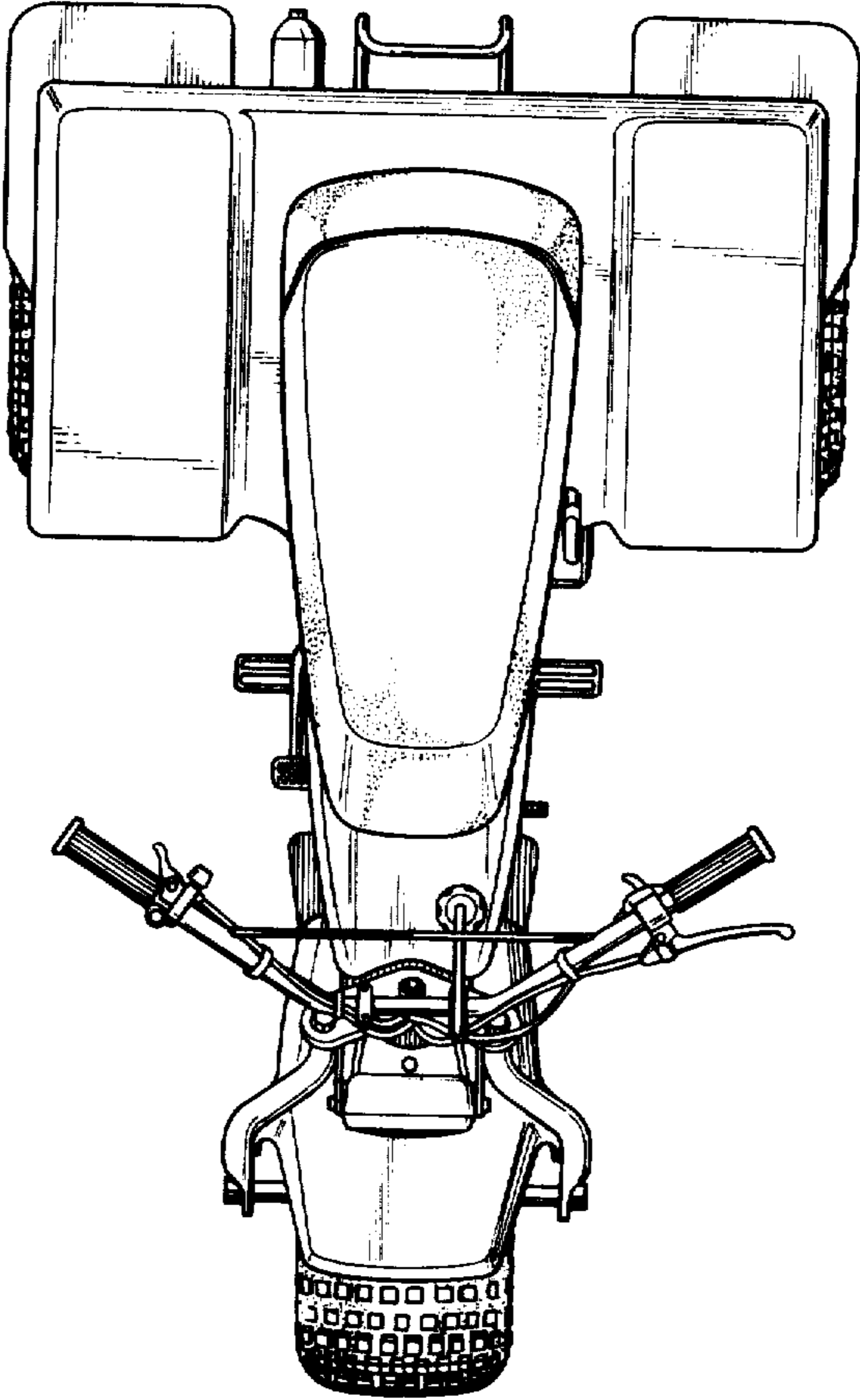

FIG. 4

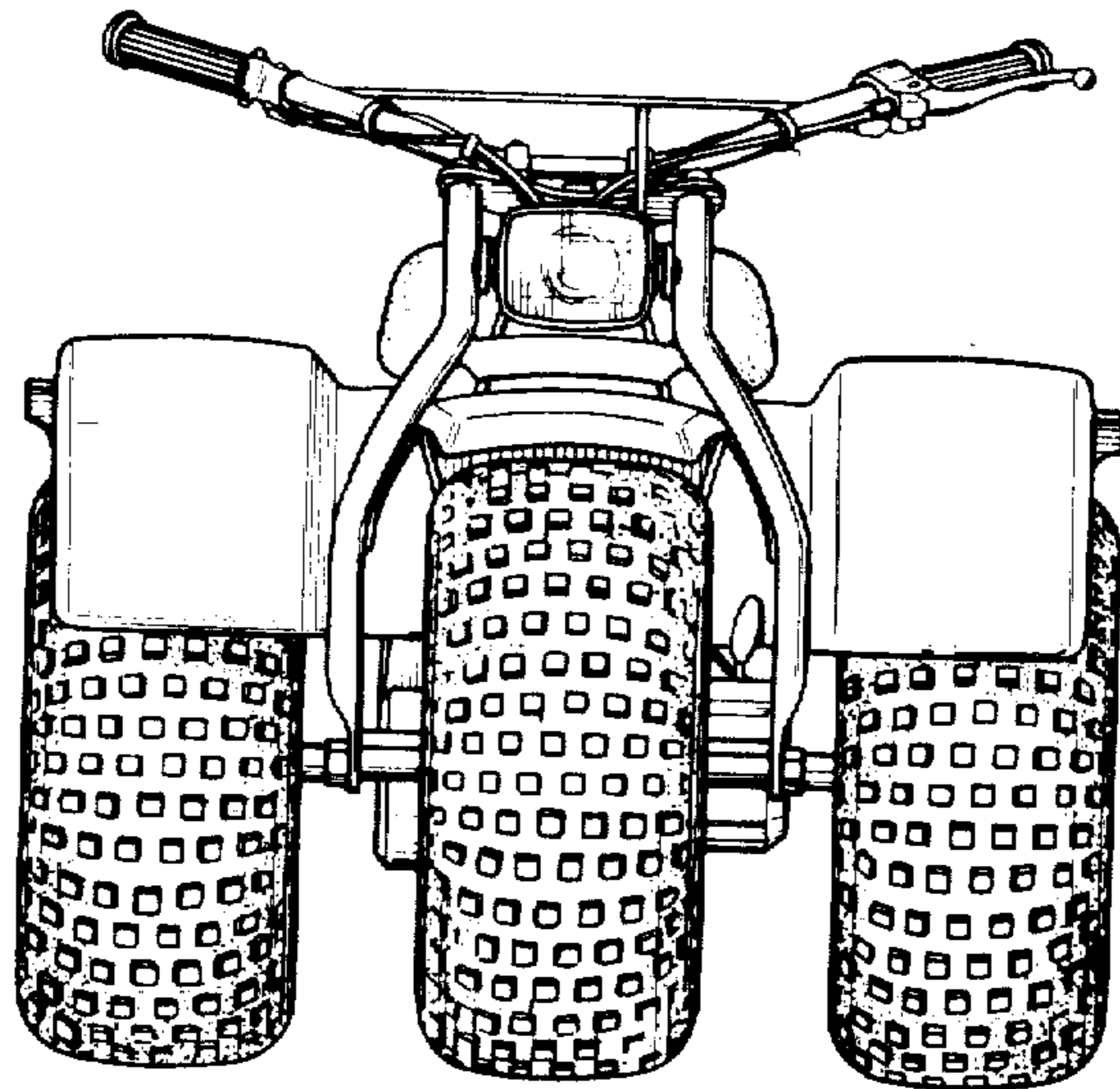

FIG. 5

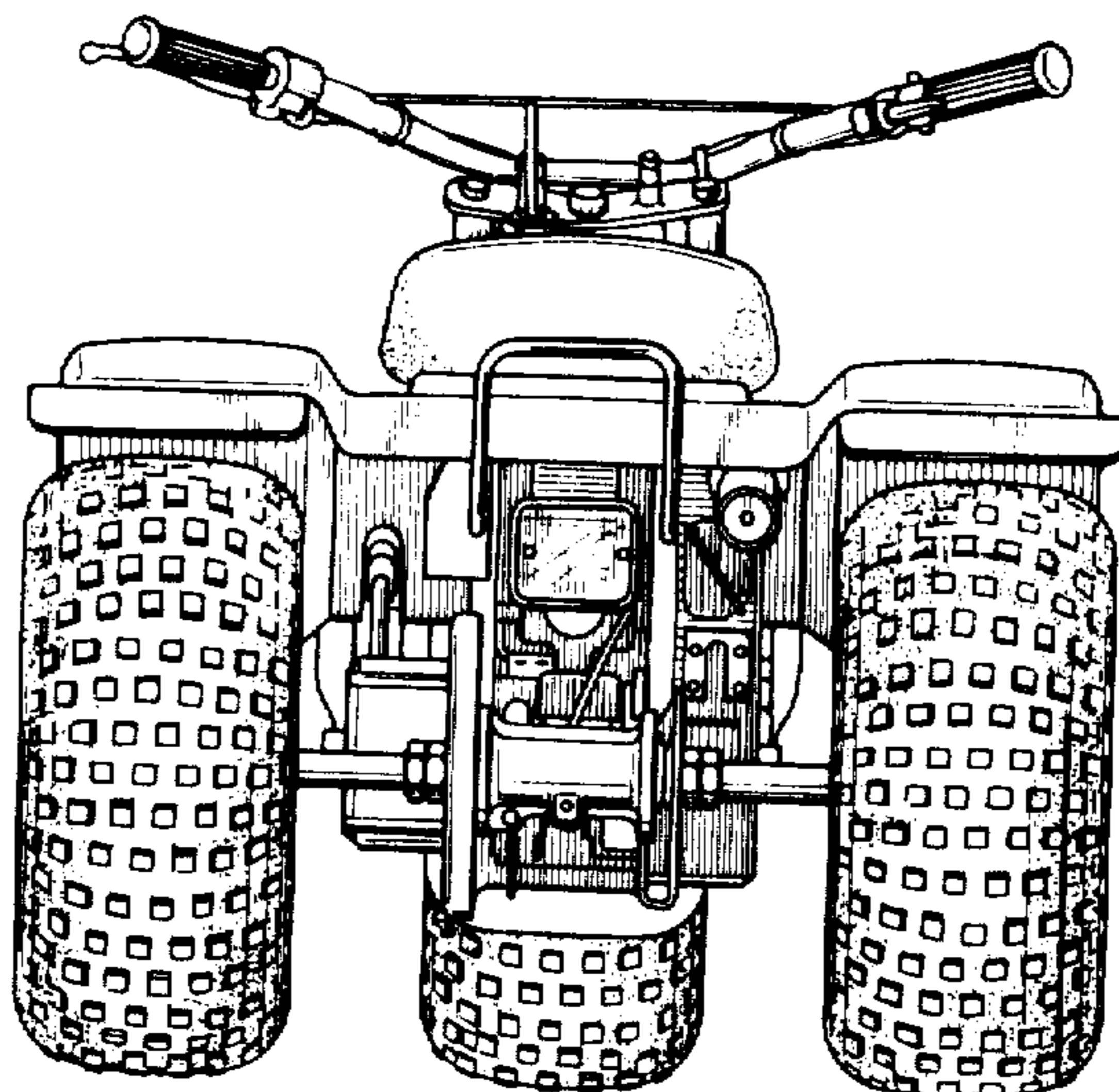

FIG. 6

