

[54] **FOUR WHEEL TANDEM TROLLEY**

[76] Inventor: **John F. Miller**, P.O. Box 277,
Howell, Mich. 48843

[**] Term: **14 Years**

[21] Appl. No.: **20,663**

[22] Filed: **Mar. 15, 1979**

[51] Int. Cl. **D12-05**

[52] U.S. Cl. **D34/35**

[58] Field of Search **D12/54, 60; D8/373;**
105/150, 152, 154, 155; 104/93

[56] **References Cited**

U.S. PATENT DOCUMENTS

876,486 1/1908 Pfaffenbach 105/152

OTHER PUBLICATIONS

Material Flow Inc. Catalog No. 762, ©1976, p. 86,
Trolley, bottom left side of page.

Primary Examiner—James M. Gandy
Attorney, Agent, or Firm—Burton, Parker & Schramm

[57] **CLAIM**

The ornamental design for a four wheel tandem trolley,
as shown.

DESCRIPTION

FIG. 1 is a front elevational view of a four wheel tan-
dem trolley showing my new design;
FIG. 2 is a rear elevational view thereof;
FIG. 3 is a top plan view thereof;
FIG. 4 is a side elevational view thereof; and
FIG. 5 is a bottom plan view thereof.

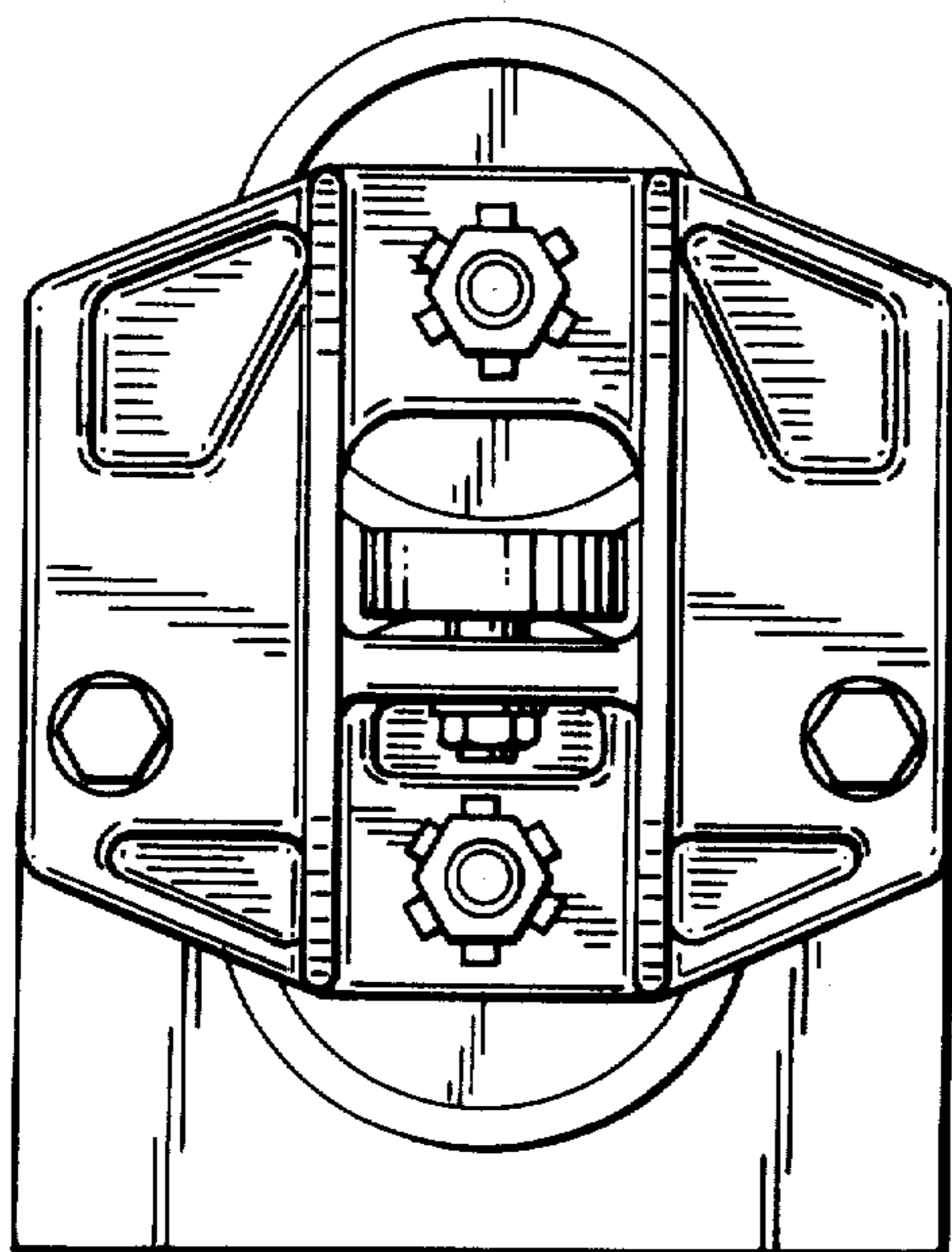

FIG. 1

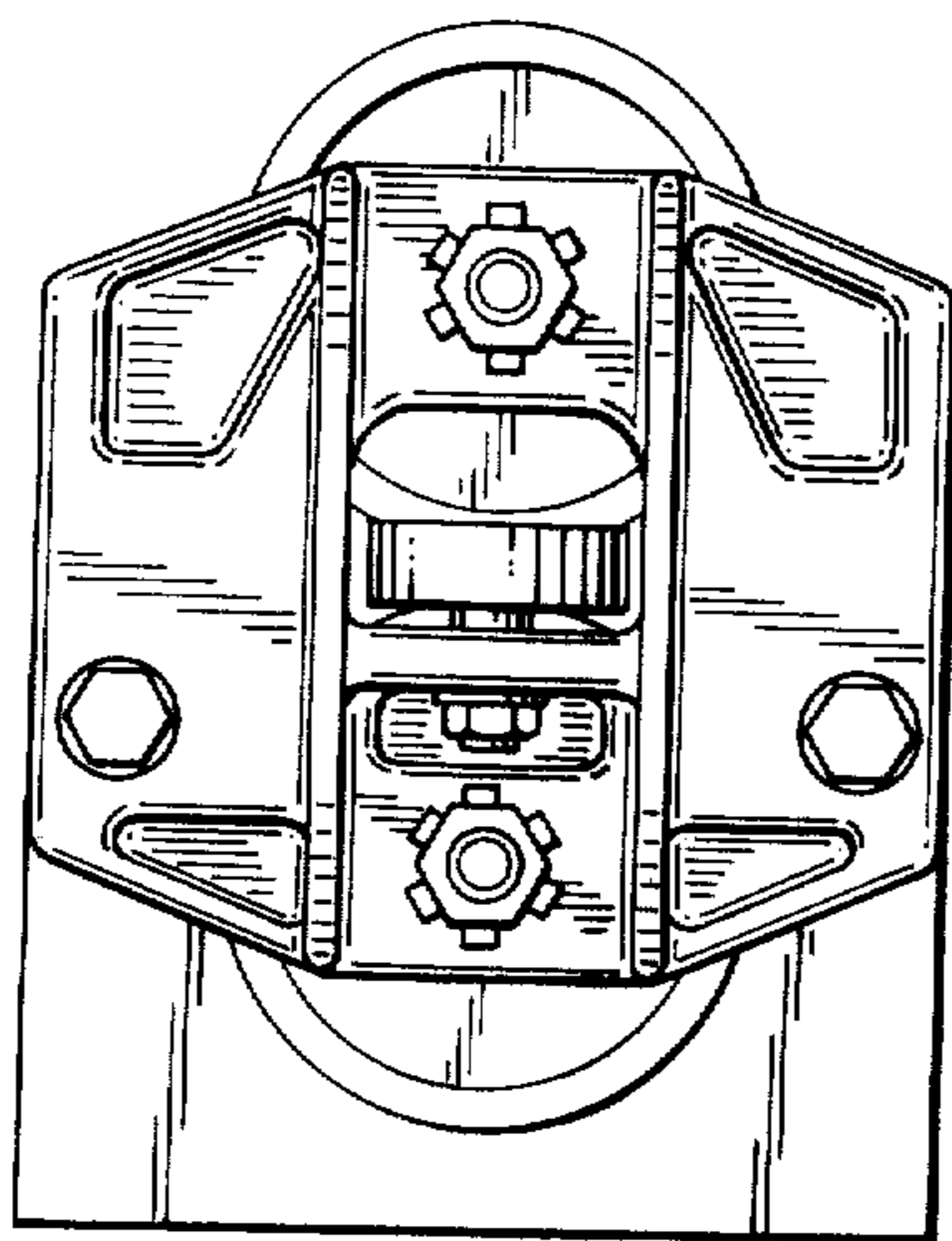

FIG. 2

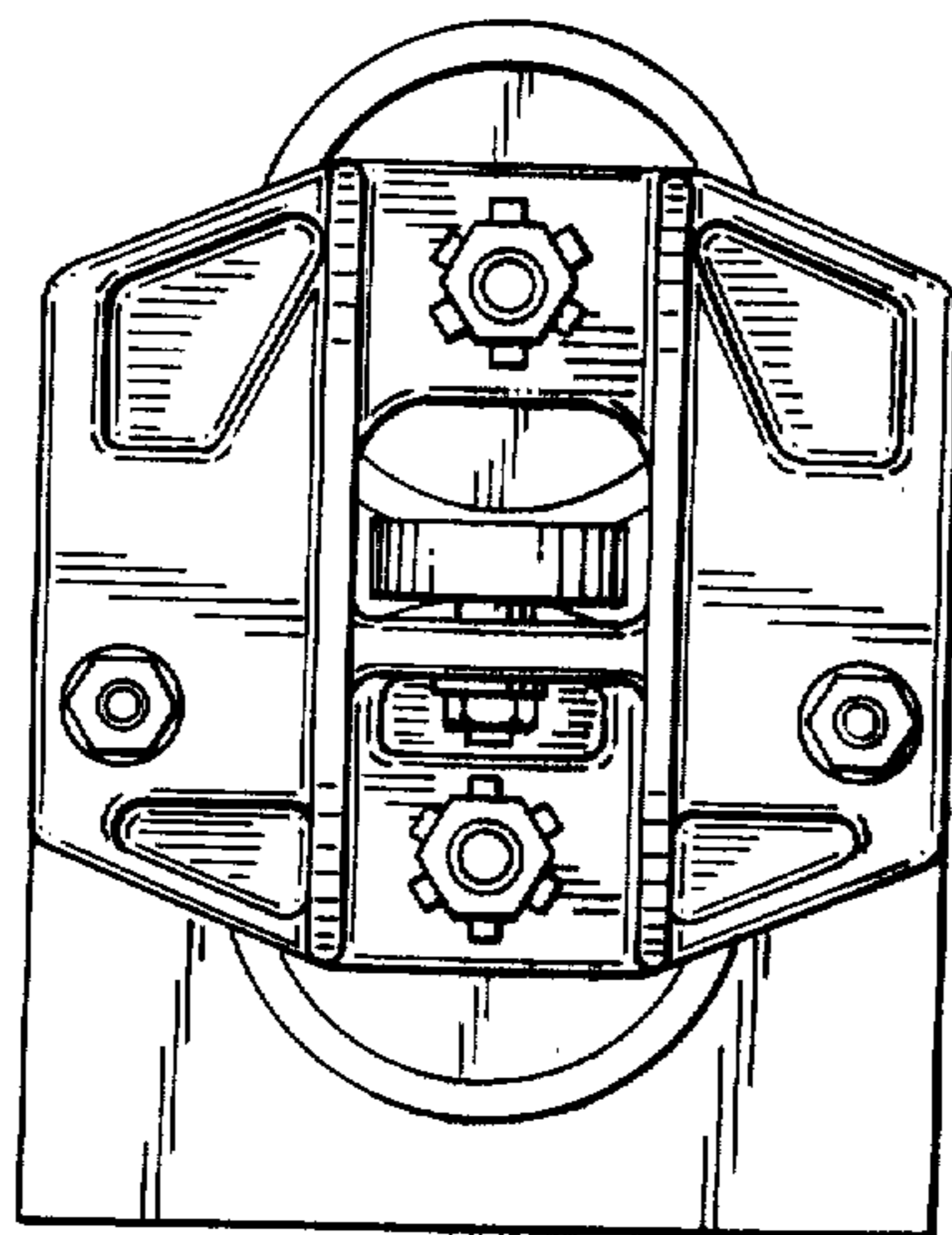

FIG. 3

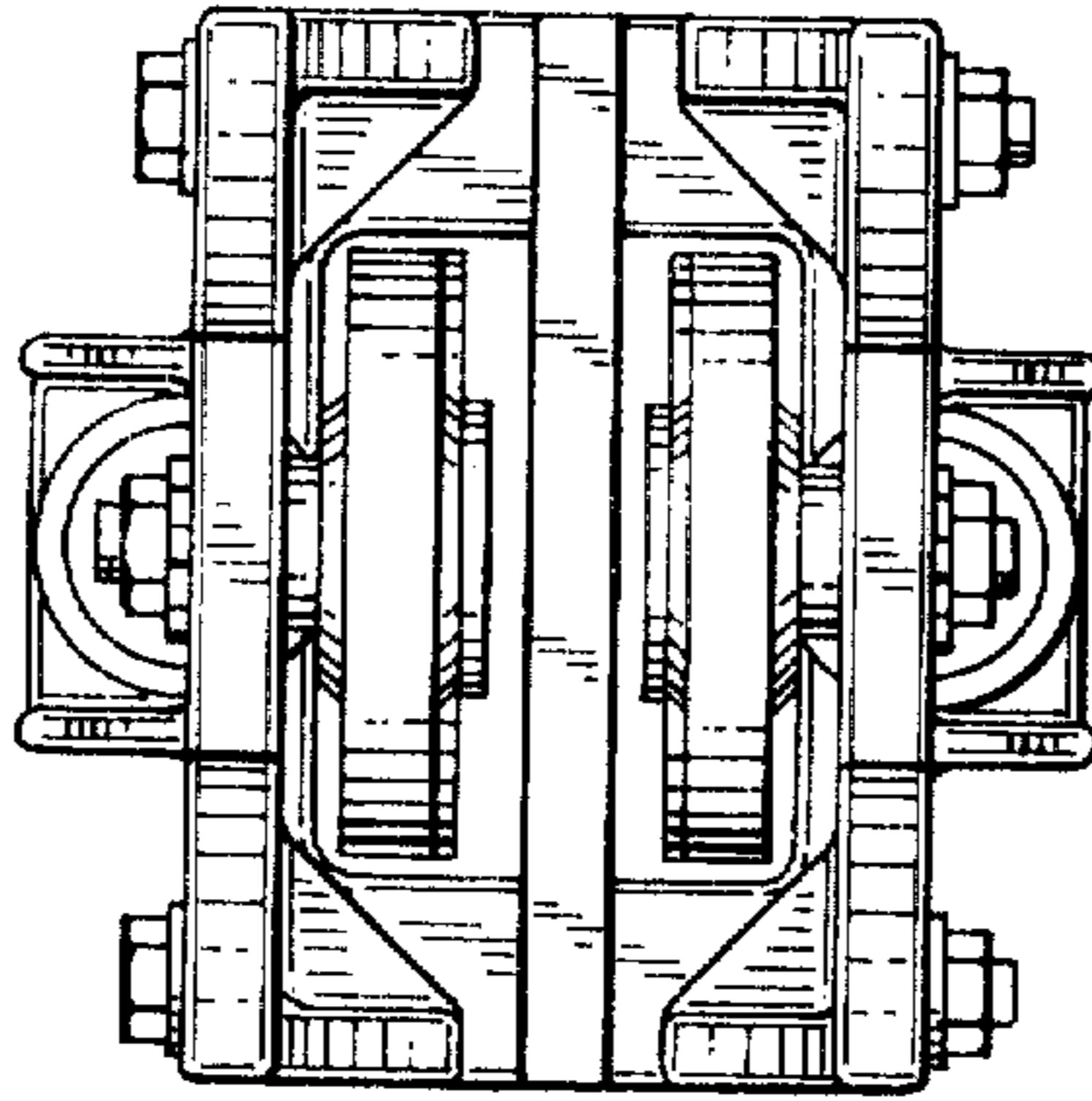

FIG. 4

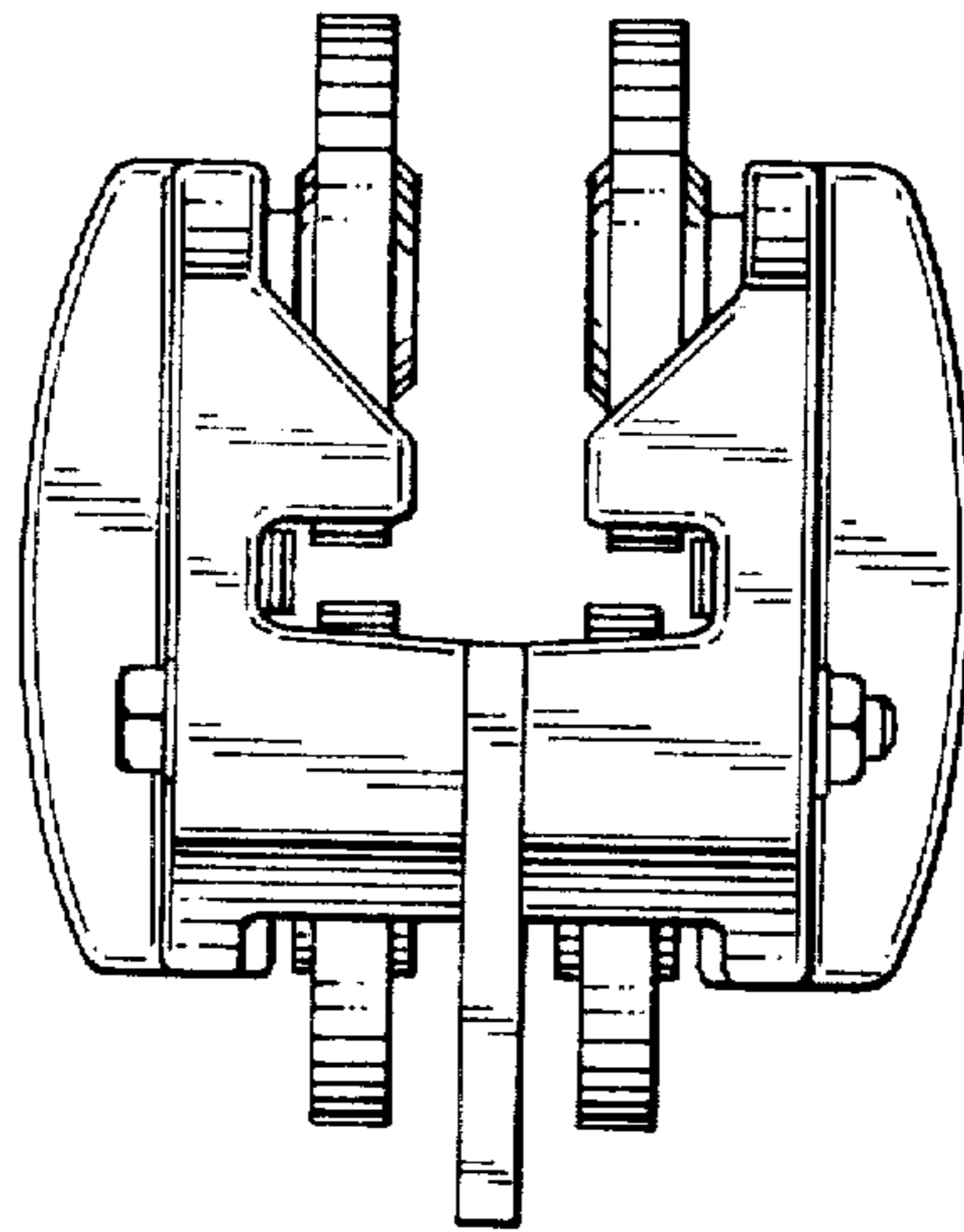

FIG. 5

