

[54] MIXER-COOKER KITCHEN MACHINE

[75] Inventor: Oswald Gibiec, Wuppertal, Fed. Rep. of Germany

[73] Assignee: Vorwerk & Co. Elektrowerke KG, Wuppertal, Fed. Rep. of Germany

[\*\*] Term: 14 Years

[21] Appl. No.: 24,313

[22] Filed: Mar. 27, 1979

[30] Foreign Application Priority Data

Dec. 4, 1978 [DE] Fed. Rep. of Germany ..... 14146

[51] Int. Cl. .... D07-04

[52] U.S. Cl. .... D7/159; D7/94; D7/154

[58] Field of Search ..... 74/16; 241/282.2; D7/153, 154, 155, 156, 158, 159, 160, 94; D15/92, 95, 98, 99, 100, 104

[56] References Cited

U.S. PATENT DOCUMENTS

|            |        |                         |        |
|------------|--------|-------------------------|--------|
| D. 182,306 | 3/1958 | Rutan .....             | D7/154 |
| D. 191,152 | 8/1961 | Rawson, Jr. et al. .... | D7/154 |
| D. 232,694 | 9/1974 | Iwagami et al. ....     | D7/159 |
| D. 254,948 | 5/1980 | Besford .....           | D7/153 |
| D. 256,318 | 8/1980 | Levin .....             | D7/154 |

FOREIGN PATENT DOCUMENTS

314595 6/1956 Fed. Rep. of Germany ... 241/282.2

Primary Examiner—Winifred E. Herrmann  
Attorney, Agent, or Firm—Michael J. Striker

[57] CLAIM

The ornamental design for a mixer-cooker kitchen machine, substantially as shown and described.

DESCRIPTION

FIG. 1 is a perspective view, showing the front and right side of my mixer-cooker kitchen machine;  
FIG. 2 is a perspective view, showing the rear and right side thereof;  
FIG. 3 is a front elevation thereof;  
FIG. 4 is a rear elevation thereof;  
FIG. 5 is a right side elevation thereof; and  
FIG. 6 is a left side elevation thereof.  
The bottom is unornamented.

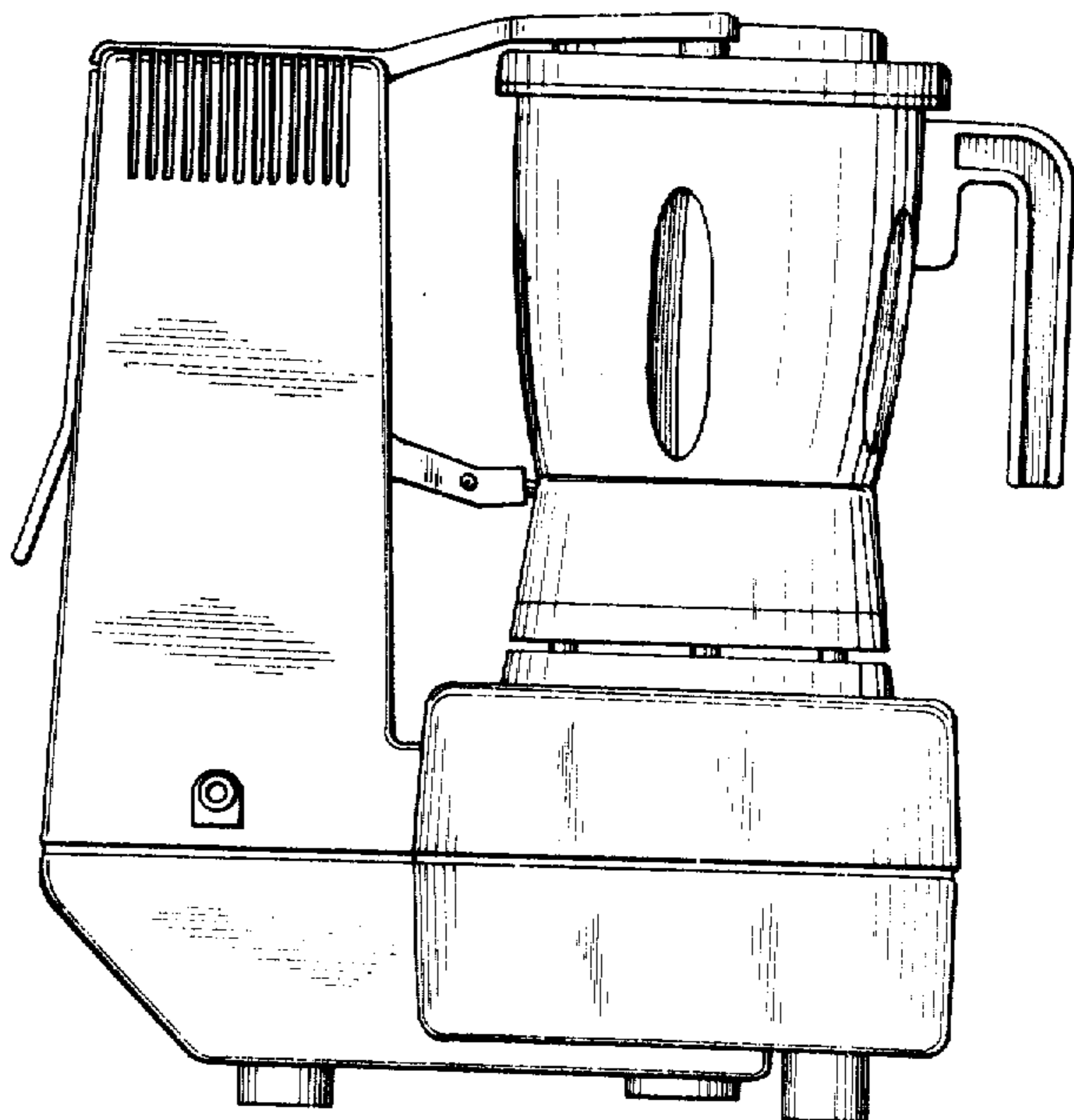
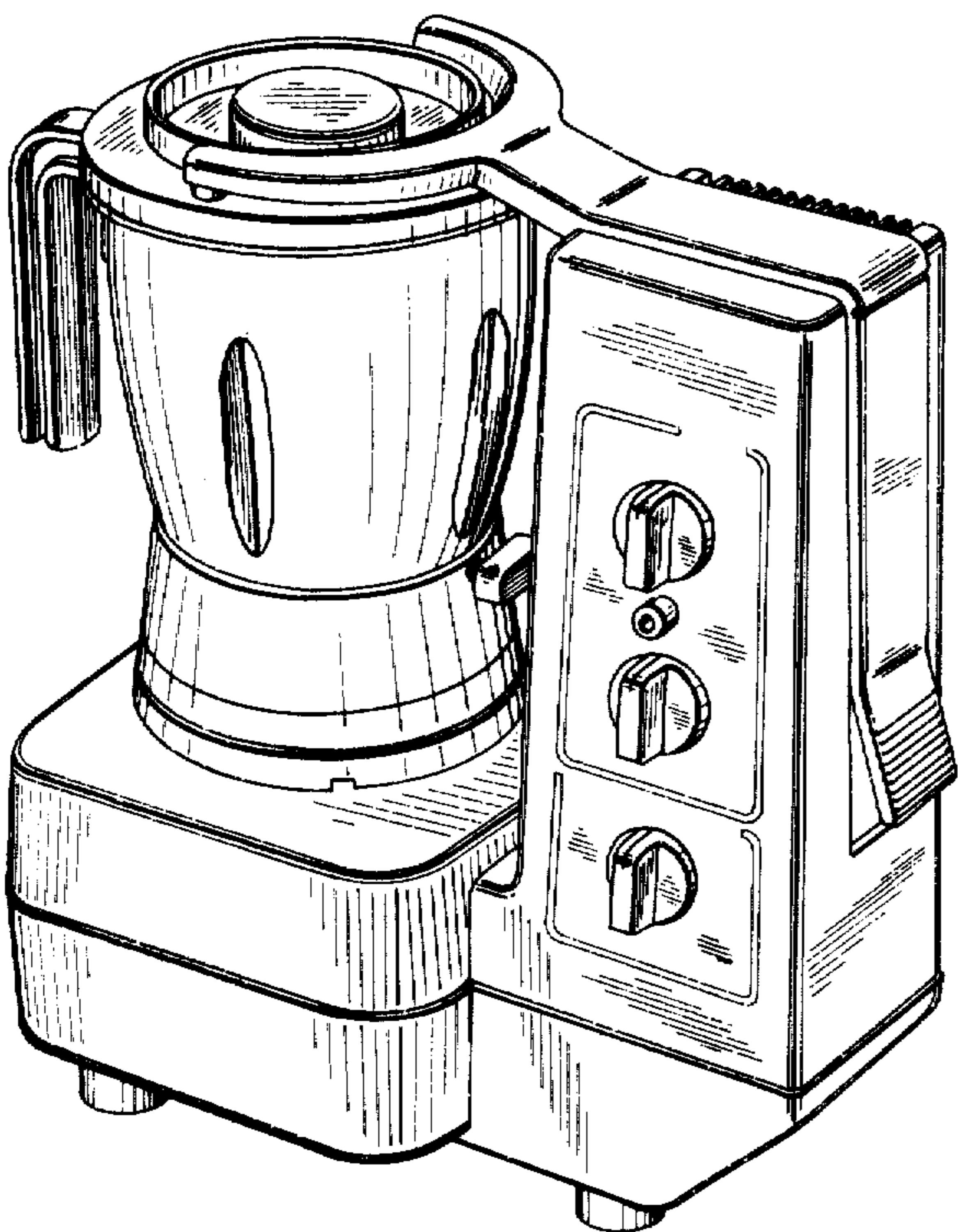

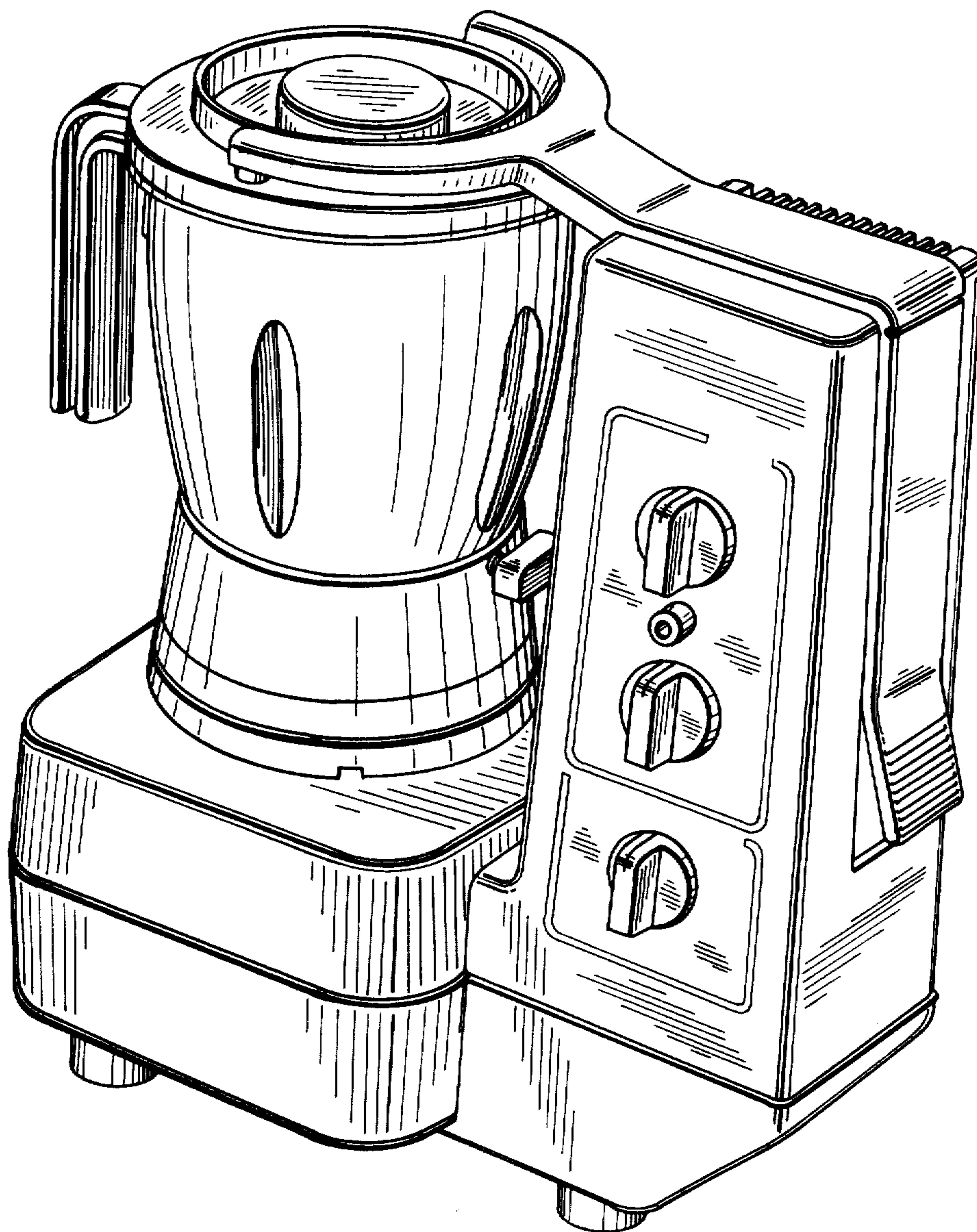

FIG. 1

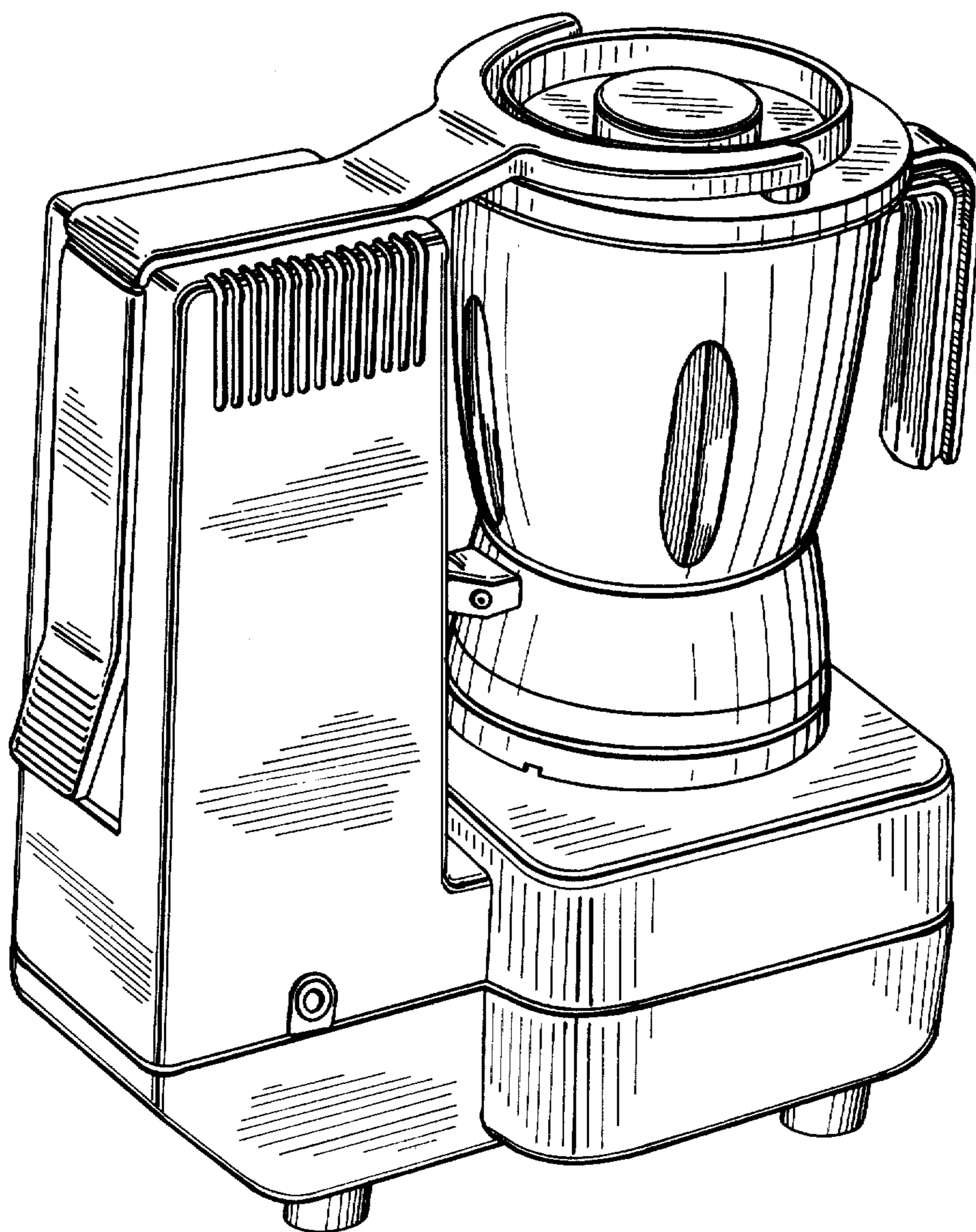

FIG. 2

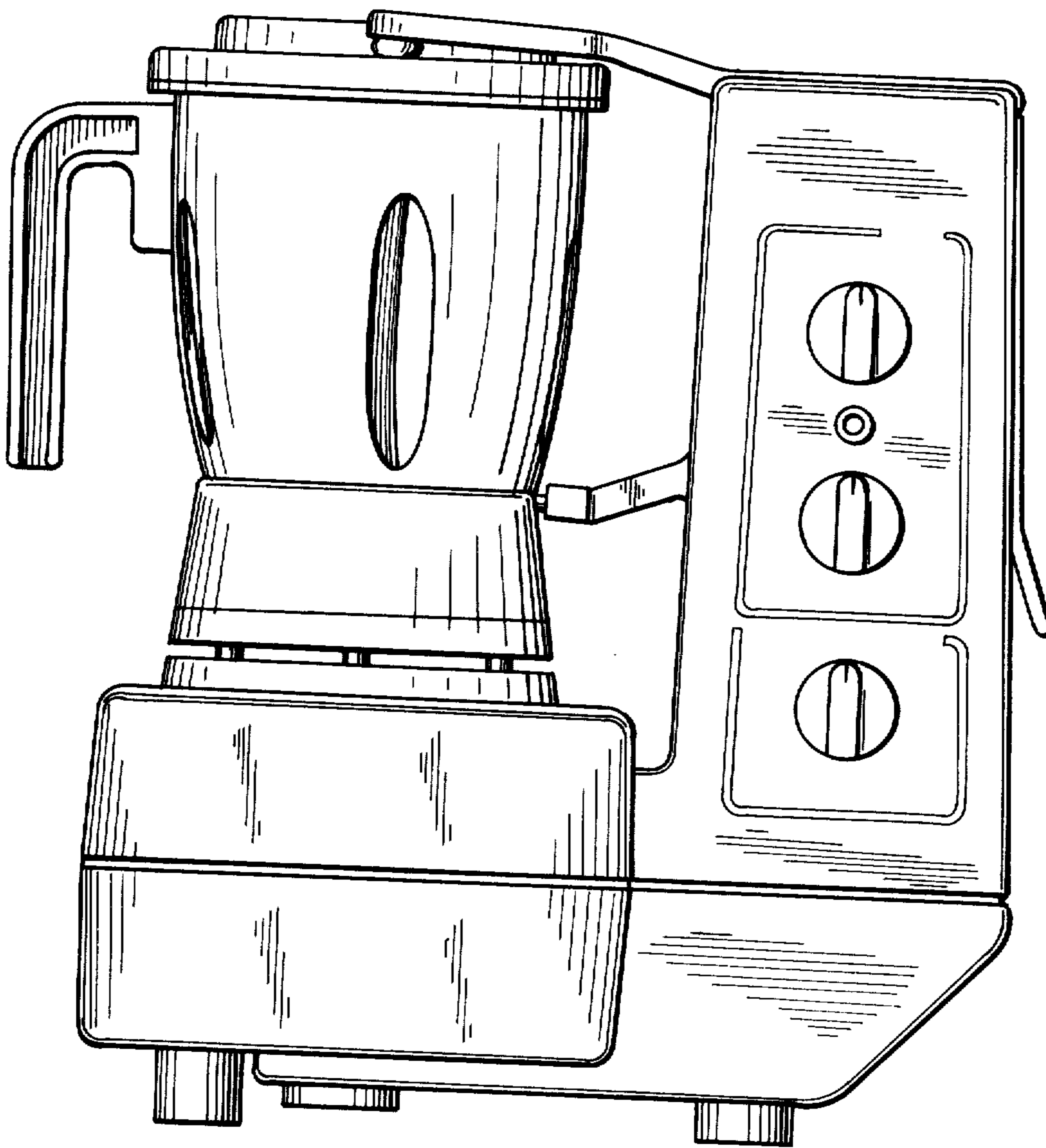

FIG. 3

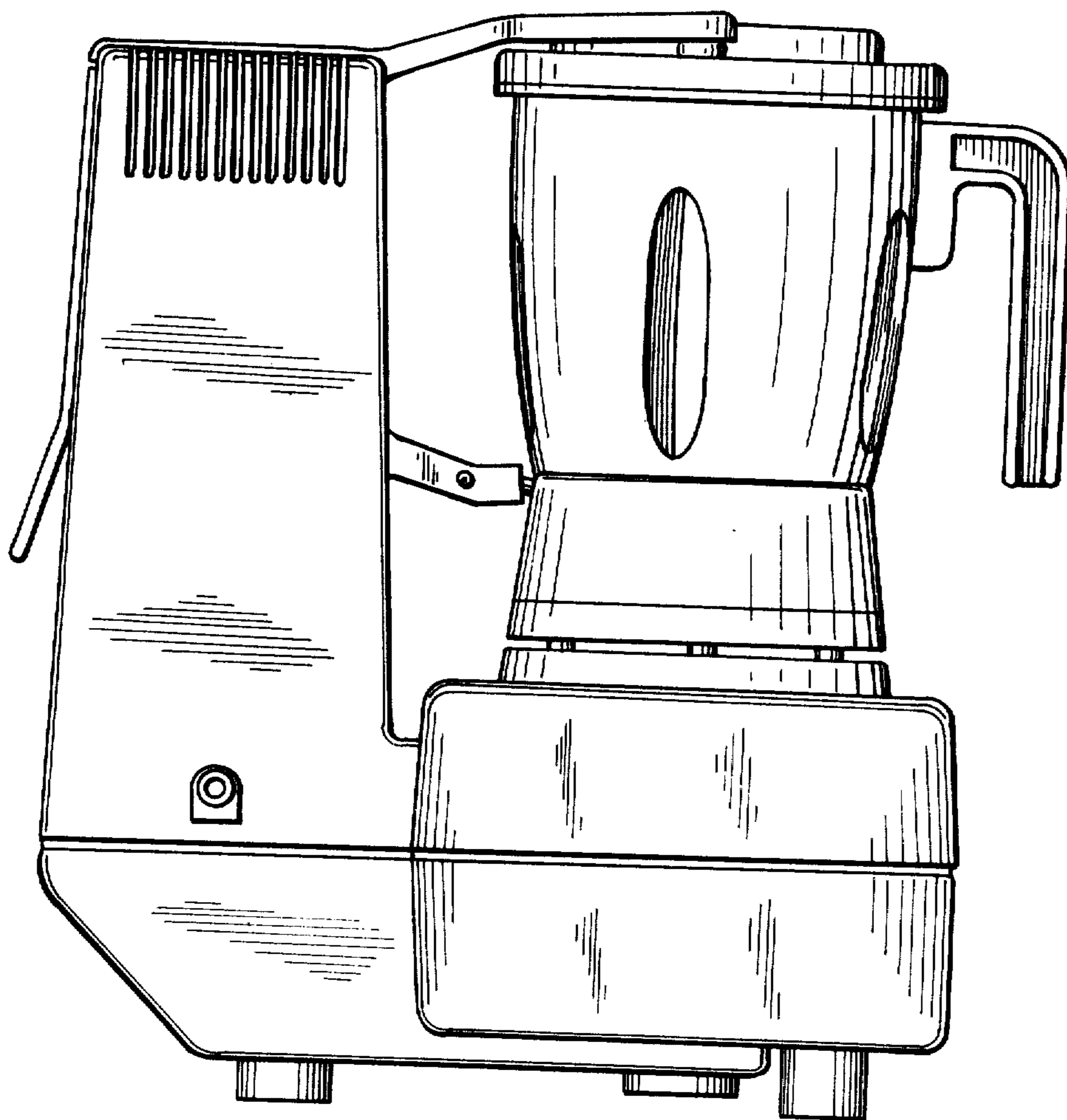

FIG. 4

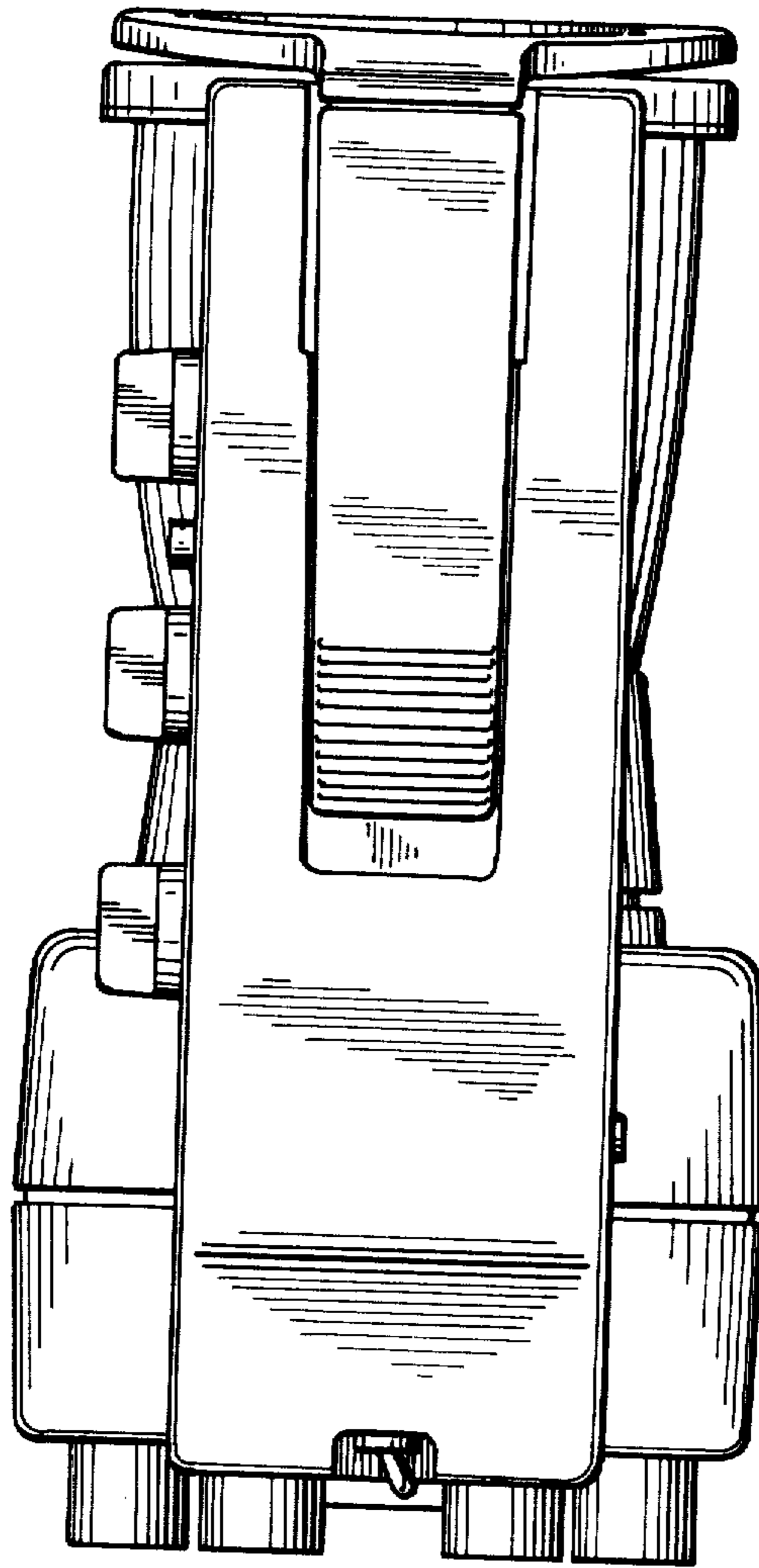

FIG. 5

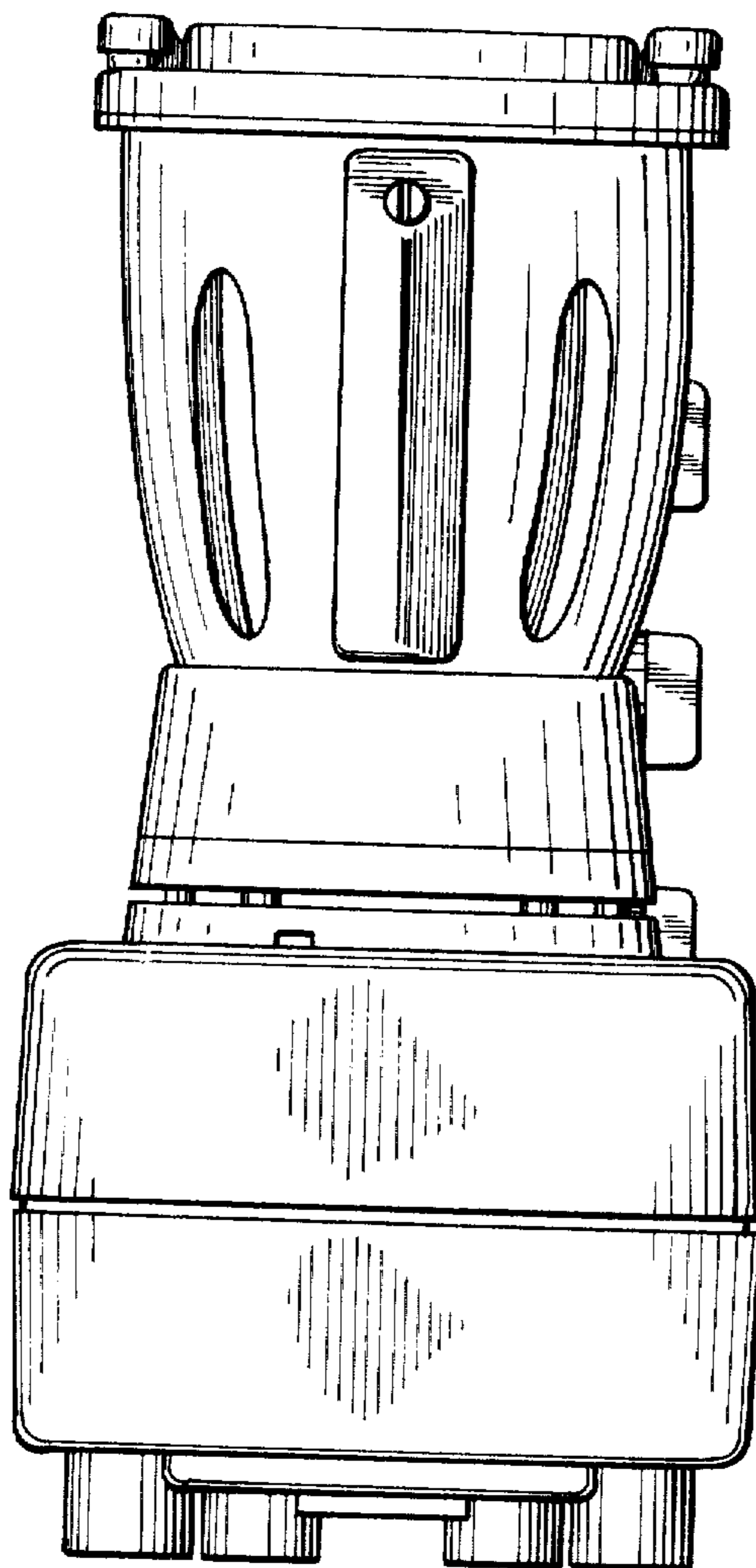

FIG. 6