

[54] STAND FOR A GUITAR

[76] Inventor: K. D. Mears, 219 Cottonwood St., Woodland, Calif. 95695

[**] Term: 14 Years

[21] Appl. No.: 36,782

[22] Filed: May 7, 1979

[51] Int. Cl. D6-06

[52] U.S. Cl. D6/85; D6/141; D6/151

[58] Field of Search D6/18, 19, 20, 25, 85, D6/184, 185, 141, 151, 153; D17/13, 20, 99; 248/441 R, 452, 121; 84/327

[56] References Cited

U.S. PATENT DOCUMENTS

D. 156,693 1/1950 Bergal D6/184

D. 226,699 4/1973 Blain D6/18
D. 230,385 2/1974 Steinmeier D6/20
3,737,137 6/1973 Sheehan 248/441 R

Primary Examiner—Joel Stearman
Assistant Examiner—Carmen H. Vales
Attorney, Agent, or Firm—Herbert E. Kidder

[57] CLAIM

The ornamental design for a stand for a guitar, as shown and described.

DESCRIPTION

FIG. 1 is a perspective view of a stand for a guitar showing my new design;
FIG. 2 is a left side elevational view thereof; the right side being a mirror image thereto;
FIG. 3 is a top plan view thereof;
FIG. 4 is a front elevational view thereof;
FIG. 5 is a rear elevational view thereof; and
FIG. 6 is a bottom plan view thereof.

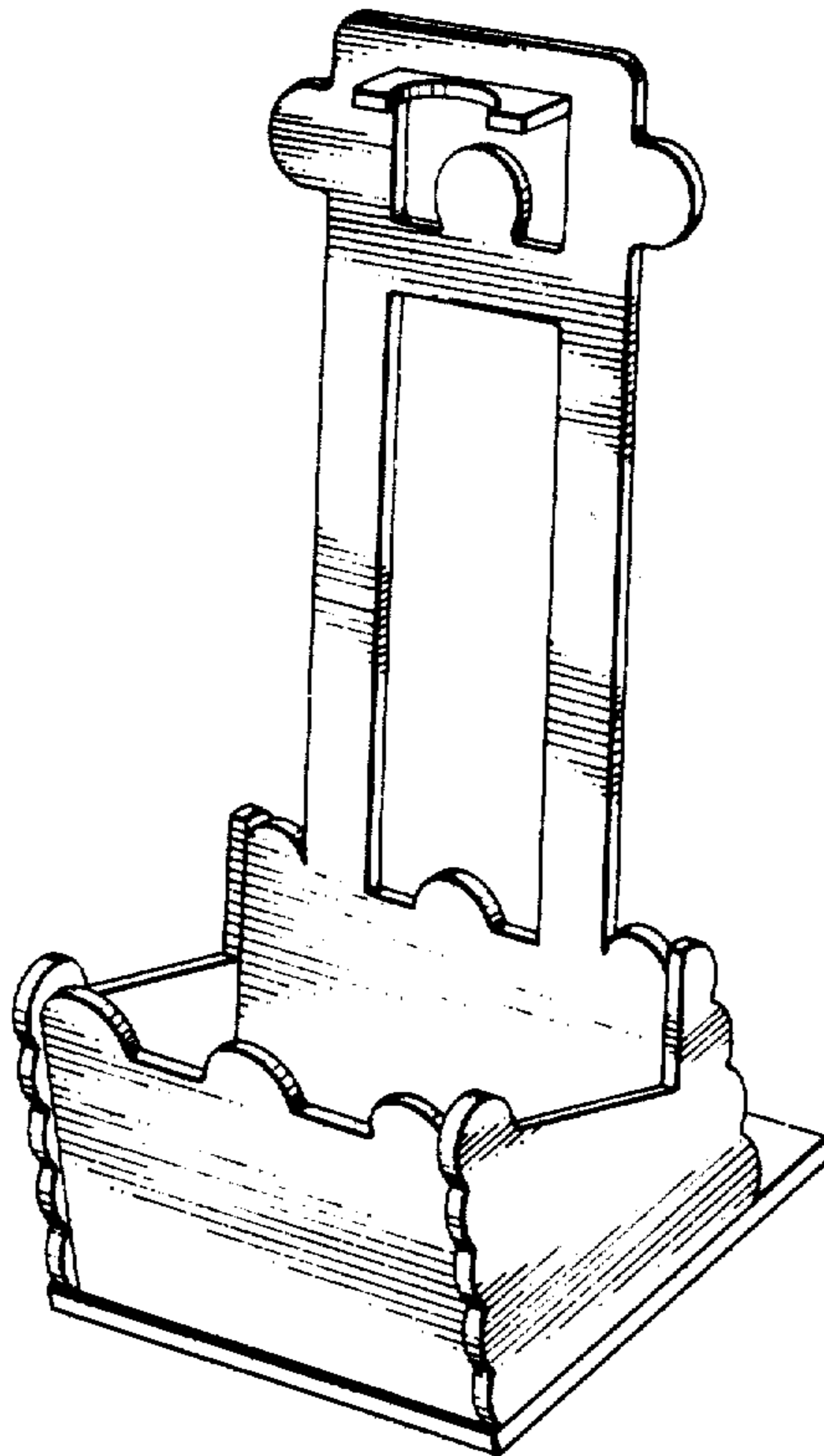

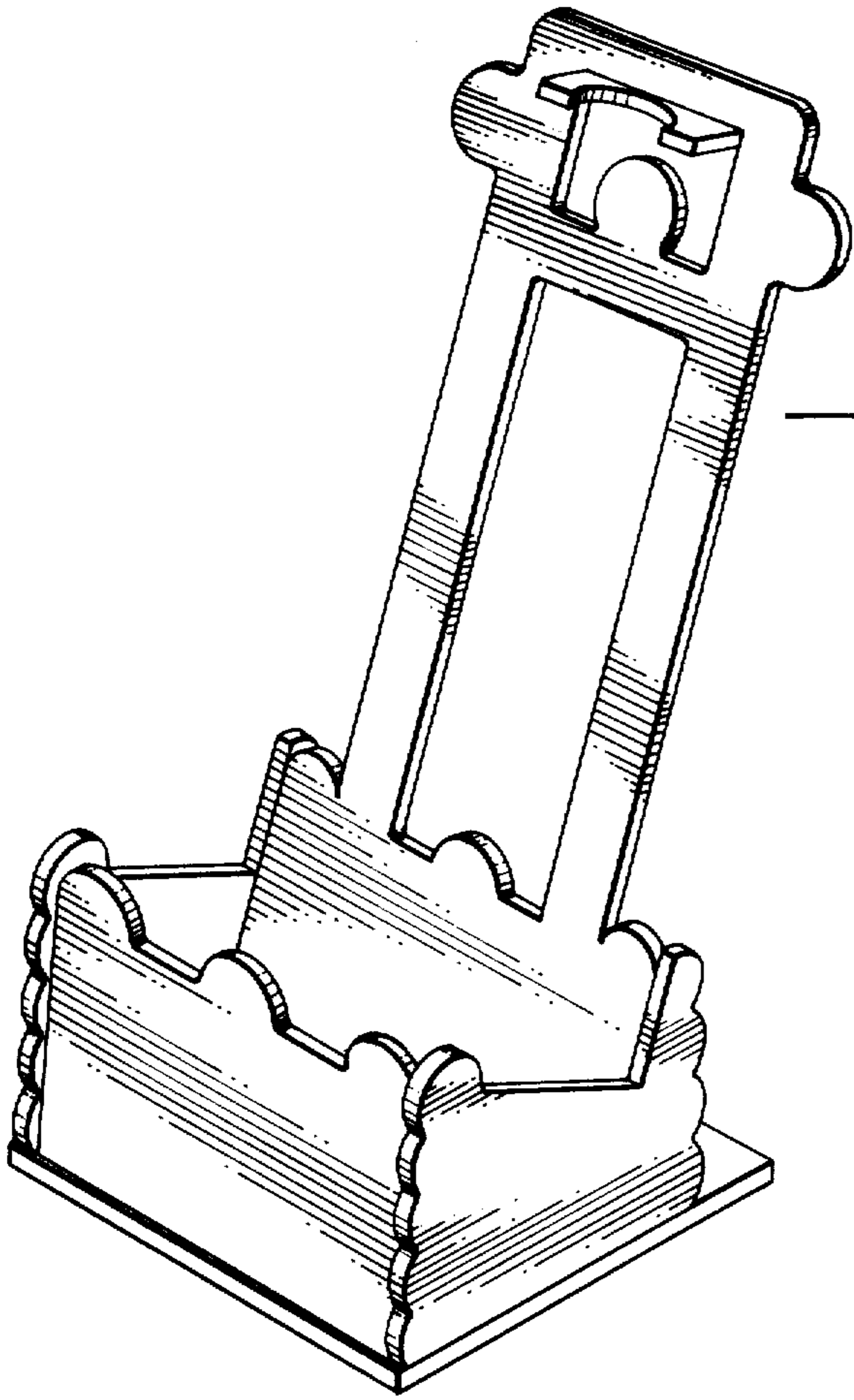

FIG. 1.

FIG. 2.

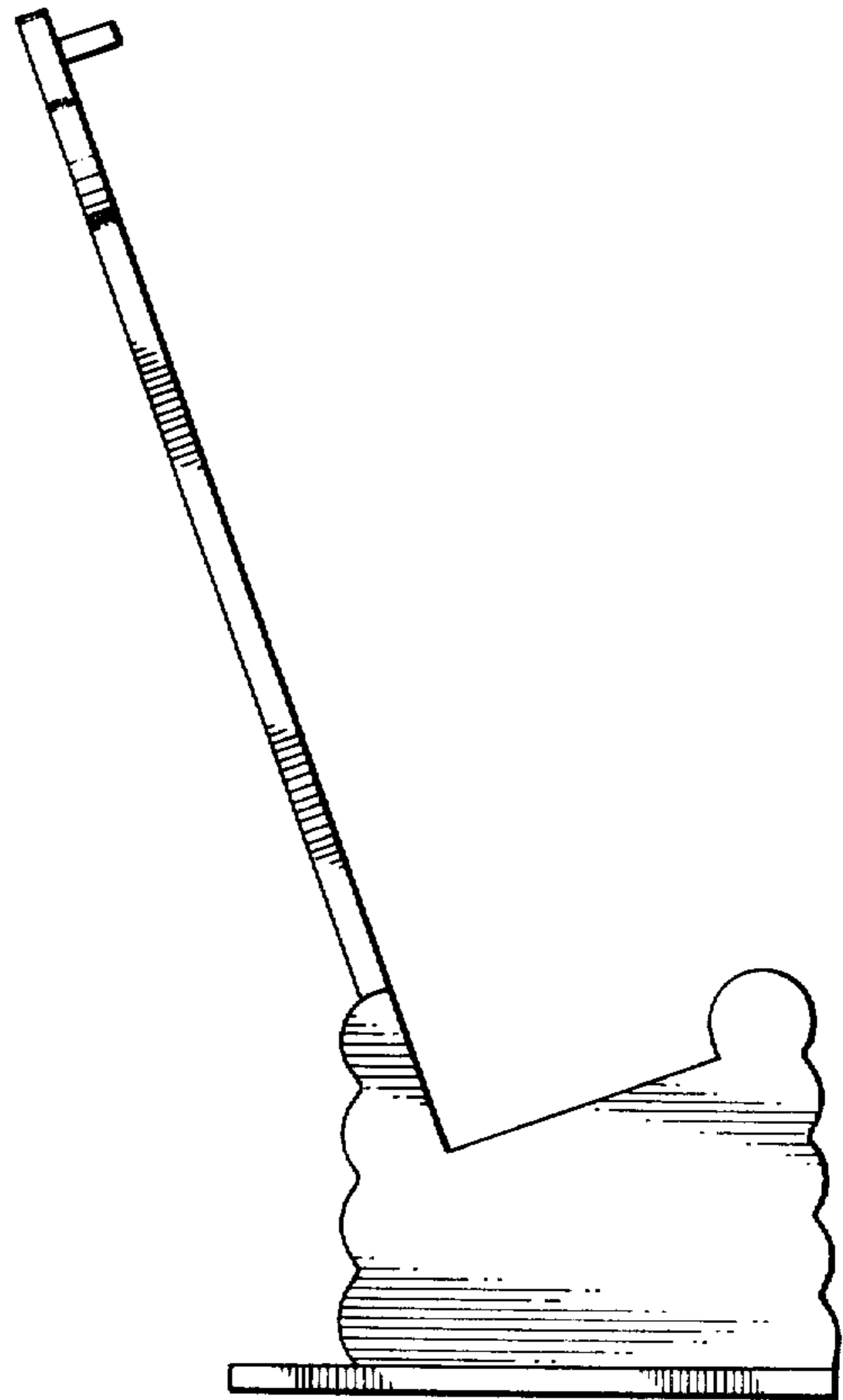
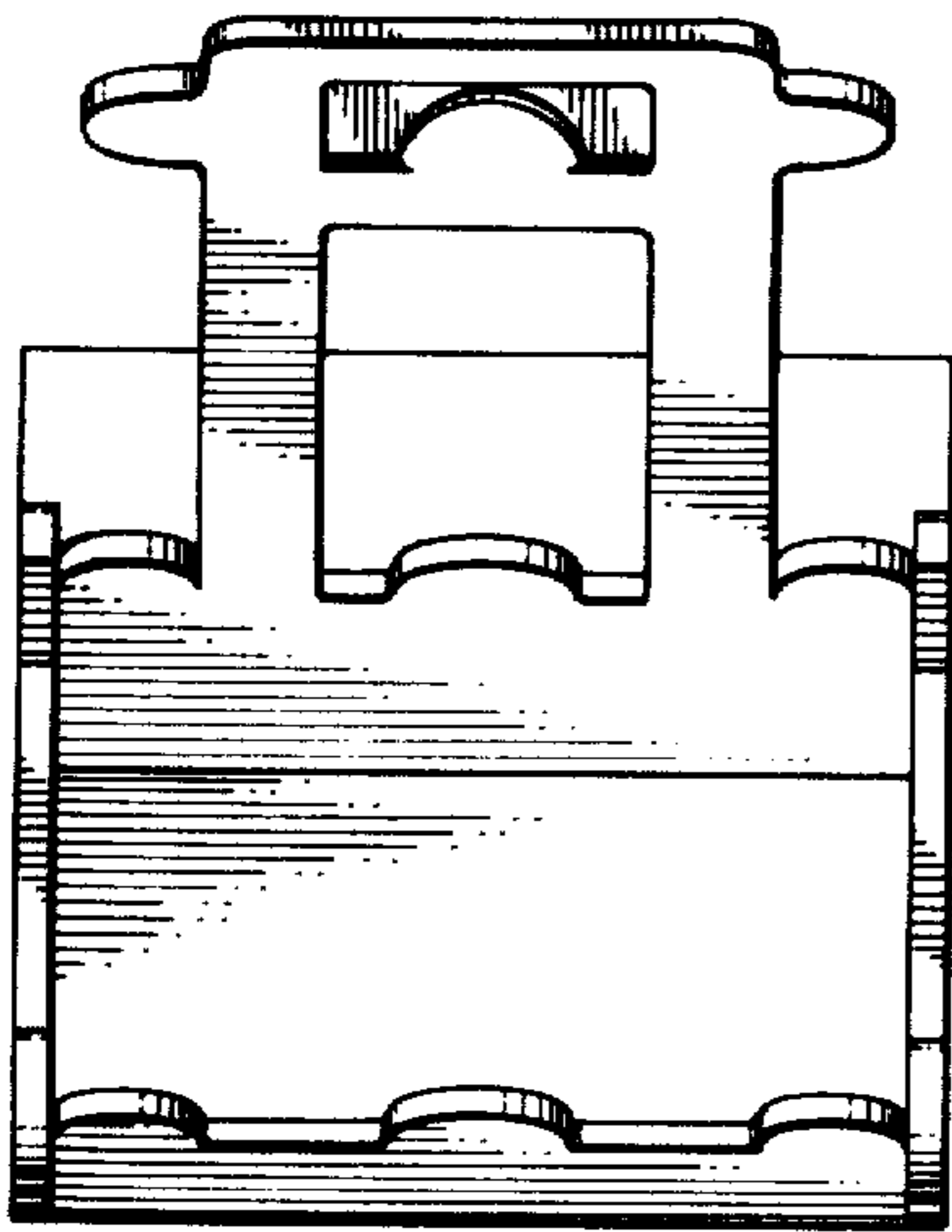

FIG. 3.



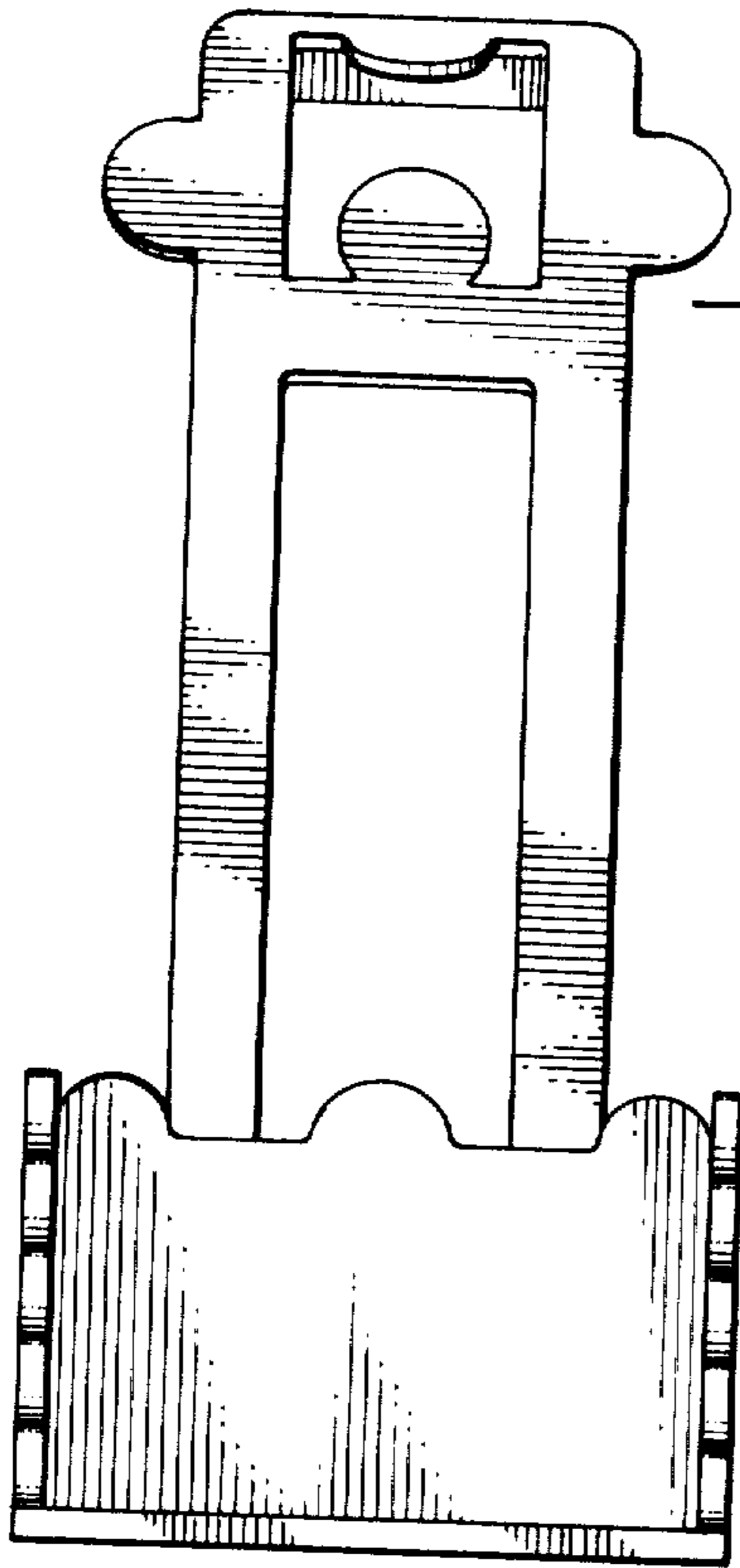

FIG. 4.

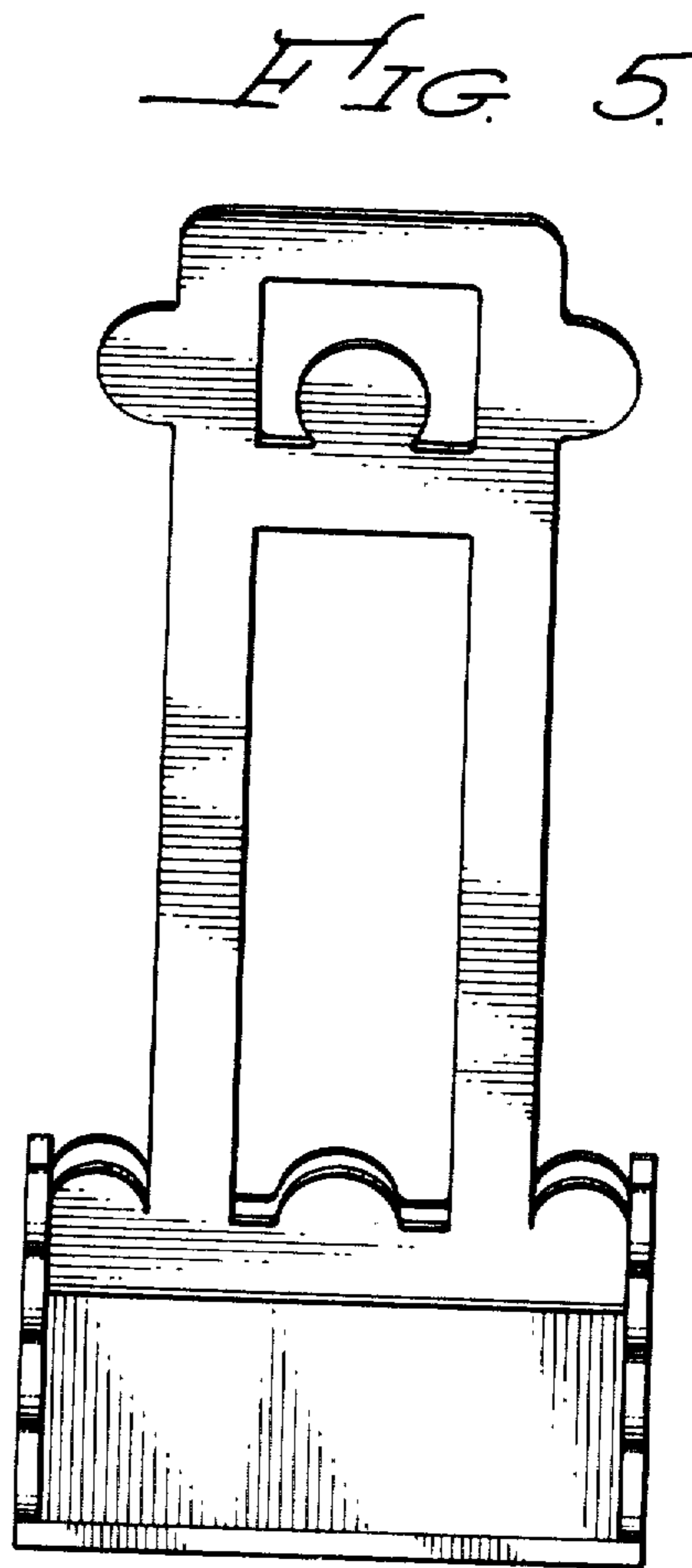

FIG. 5.

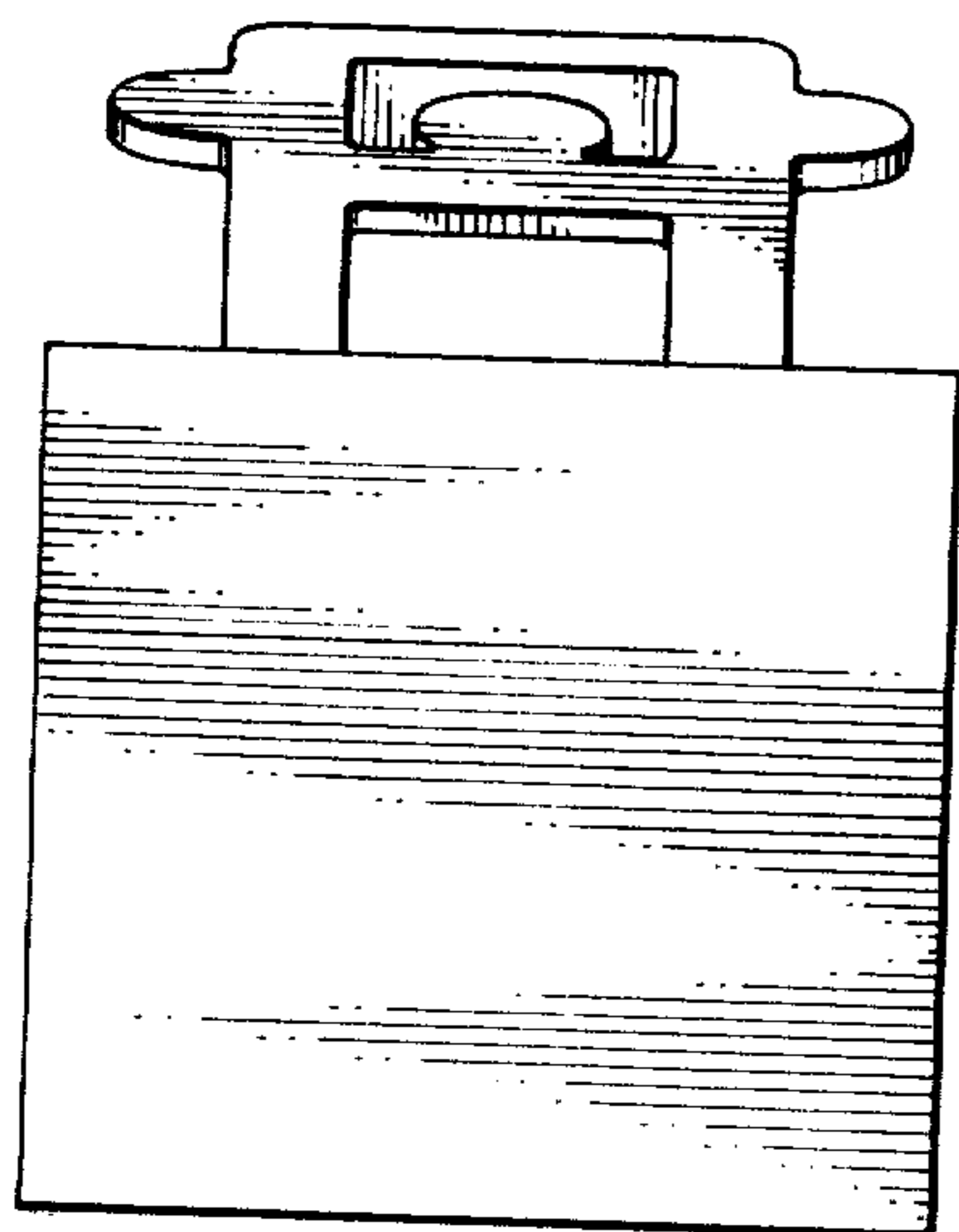

FIG. 6.