

[54] **COMBINED AIR MUFFLER AND FILTER**
[75] Inventor: **Michael Schenker**, Warren, N.J.
[73] Assignee: **Coilhose Pneumatics, Inc.**,
Middlesex, N.J.
[**] Term: **14 Years**
[21] Appl. No.: **65,592**
[22] Filed: **Aug. 10, 1979**
[51] Int. Cl. **D12-16**
[52] U.S. Cl. **D12/194**
[58] Field of Search **D12/194; D23/149;**
181/230, 282; 55/310, 313

[56] **References Cited**
U.S. PATENT DOCUMENTS
D. 220,165 3/1971 Trainor D12/194
3,783,590 1/1974 Allen 181/230
4,219,100 8/1980 Wyse 181/230
OTHER PUBLICATIONS
Bulletin No. 925, Arrow Sintered Products Co., 1975, p.

1, "Super Quiet Flow" Silencers/Mufflers, center right side of page.
Bulletin No. 925, Arrow Sintered Products Co., 1975, p. 3, Pneumatic In-Line Filter, top right side of page.
Compressed Air Magazine, 8/79, p. 32, Vyon Silencers, top left side of page.
Primary Examiner—James M. Gandy
Attorney, Agent, or Firm—Lerner, David, Littenberg & Samuel

[57] **CLAIM**
The ornamental design for a combined air muffler and filter, substantially as shown and described.

DESCRIPTION
FIG. 1 is a perspective view of a combined air muffler and filter showing my new design;
FIG. 2 is a top plan view, the bottom plan view is a mirror image thereof;
FIG. 3 is a right elevational view, the left elevational view is a mirror image thereof;
FIG. 4 is a front elevational view; and
FIG. 5 is a rear elevational view.

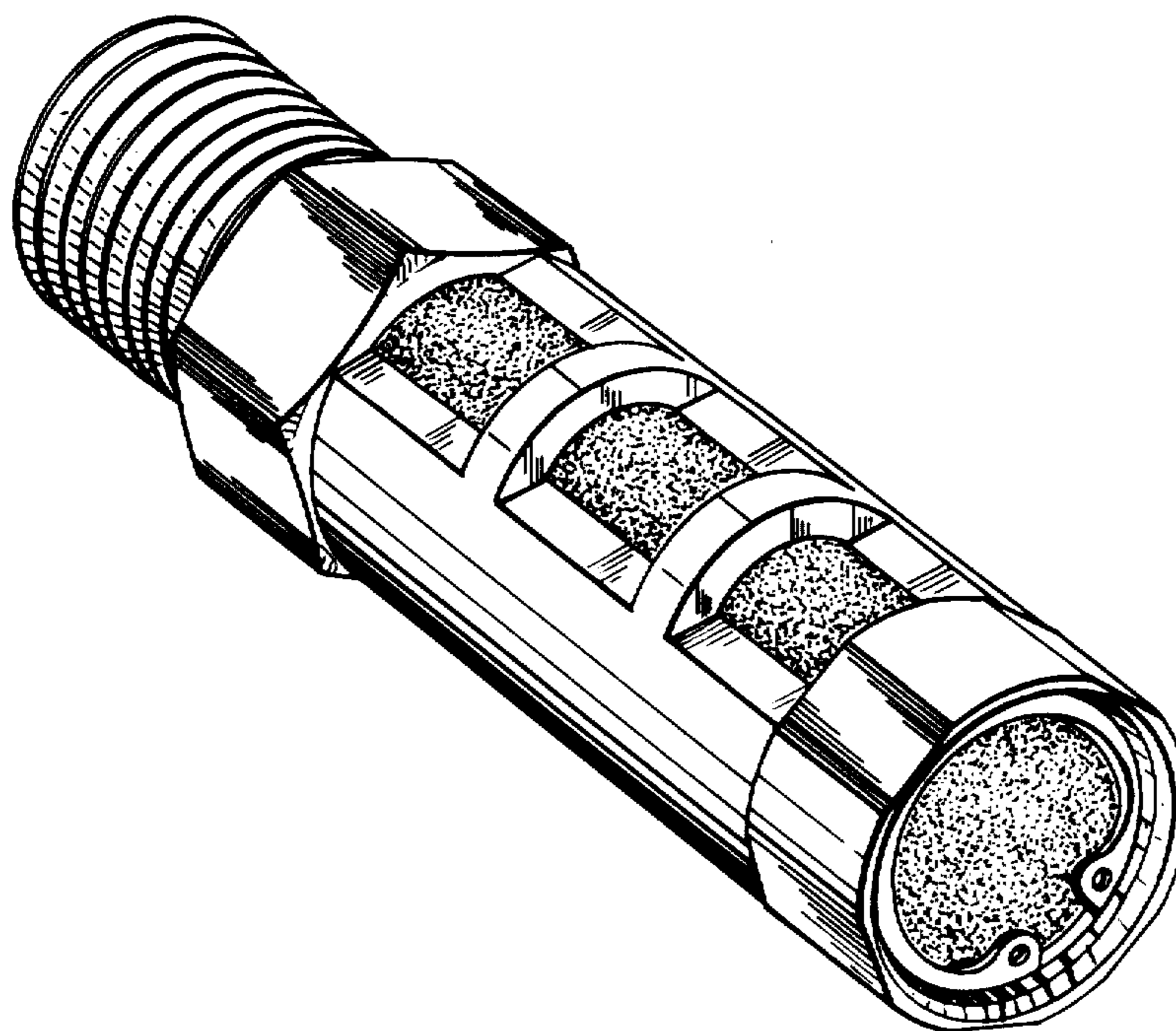

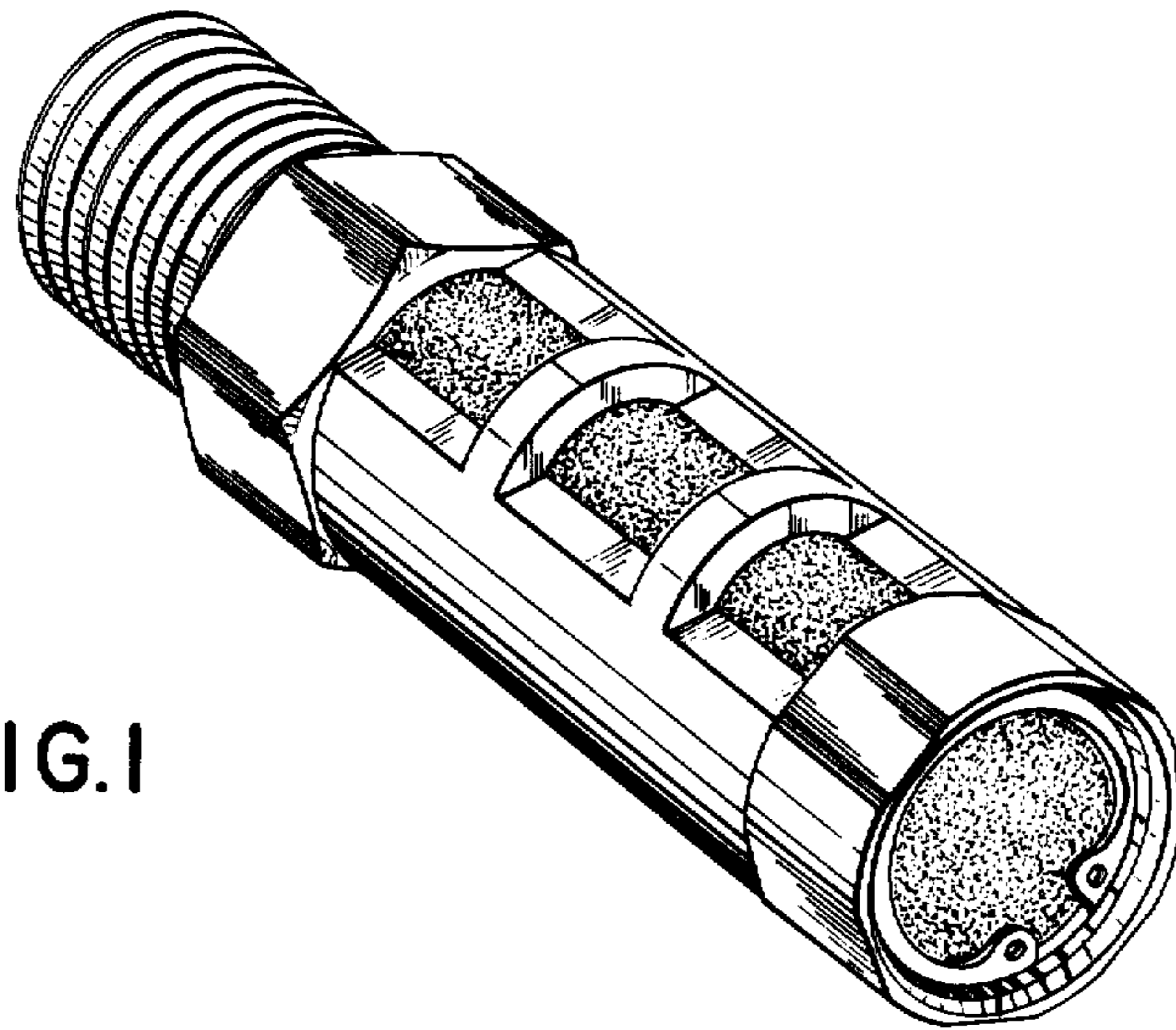

FIG. 1

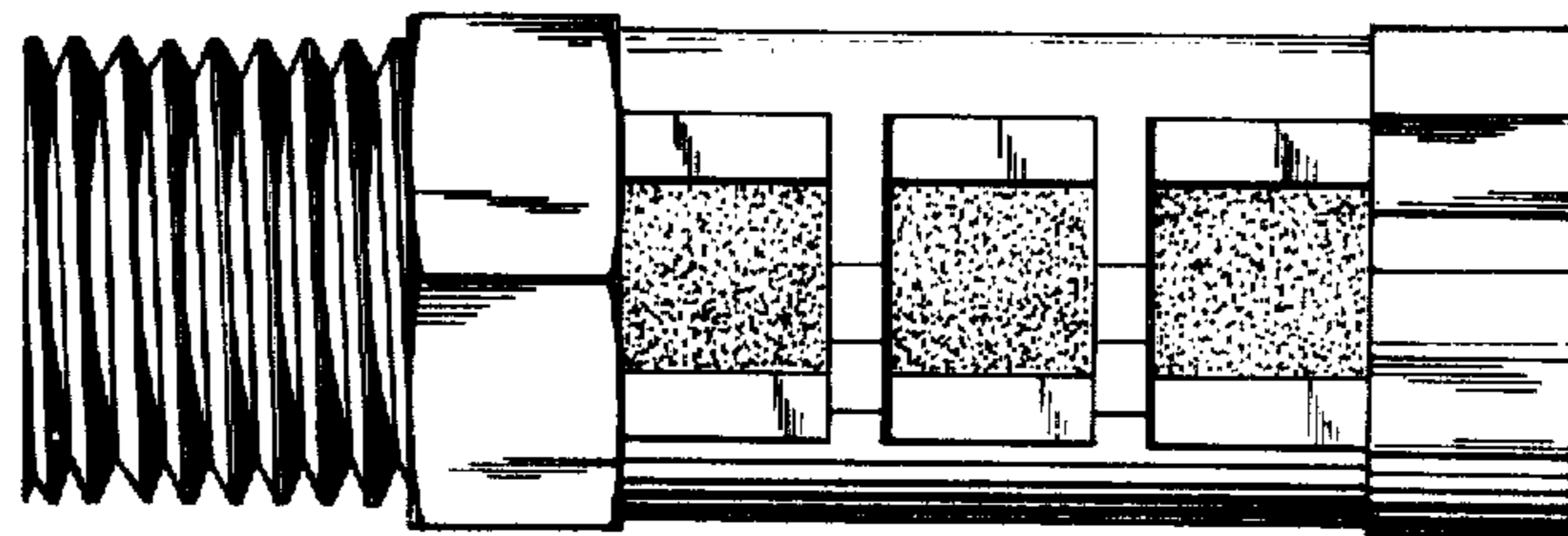

FIG. 2

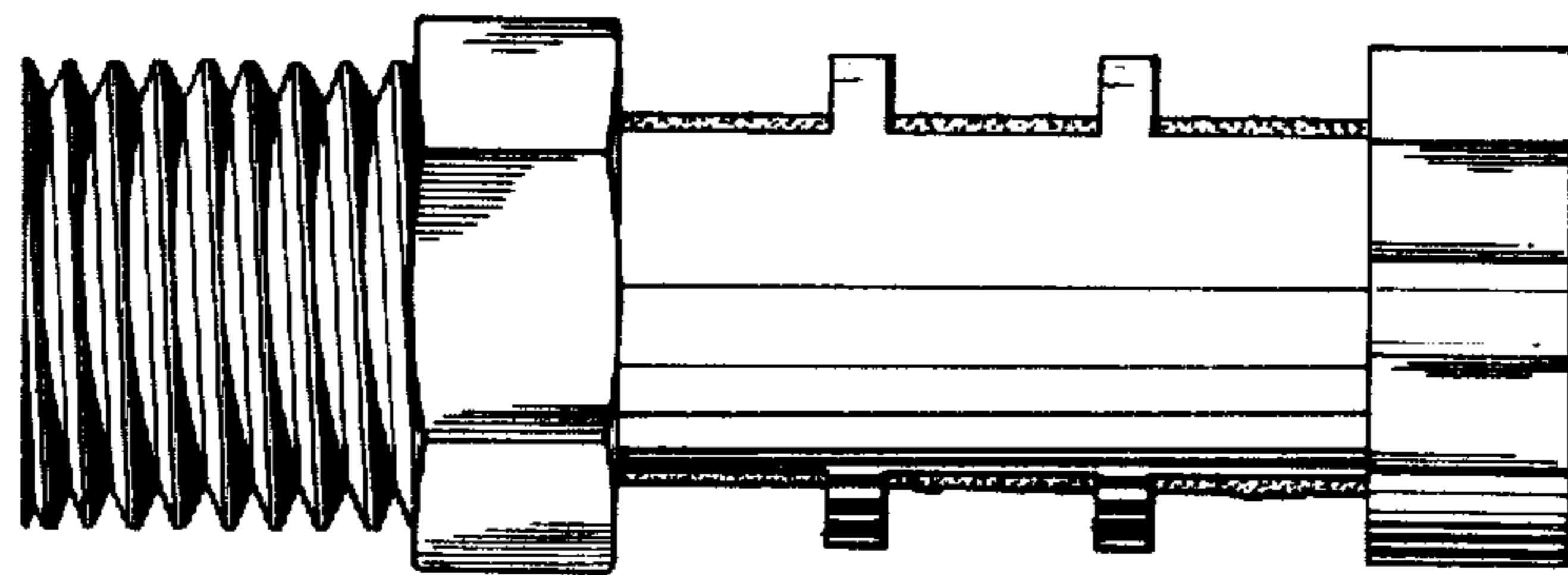

FIG. 3

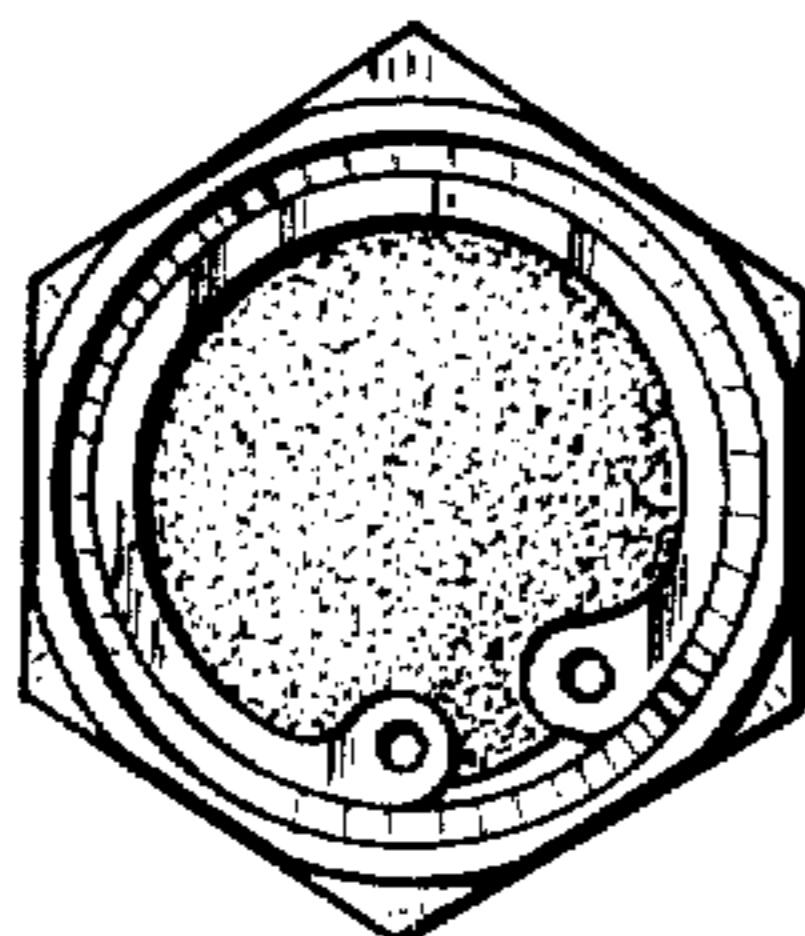

FIG. 4

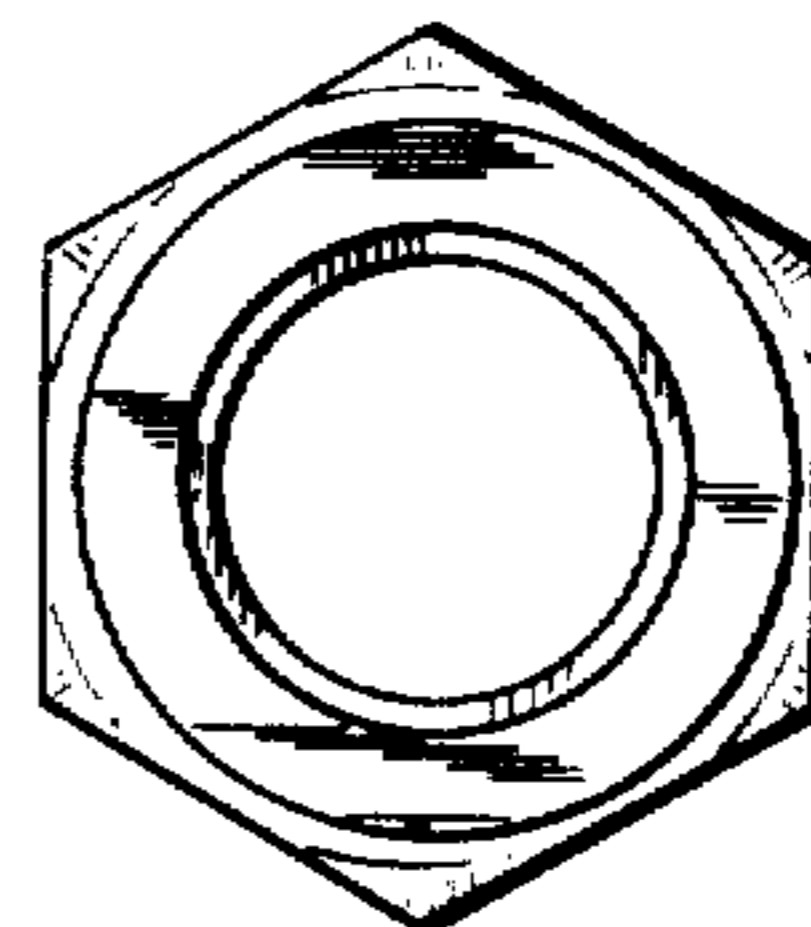

FIG. 5