

[54] COMBINED TOY VEHICLE AND STEERING DEVICE THEREFOR

[75] Inventors: John Birdsall, Los Angeles, Calif.; Edward B. Bretschger, Cos Cob, Conn.; Fred Adickes, El Segundo; Ronald Hellenthal, Torrance, both of Calif.

[73] Assignee: Louis Marx & Co., Inc., Stamford, Conn.

[**] Term: 14 Years

[21] Appl. No.: 876,798

[22] Filed: Feb. 10, 1978

[51] Int. Cl. D21-01

[52] U.S. Cl. D21/142; D21/143

[58] Field of Search D21/59, 109, 142, 143, D21/166, 90; 46/1 B, 1 J, 1 K, 107

[56] References Cited

U.S. PATENT DOCUMENTS

- D. 187,660 4/1960 Robbins et al. D21/109
- D. 207,014 2/1967 Ryan et al. D21/143
- D. 234,263 2/1975 Sugihara D21/90

OTHER PUBLICATIONS

Playthings, 5-1977, p. 65, "Evel Knievel Toy Caravan".

Primary Examiner—Charles A. Rademaker
Attorney, Agent, or Firm—Blum, Kaplan, Friedman, Silberman & Beran

[57] CLAIM

The ornamental design for a combined toy vehicle and steering device therefor, as shown and described.

DESCRIPTION

FIG. 1 is a front, top, right perspective view of a combined toy vehicle and steering device therefor showing our new design;

FIG. 2 is a left side elevational view thereof;

FIG. 3 is a front elevational view taken along lines 3-3 of FIG. 2;

FIG. 4 is a top plan view taken along lines 4-4 of FIG. 2;

FIG. 5 is a rear elevational view taken along lines 5-5 of FIG. 2; and

FIG. 6 is a bottom plan view thereof taken along lines 6-6 of FIG. 2.

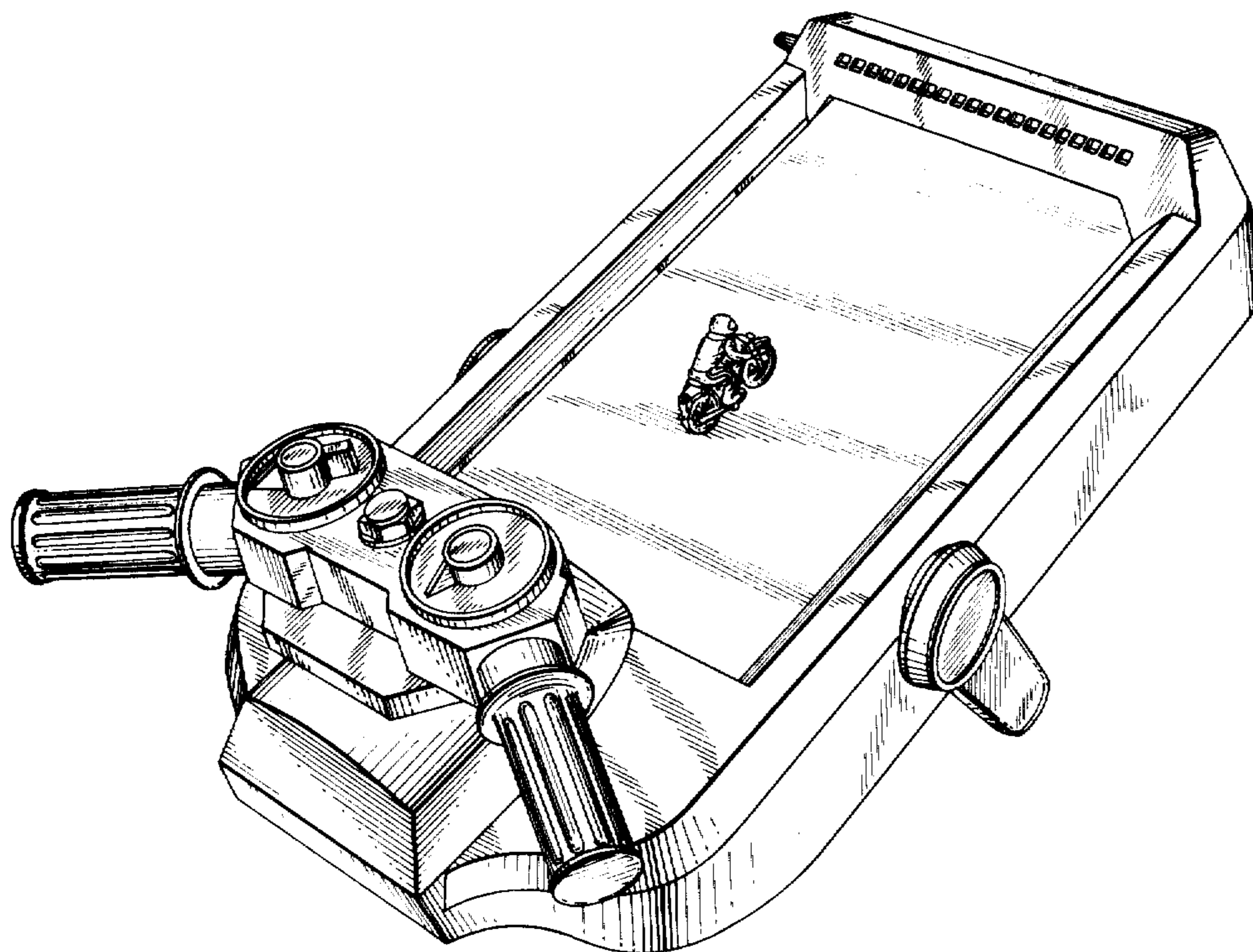

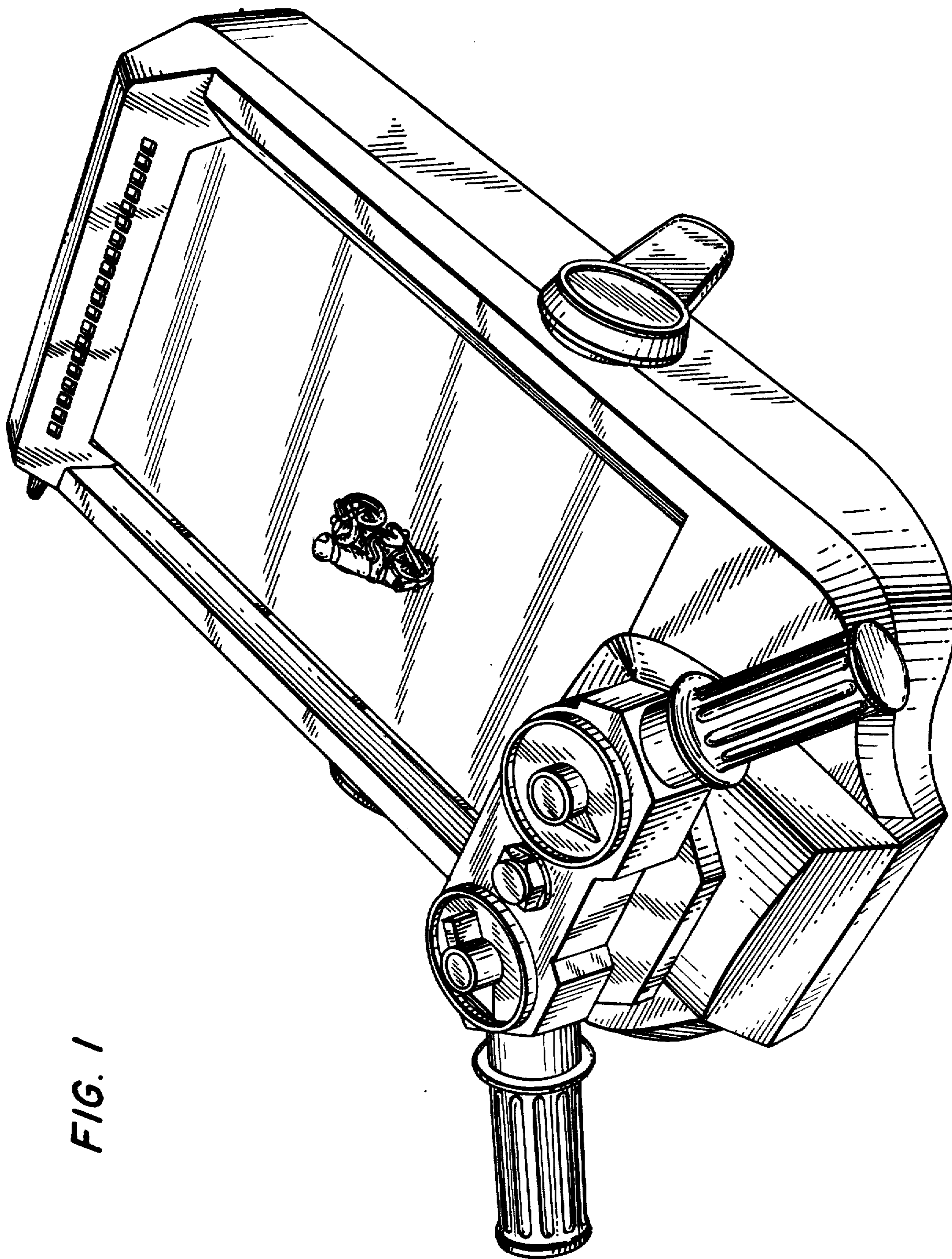
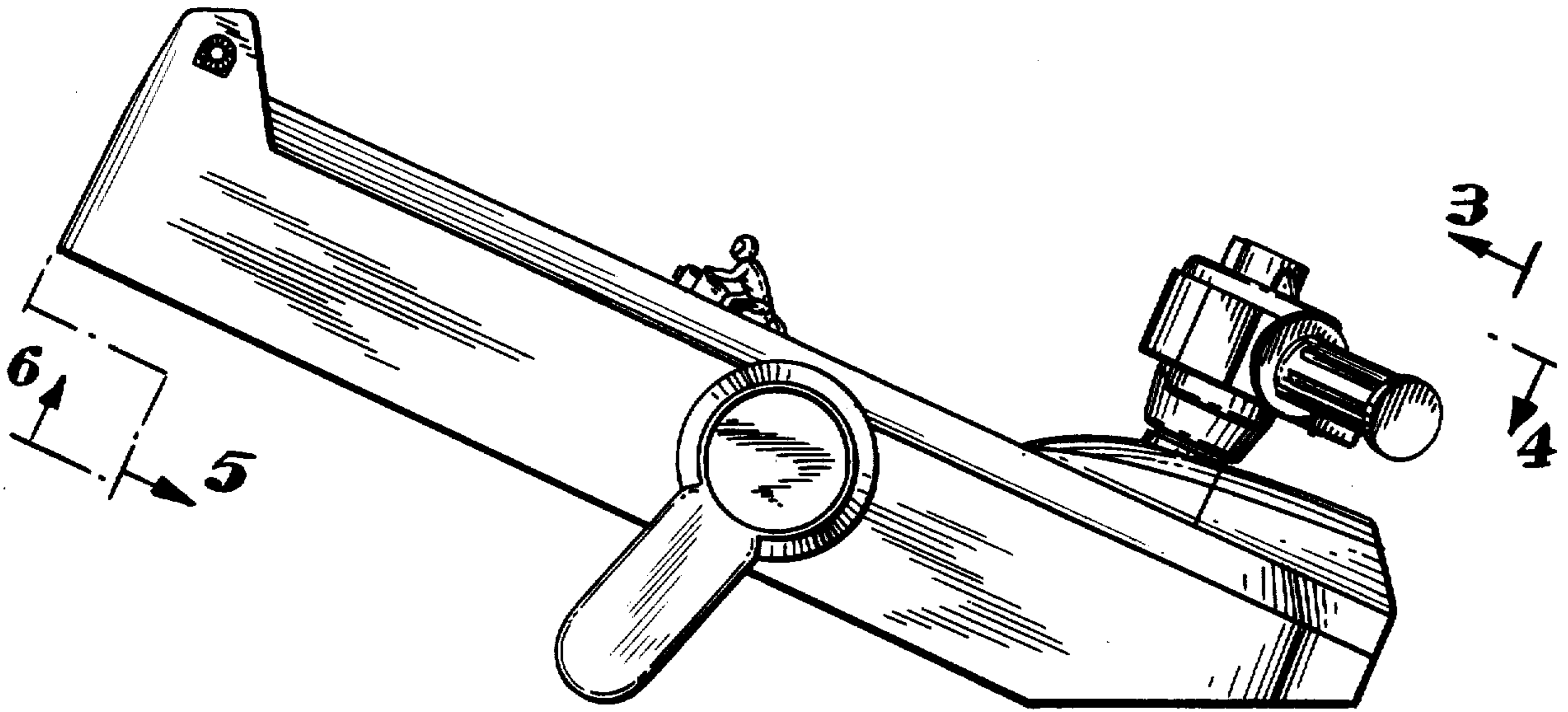

FIG. 1

4
5

FIG. 2



3
6

FIG. 3

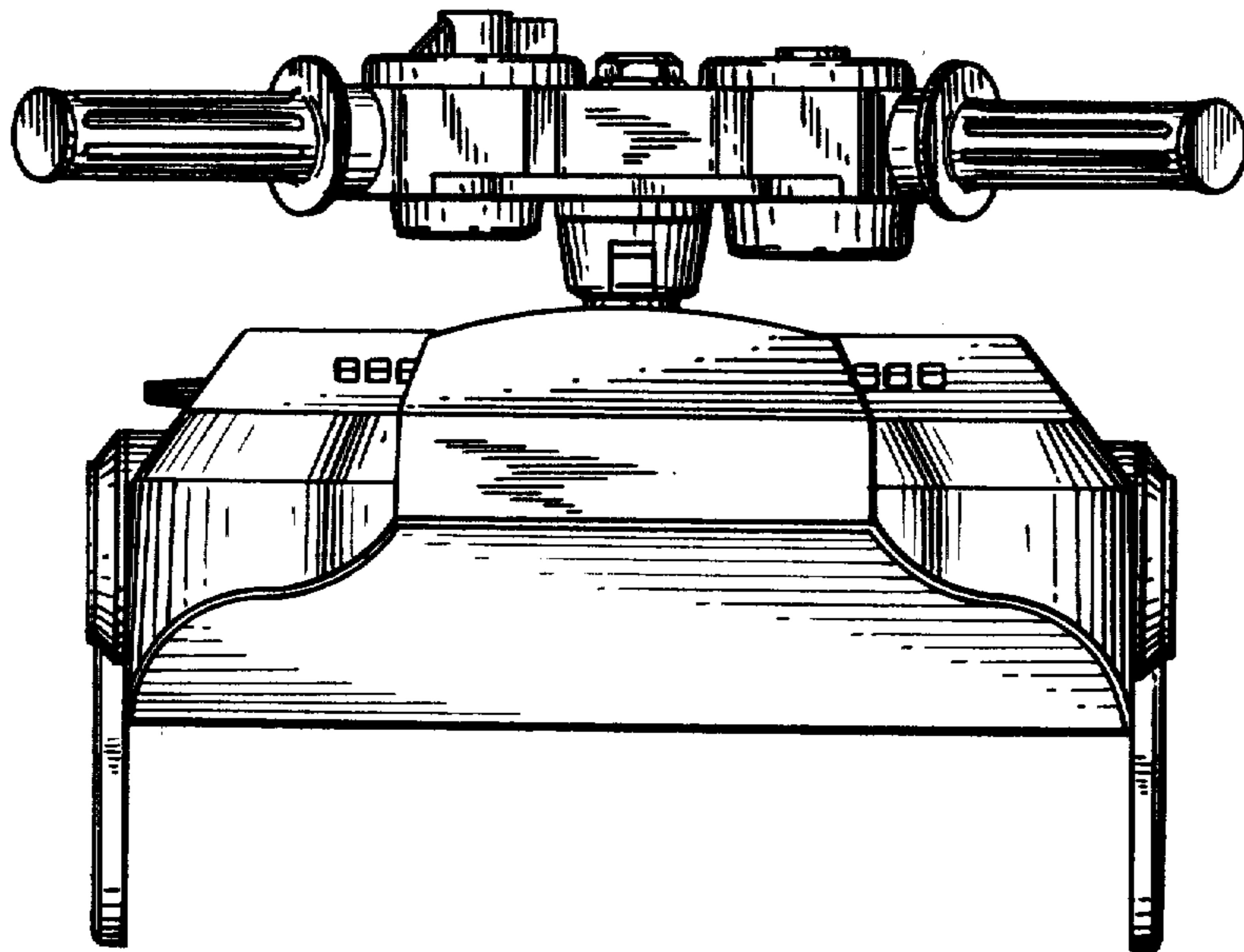

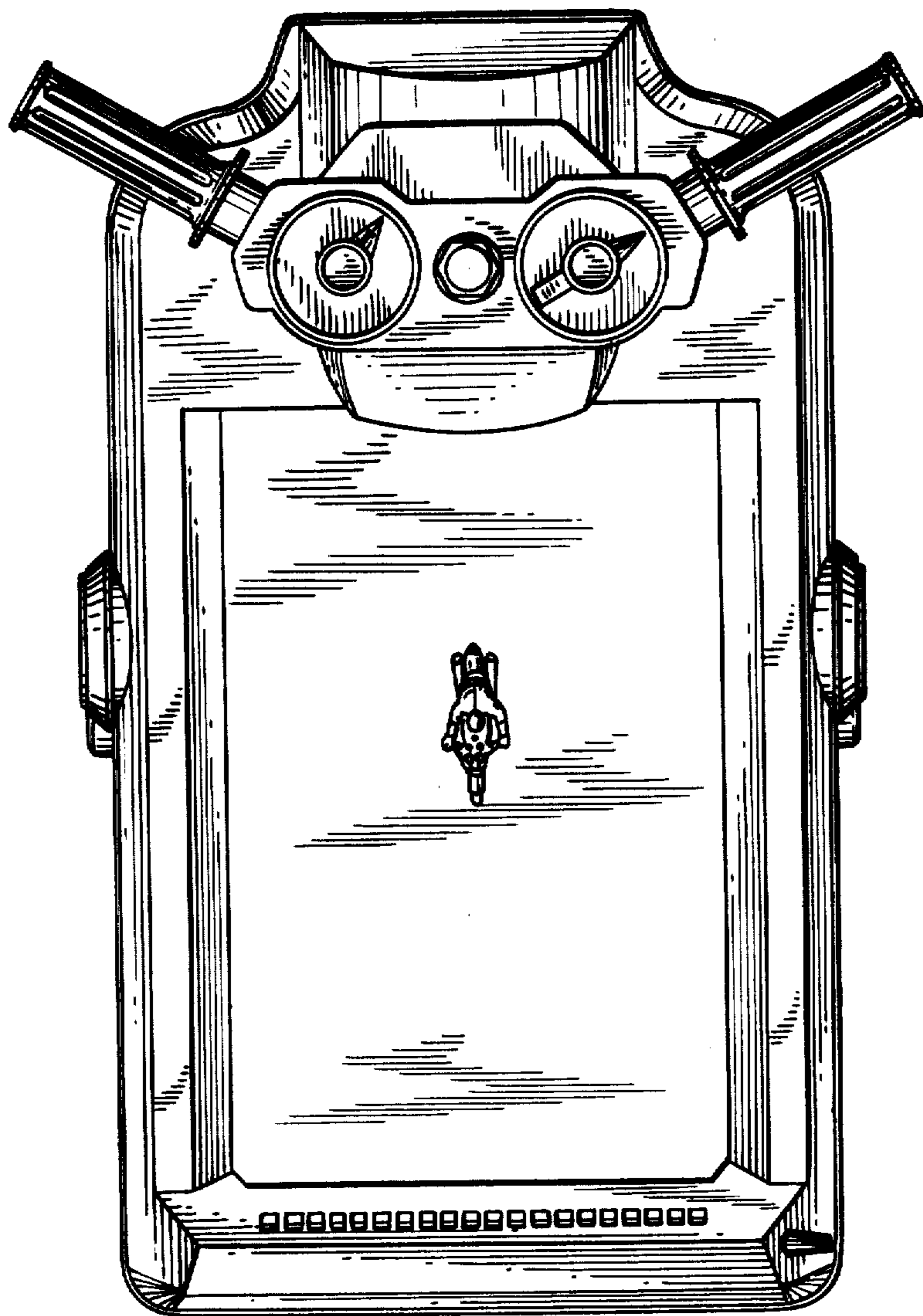

FIG. 4

FIG. 5

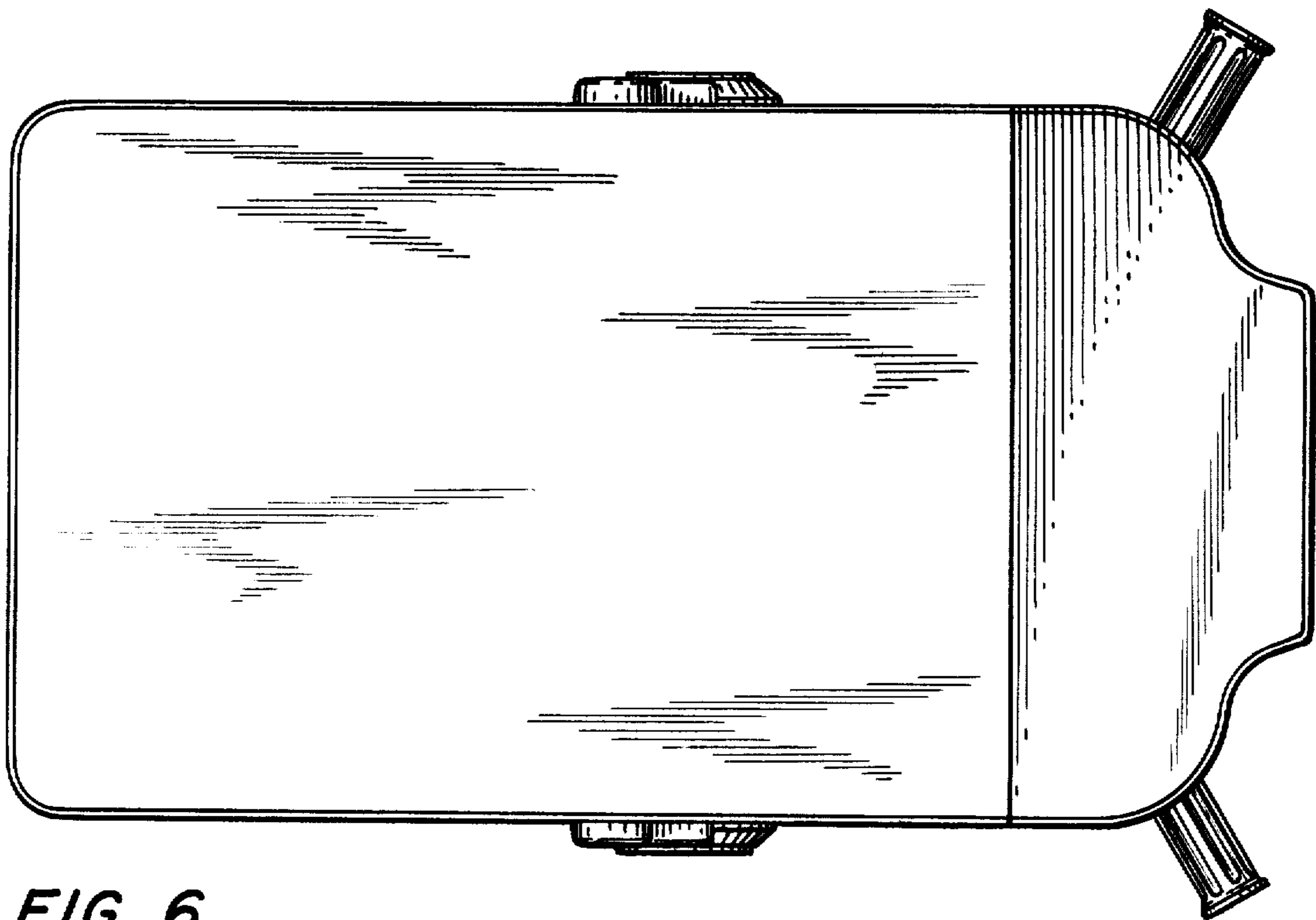
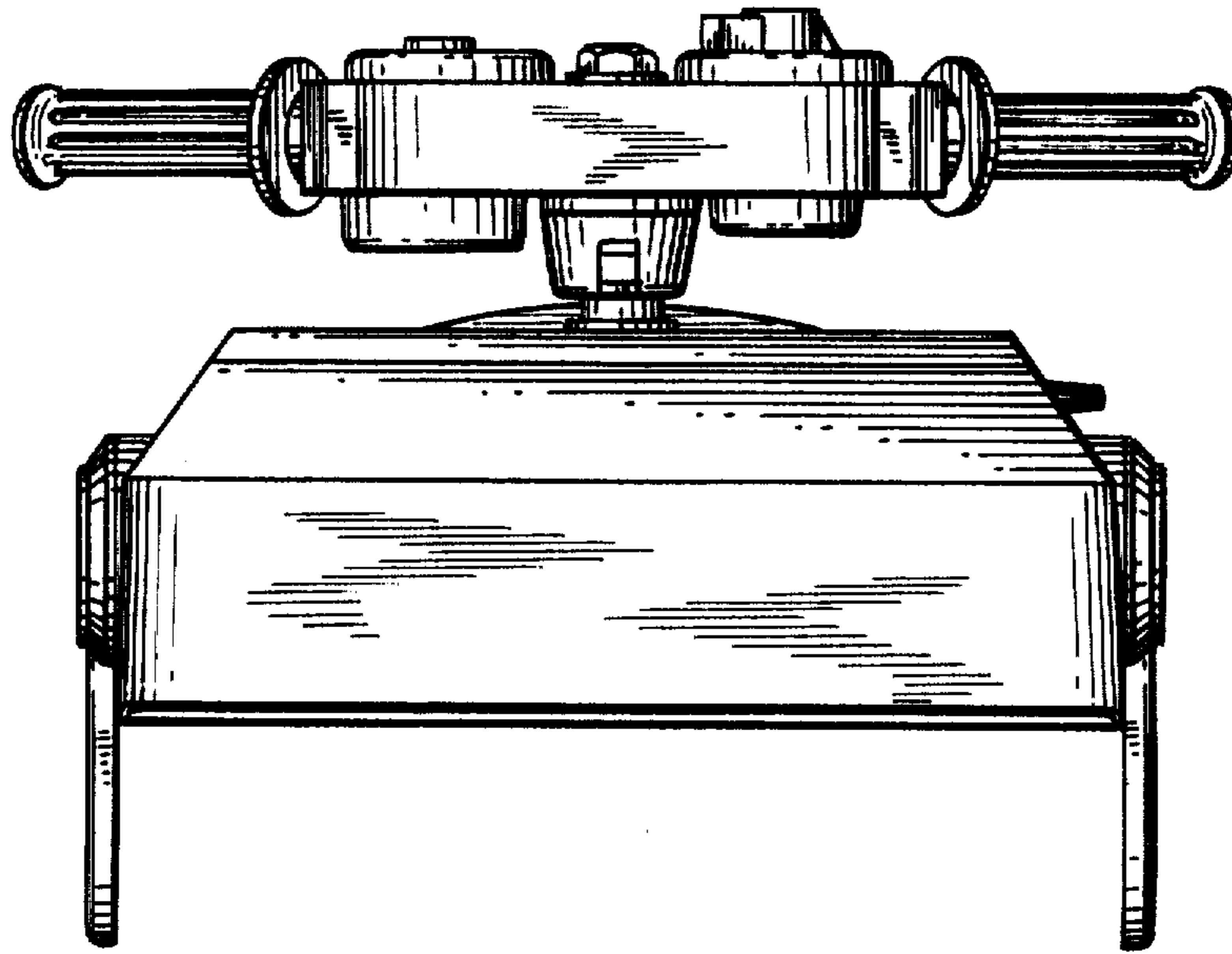

FIG. 6