

[54] RAILROAD RESTAURANT

[76] Inventor: Gary M. Levin, 940 E. 19 St.,
Brooklyn, N.Y. 11230

[**] Term: 14 Years

[21] Appl. No.: 145,049

[22] Filed: Apr. 30, 1980

Related U.S. Application Data

[62] Division of Ser. No. 928,387, Jul. 27, 1978.

[51] Int. Cl. D25-03

[52] U.S. Cl. D25/11; D25/17;
D25/22; D25/23; D25/33; D25/52

[58] Field of Search D25/1, 3, 7, 11, 17,
D25/22, 23, 24, 25, 26, 33, 52; 52/73; D12/101,
102, 103

[56] References Cited

U.S. PATENT DOCUMENTS

D. 115,683	7/1939	Bemis	D25/11
D. 227,356	6/1973	Winter	D25/11
3,673,749	7/1972	Allen	52/73
4,098,036	7/1978	Spöler	52/73 X

OTHER PUBLICATIONS

Interiors, Oct. 1976, p. 88, Victoria Station Restaurant.
Progressive Architecture, Apr. 1977, p. 112, building at
lower right.

Primary Examiner—A. Hugo Word
Attorney, Agent, or Firm—Howard Alan Taishoff

[57] CLAIM

The ornamental design for a railroad restaurant, as
shown and described.

DESCRIPTION

FIG. 1 is a front perspective view of the right side of a
railroad restaurant according to my new design;
FIG. 2 is a front perspective view of the left side of the
railroad restaurant of FIG. 1;
FIG. 3 is a top view of the railroad restaurant of FIG.
1;
FIG. 4 is an elevational view of the right side shown in
FIG. 1;
FIG. 5 is an elevational view of the left side shown in
FIG. 2;
FIG. 6 is an elevational view of the front shown in FIG.
1;
FIG. 7 is an elevational view of the rear of the railroad
restaurant of FIG. 1;

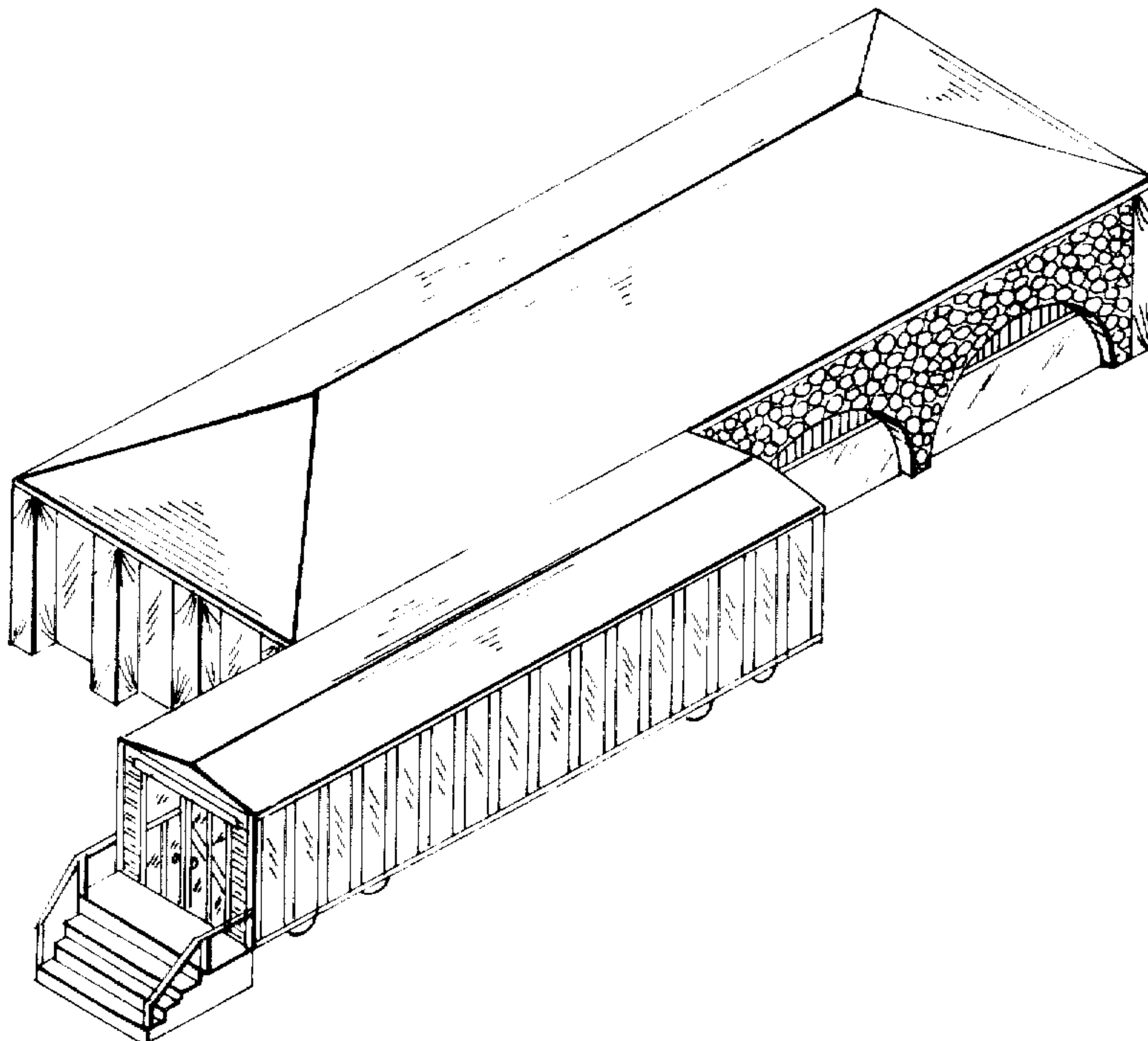

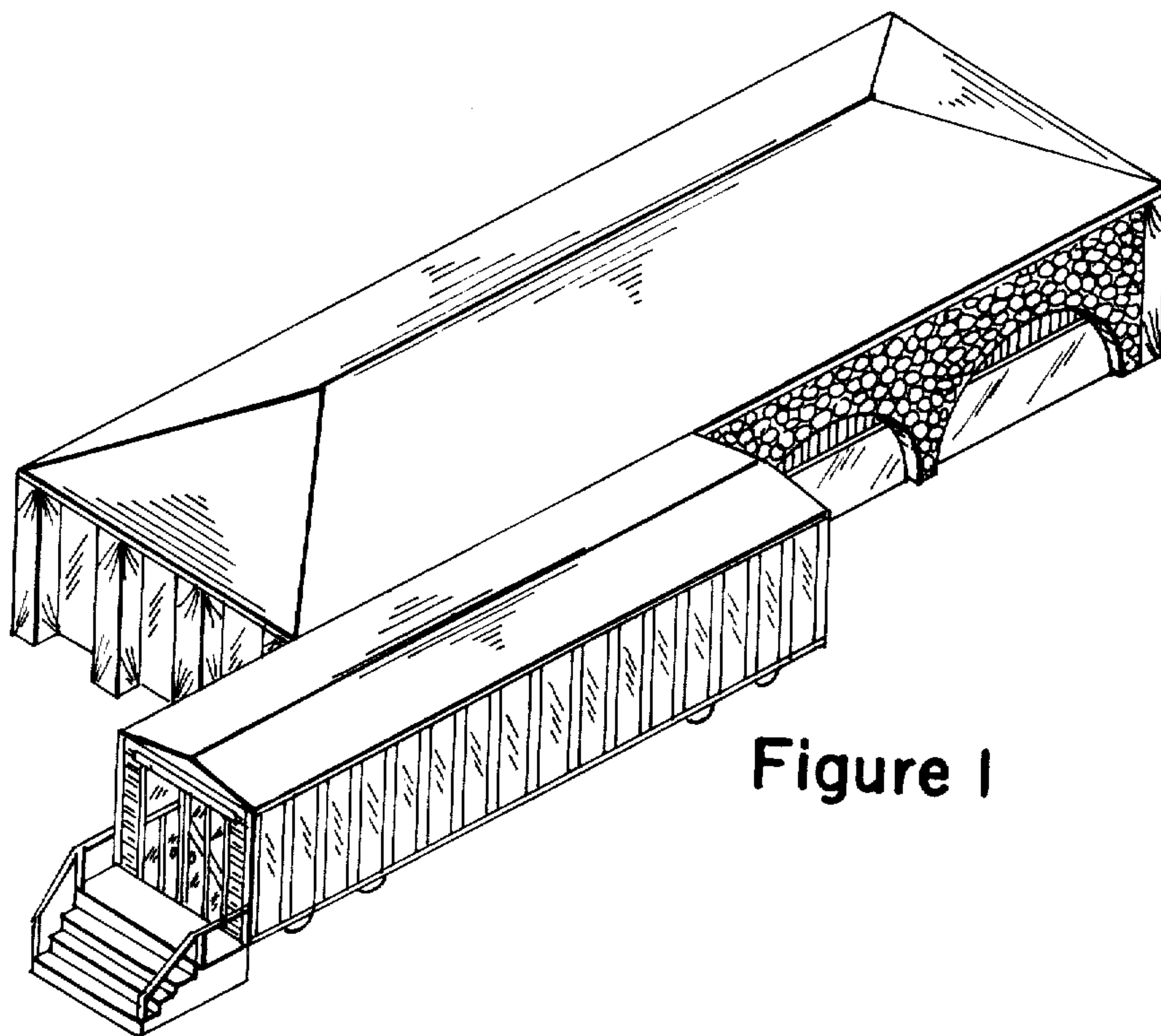

Figure 1

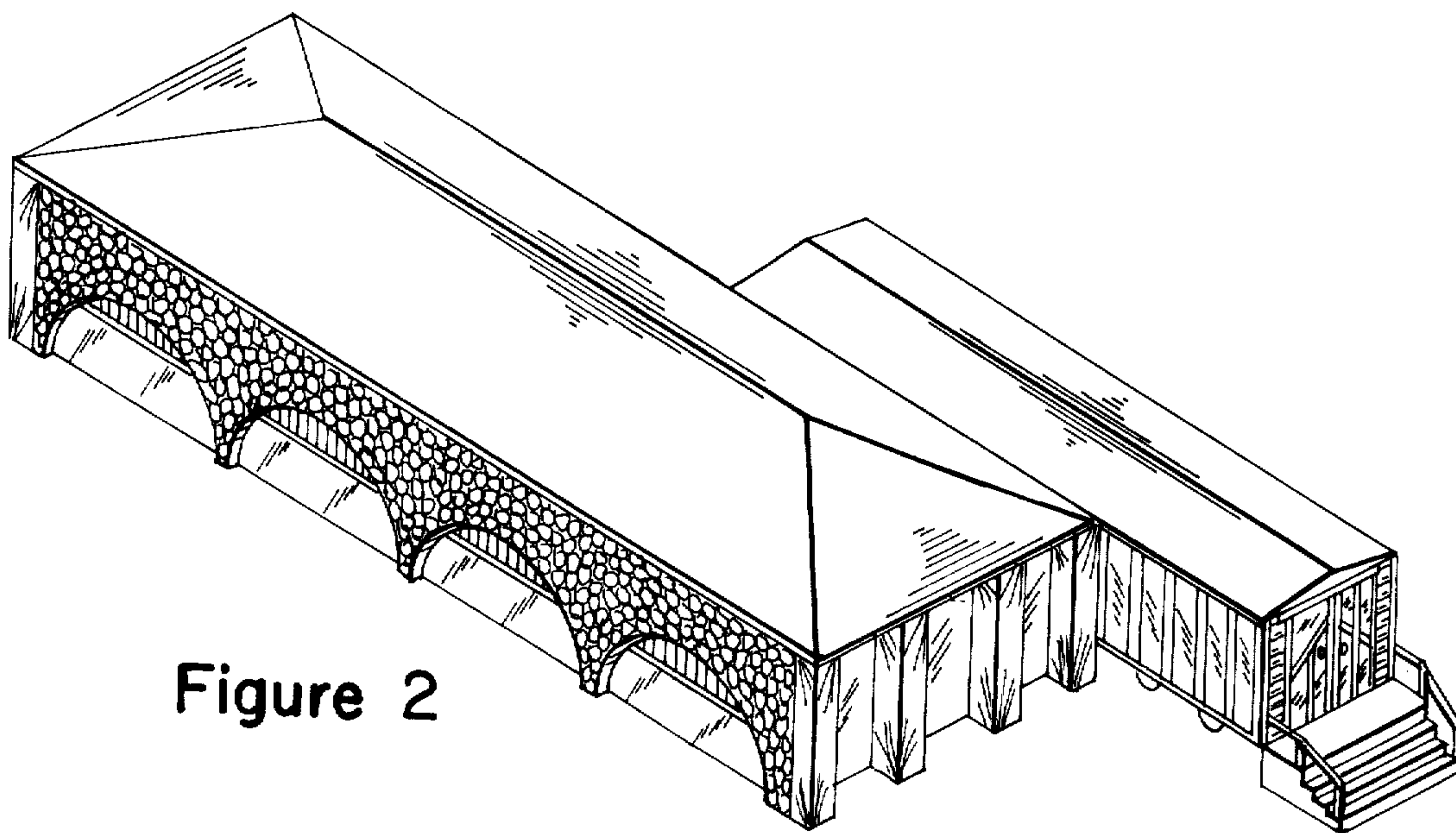

Figure 2

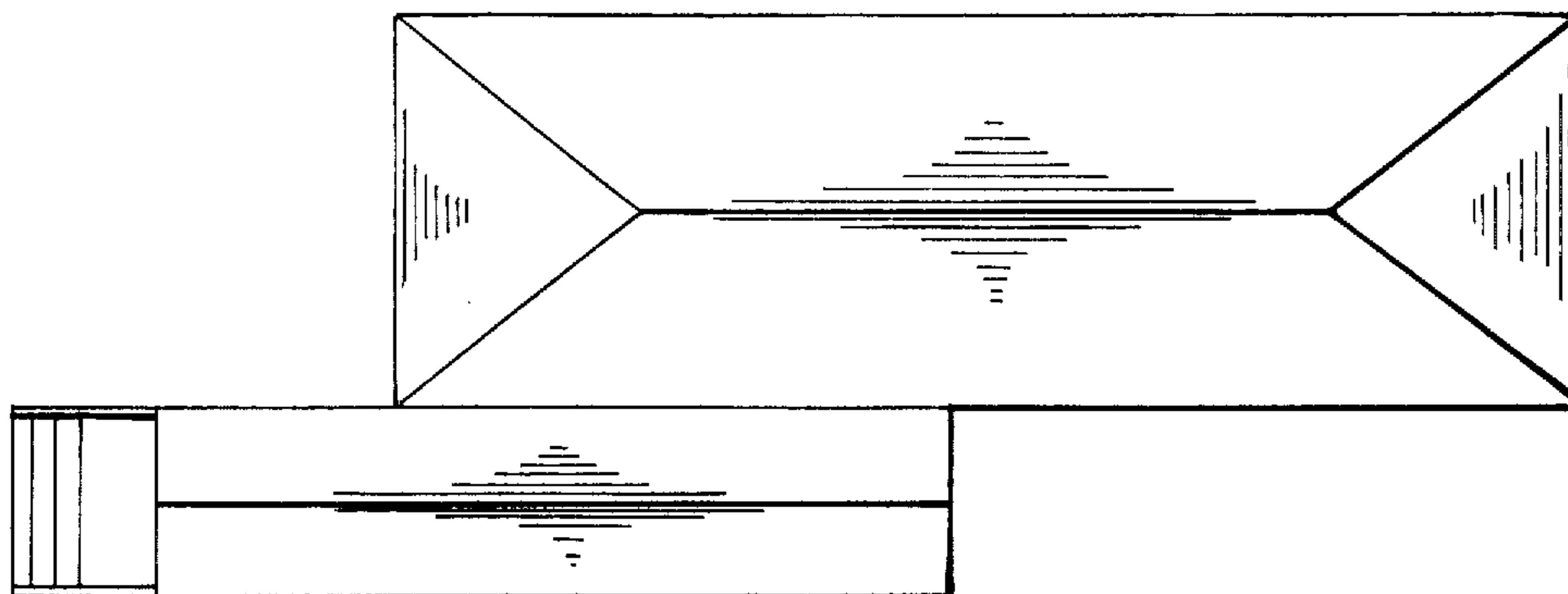

Figure 3

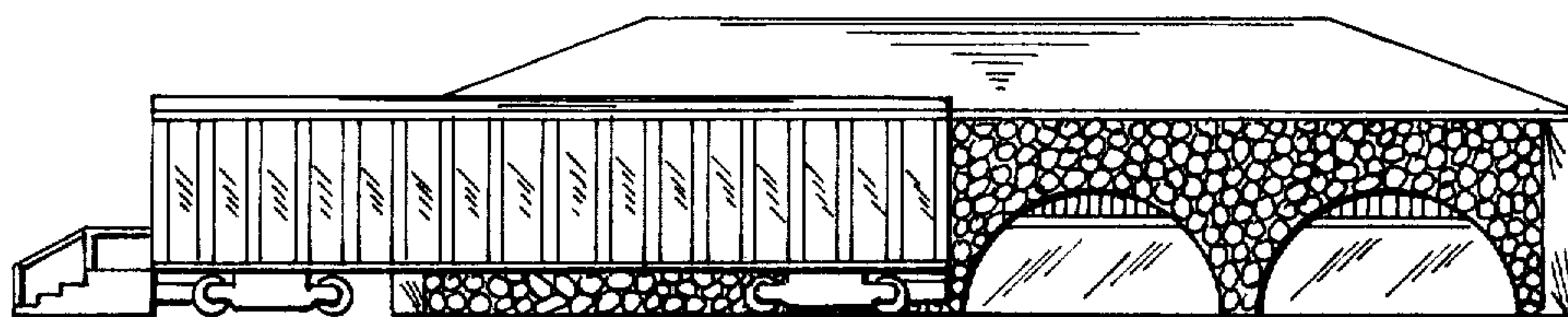

Figure 4

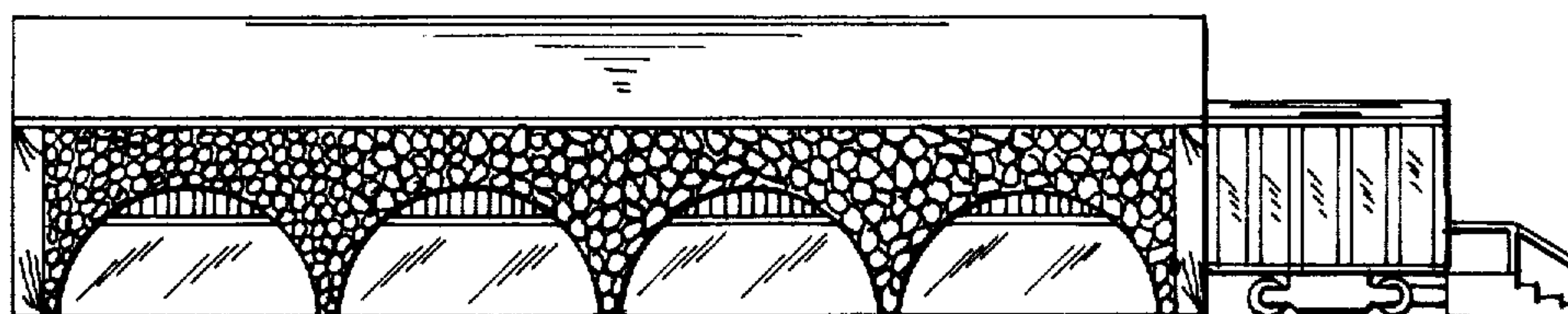

Figure 5

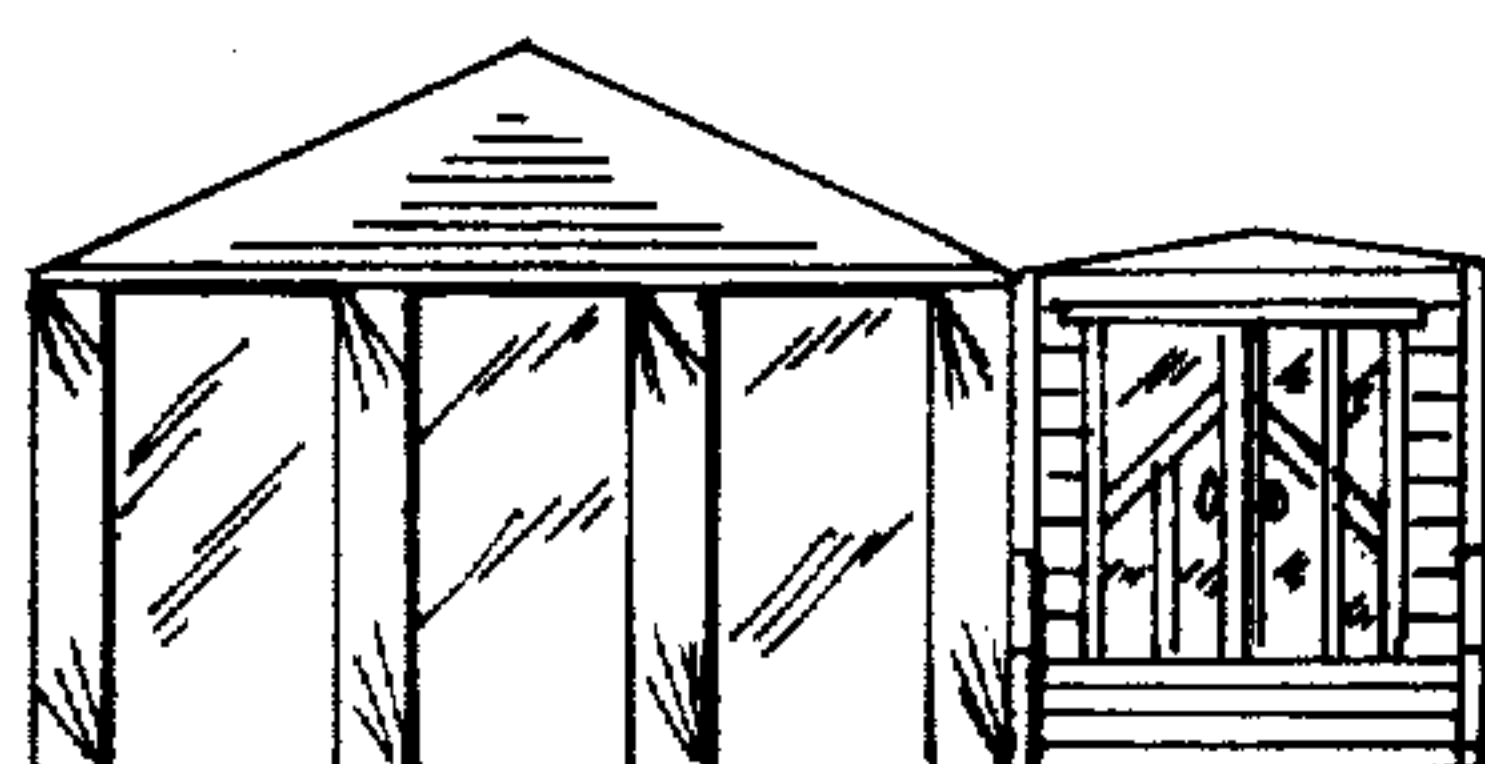

Figure 6

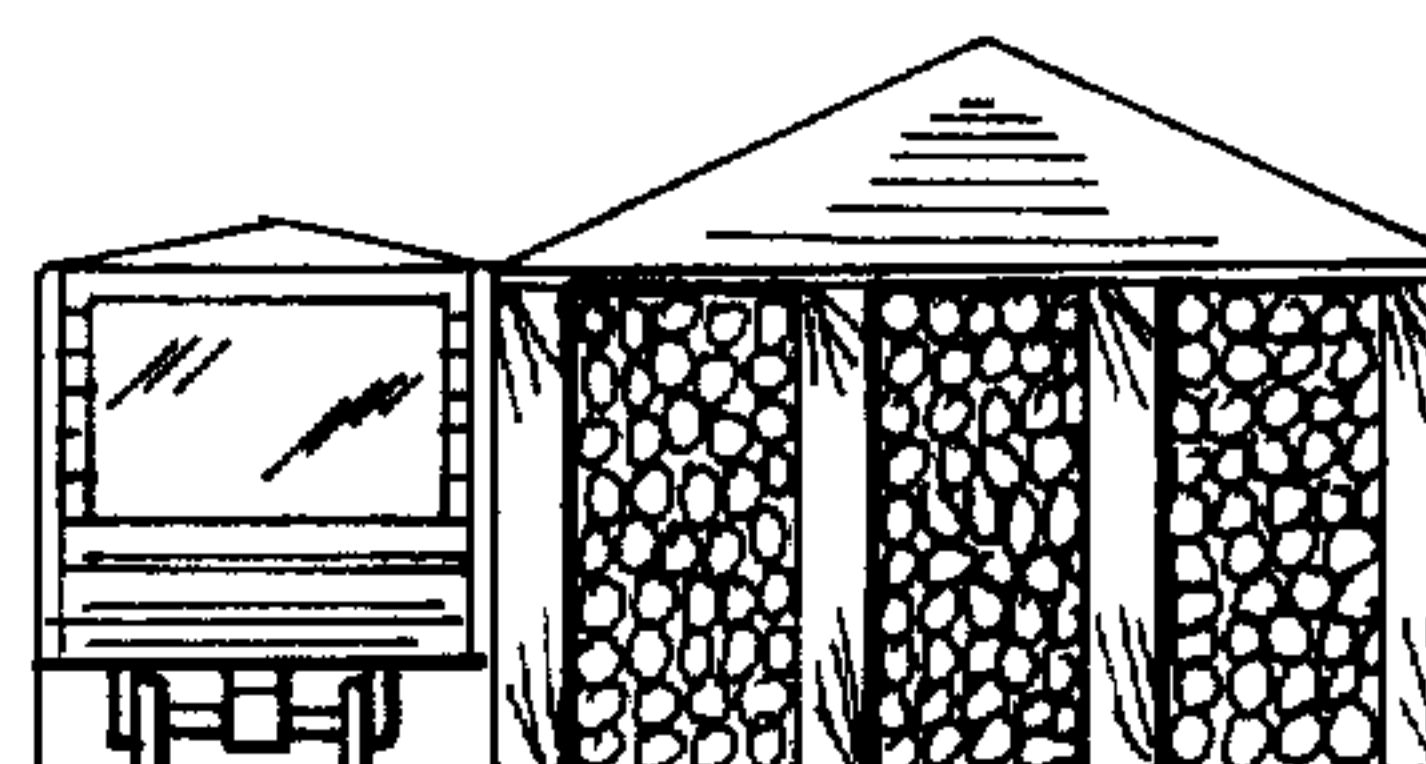

Figure 7