

[54] VEHICLE TRACK SHOE

[75] Inventors: George L. Joseph, Morgan Hill;  
George A. Travinski, San Jose, both  
of Calif.

[73] Assignee: FMC Corporation, San Jose, Calif.

[\*\*] Term: 14 Years

[21] Appl. No.: 955,299

[22] Filed: Oct. 27, 1978

[51] Int. Cl. .... D15-04

[52] U.S. Cl. .... D15/28; D12/7

[58] Field of Search .... D15/24, 28; D12/7;  
305/35 EB, 35 R, 39, 58

[56] References Cited

U.S. PATENT DOCUMENTS

3,721,476 3/1973 Andersson ..... 305/58  
4,139,240 2/1979 Proflo et al. .... 305/39

Primary Examiner—James M. Gandy  
Attorney, Agent, or Firm—A. J. Moore; R. B. Megley

[57] CLAIM

The ornamental design for a vehicle track shoe, as shown and described.

DESCRIPTION

FIG. 1 is a right top perspective view of a vehicle track shoe showing our new design;

FIG. 2 is a right bottom perspective view thereof;

FIG. 3 is an enlarged right side elevational view thereof;

FIG. 4 is an enlarged cross-sectional view thereof taken along line 4-4 in FIG. 1; and

FIG. 5 is an enlarged cross-sectional view thereof taken along lines 5-5 in FIG. 1.

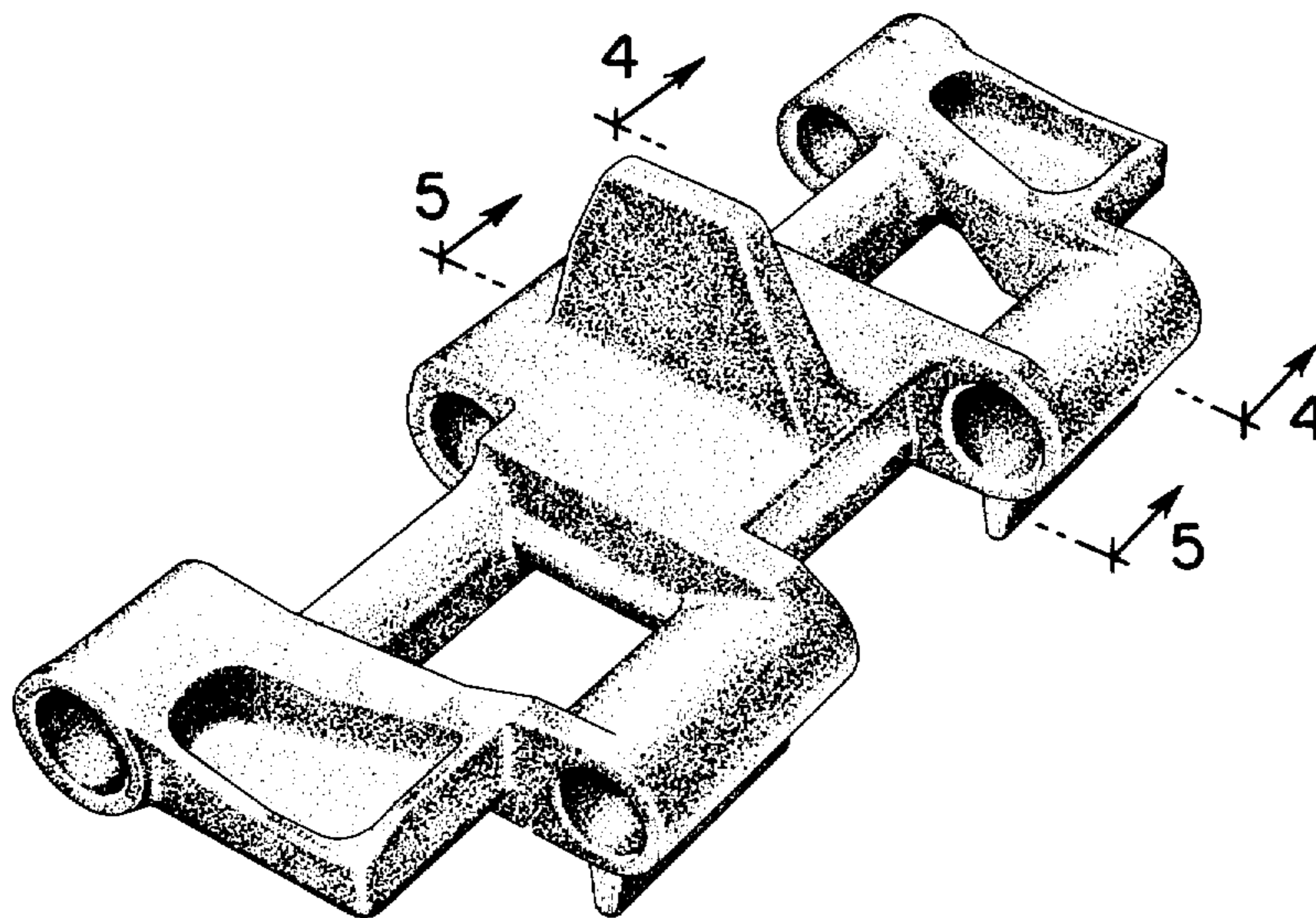

**FIG. 1**

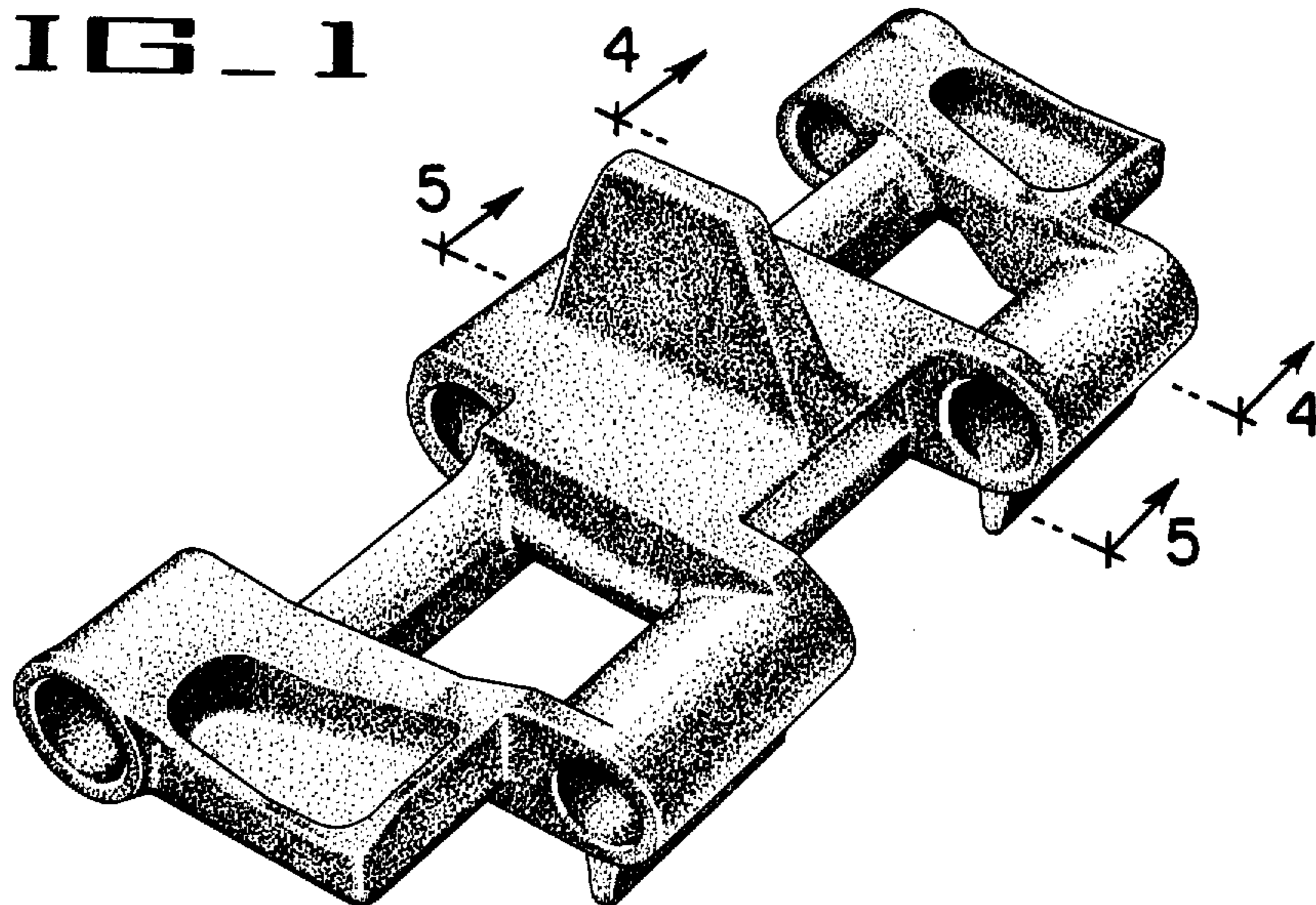

**FIG. 2**

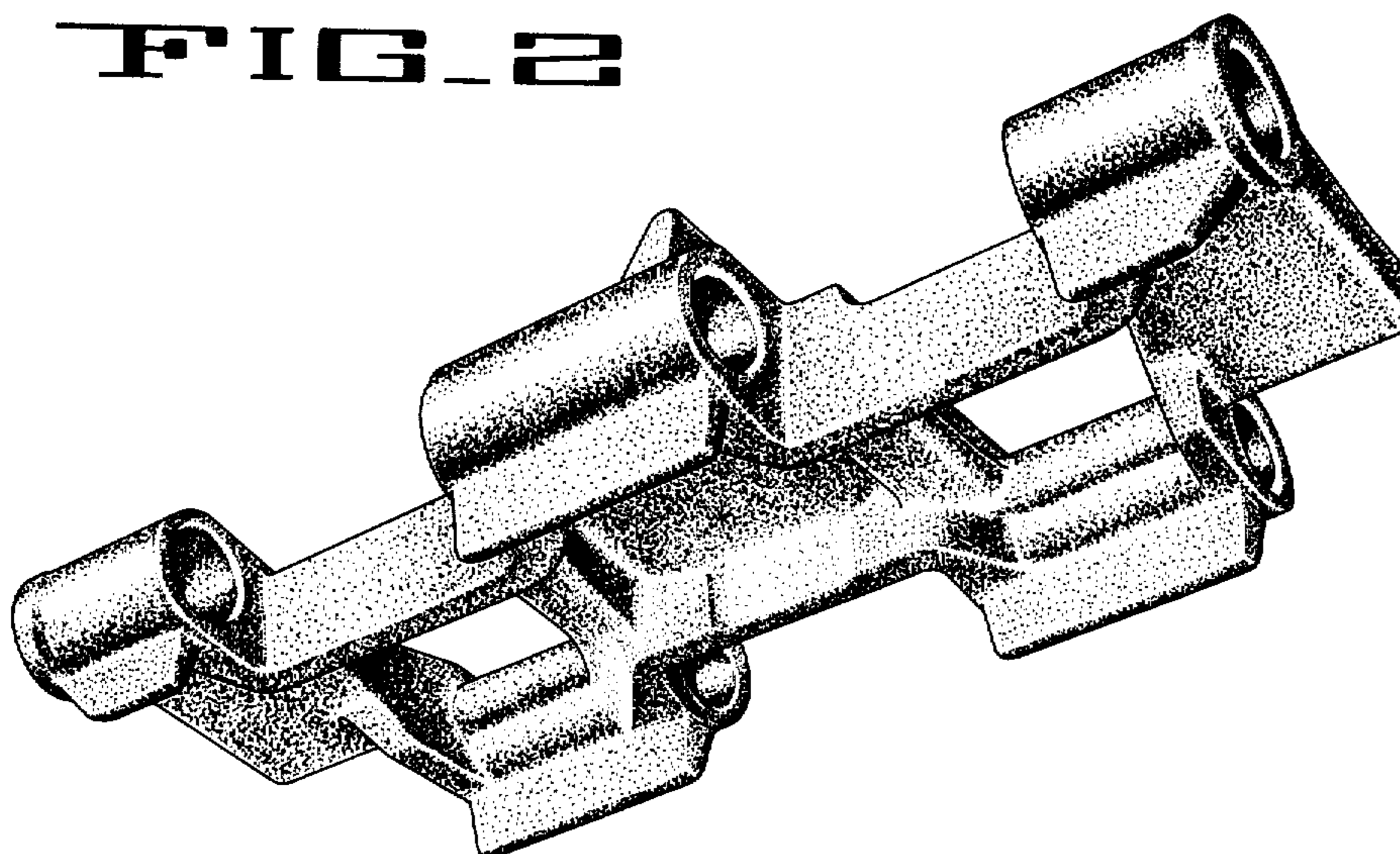

**FIG. 3**

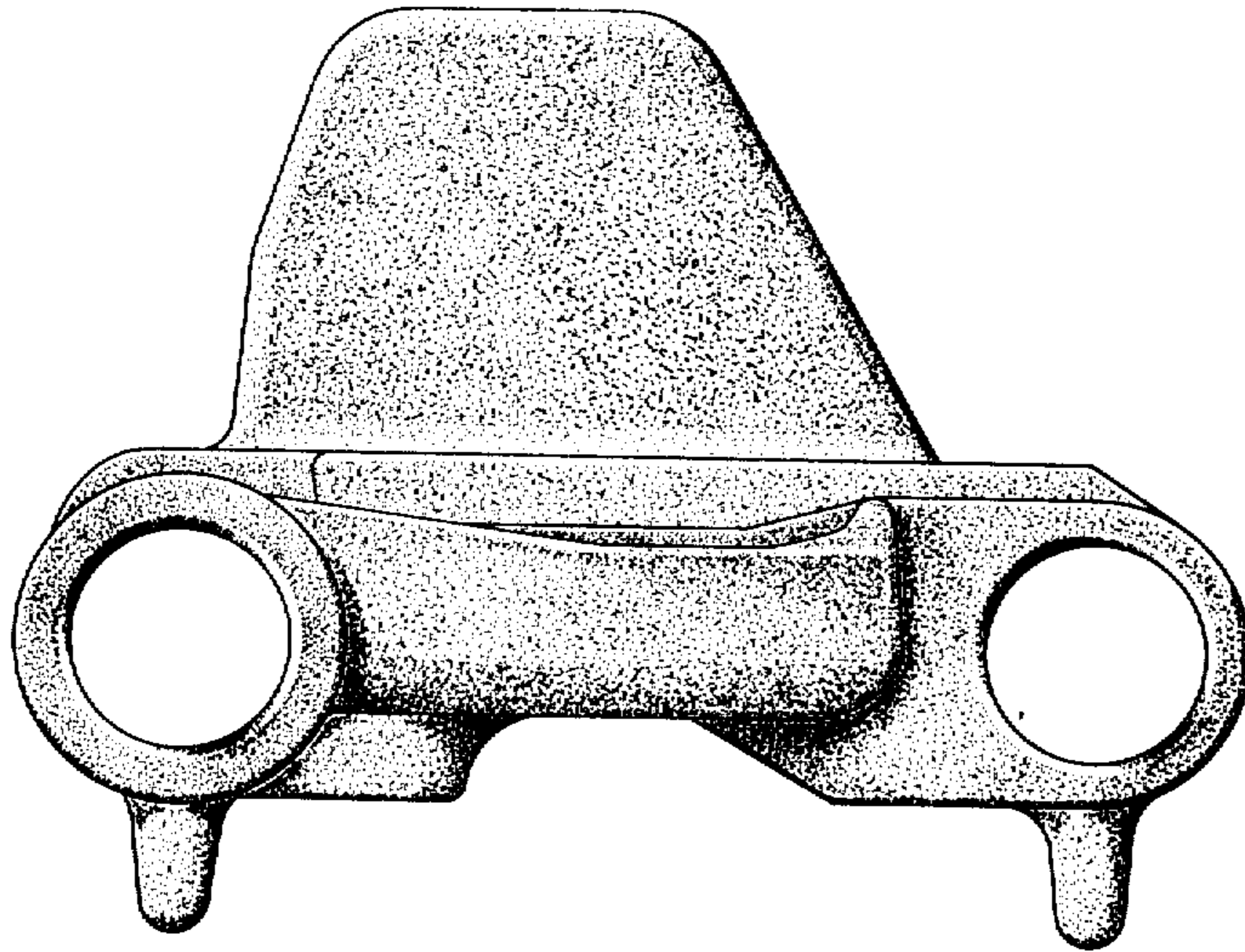

**FIG. 4**

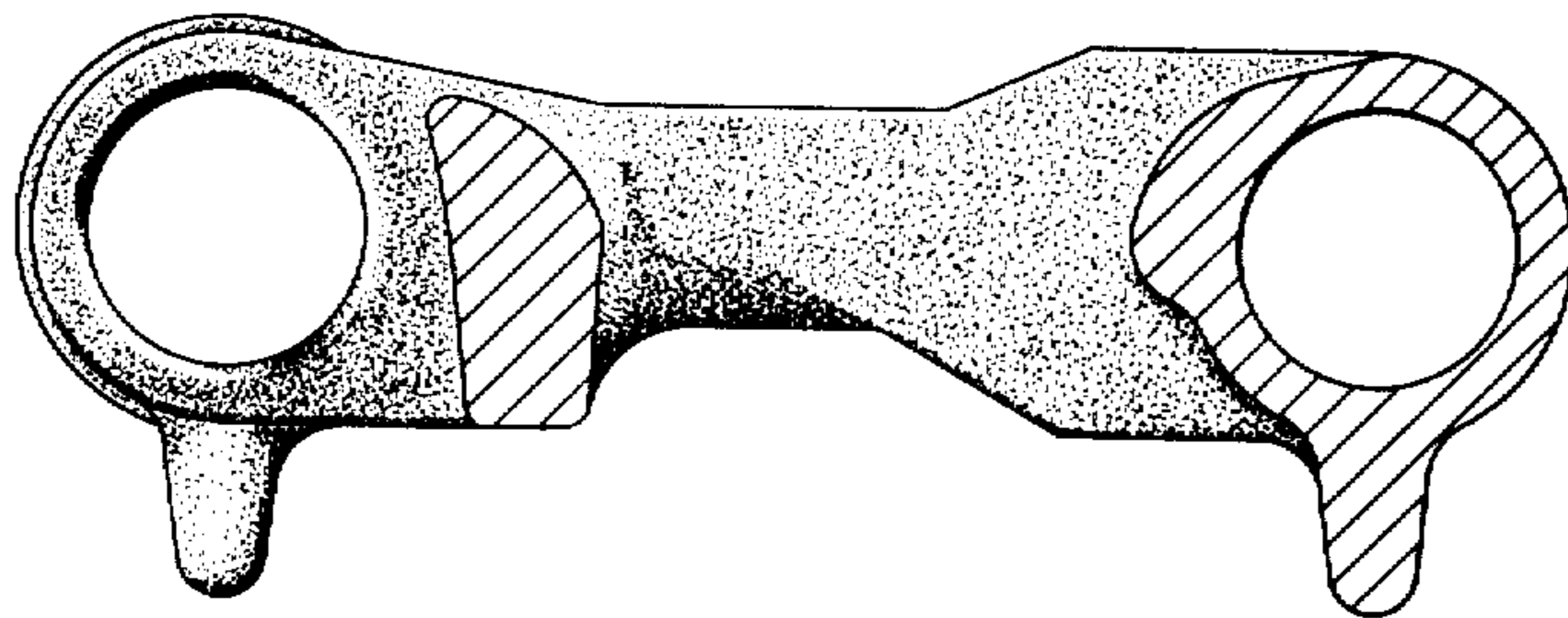

**FIG. 5**

