

- [54] **AIR COMPRESSOR**
- [75] Inventors: **Edwin L. Schwartz; Allen W. Langan,**
both of Los Angeles, Calif.
- [73] Assignee: **Rite Autotronics Corporation,** Los
Angeles, Calif.
- [**] Term: **14 Years**
- [21] Appl. No.: **87,727**
- [22] Filed: **Oct. 24, 1979**
- [51] Int. Cl. **D15-02**
- [52] U.S. Cl. **D15/9**
- [58] Field of Search **D15/7-9;**
417/234, 410, 411

[56] **References Cited**
U.S. PATENT DOCUMENTS

D. 118,165	12/1939	Lotz et al.	D15/9
D. 175,054	6/1955	Wagner et al.	D15/7
D. 197,154	12/1963	Sakaley	D15/7
D. 235,923	7/1975	Faul et al.	D15/9
D. 257,354	10/1980	Fish	D15/9
1,647,818	11/1927	Semak	417/234 X

2,285,218	6/1942	Lotz	417/234
4,187,058	2/1980	Fish	417/234

Primary Examiner—James R. Largen
Attorney, Agent, or Firm—John J. Posta, Jr.

[57] **CLAIM**

The ornamental design for an air compressor, substantially as shown.

DESCRIPTION

FIG. 1 is a perspective view taken from top, front and left end of an air compressor showing our new design; FIG. 2 is a front elevational view thereof; FIG. 3 is a top plan view thereof; FIG. 4 is a right end elevational view thereof; FIG. 5 is a rear elevational view thereof; FIG. 6 is a perspective view similar to FIG. 1, but with the cover in an open position; FIG. 7 is a front elevational view thereof with the cover removed for convenience of illustration; FIG. 8 is a top plan view of FIG. 7; FIG. 9 is a right end elevational view of FIG. 7; FIG. 10 is a left end elevational view of FIG. 7; and FIG. 11 is a rear elevational view of FIG. 7.

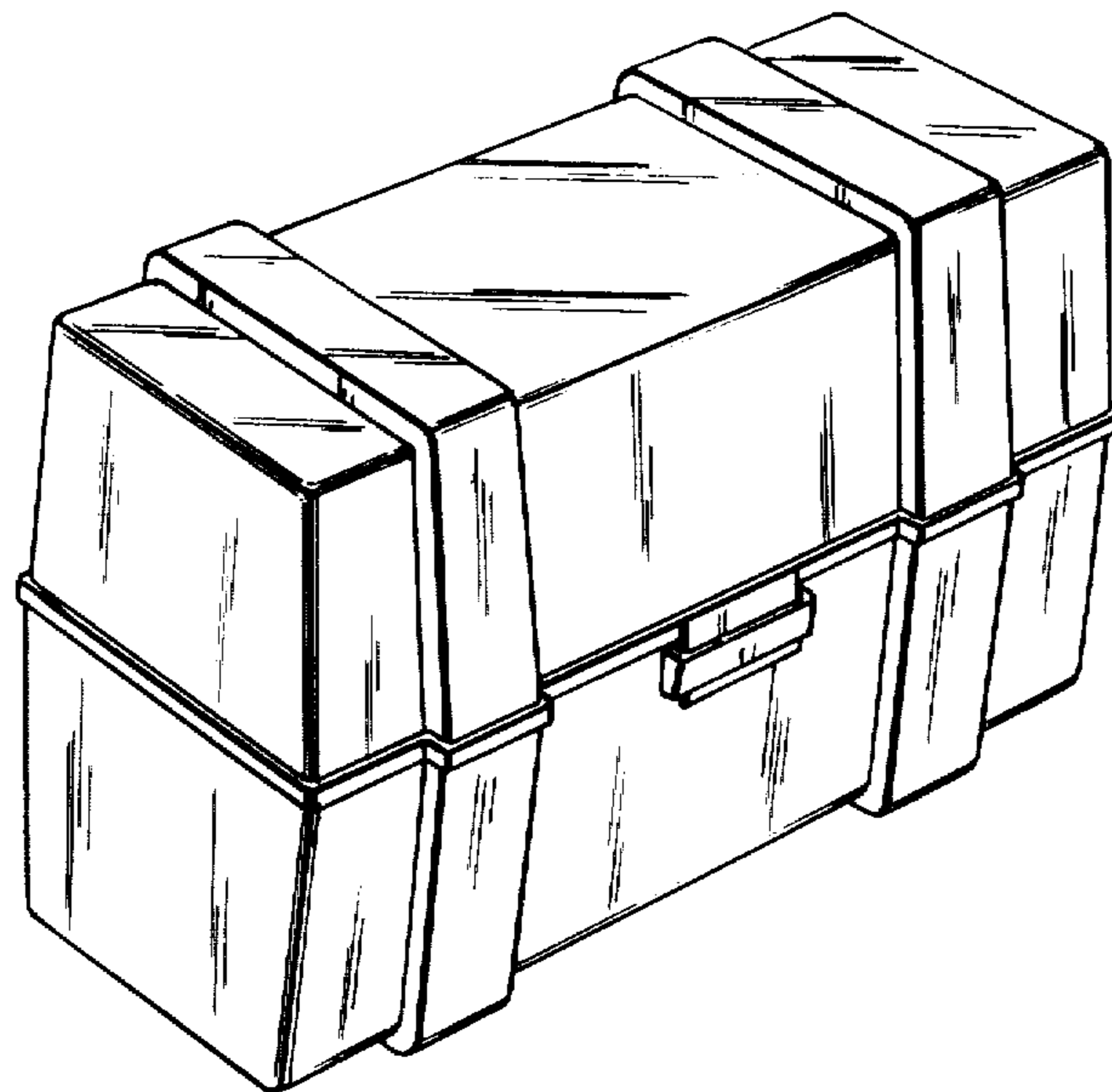

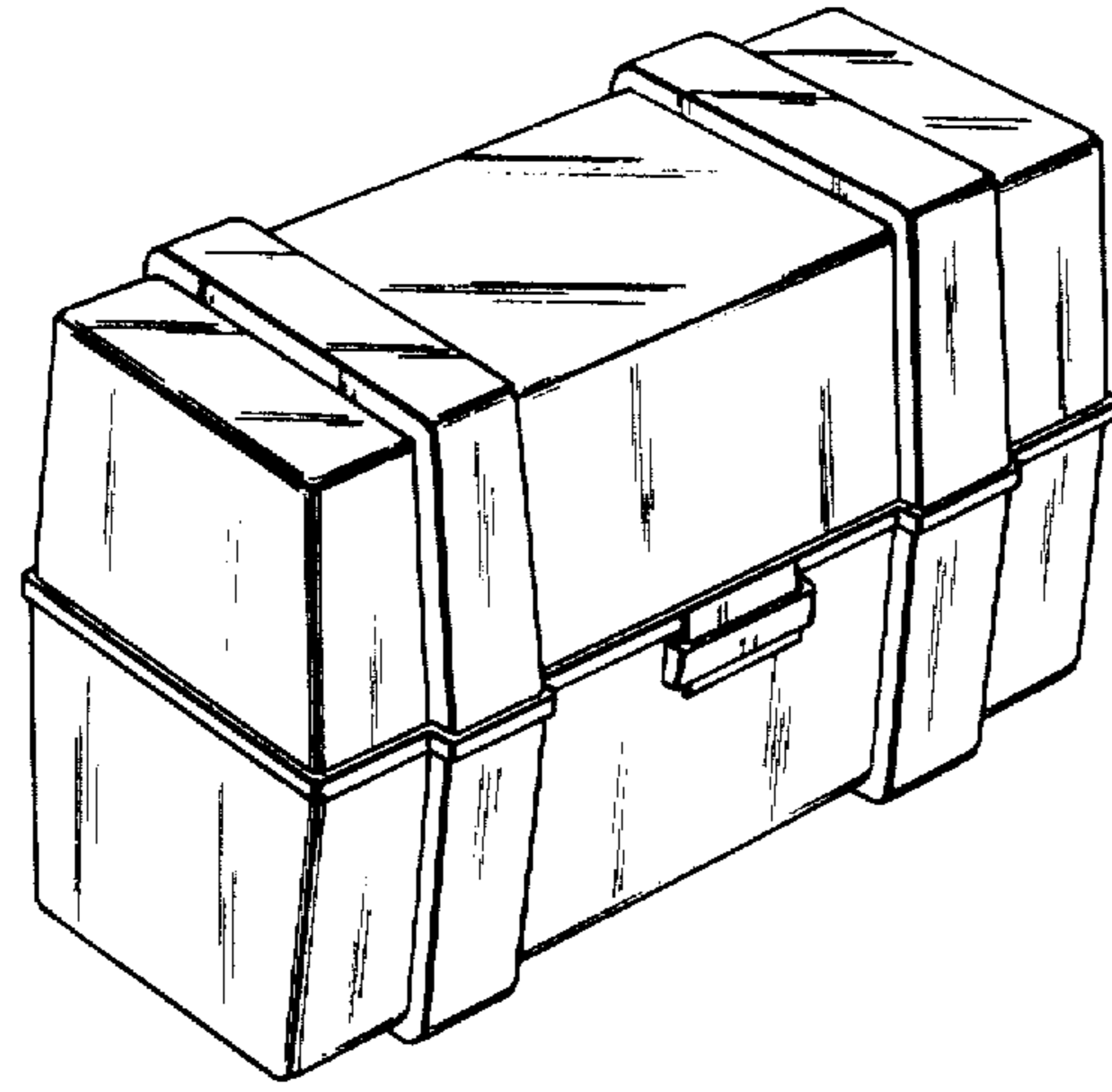

Fig. 1

Fig. 3

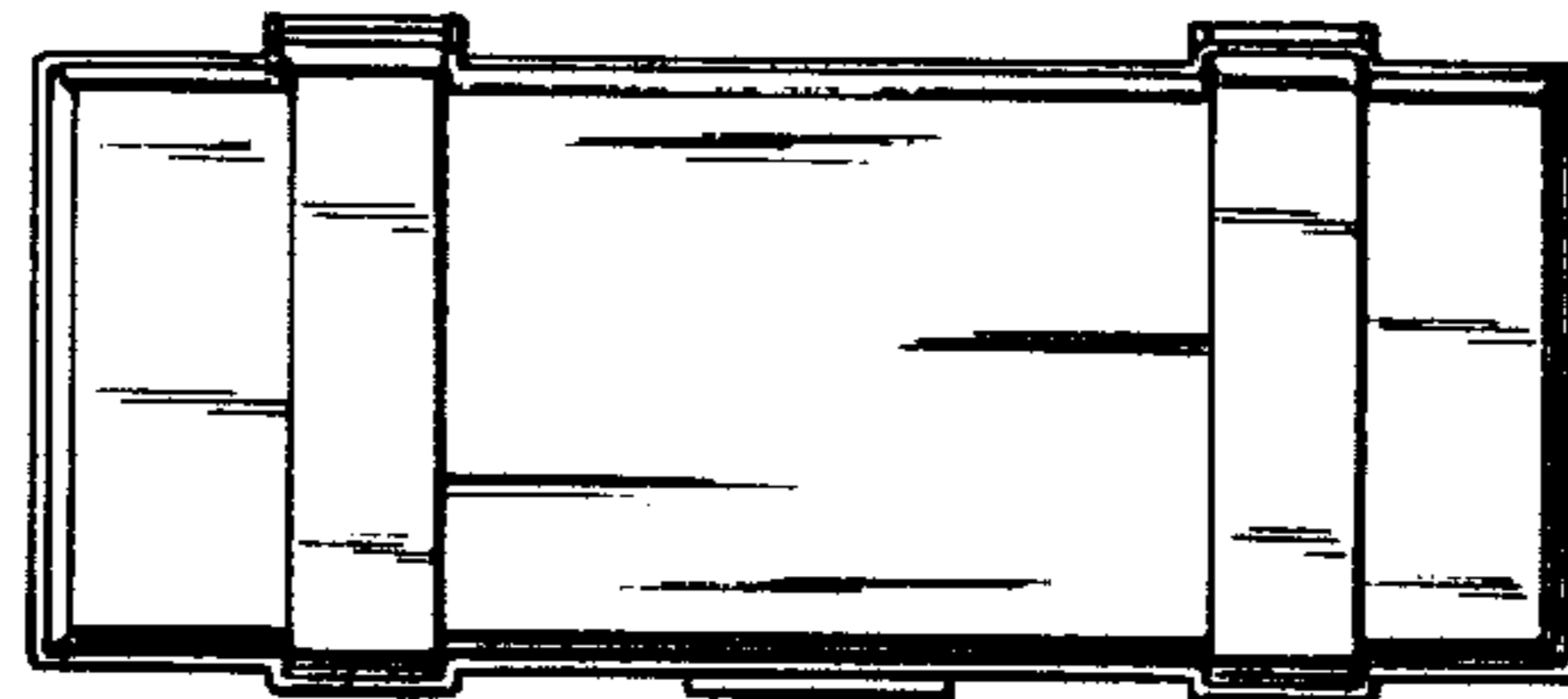

Fig. 2

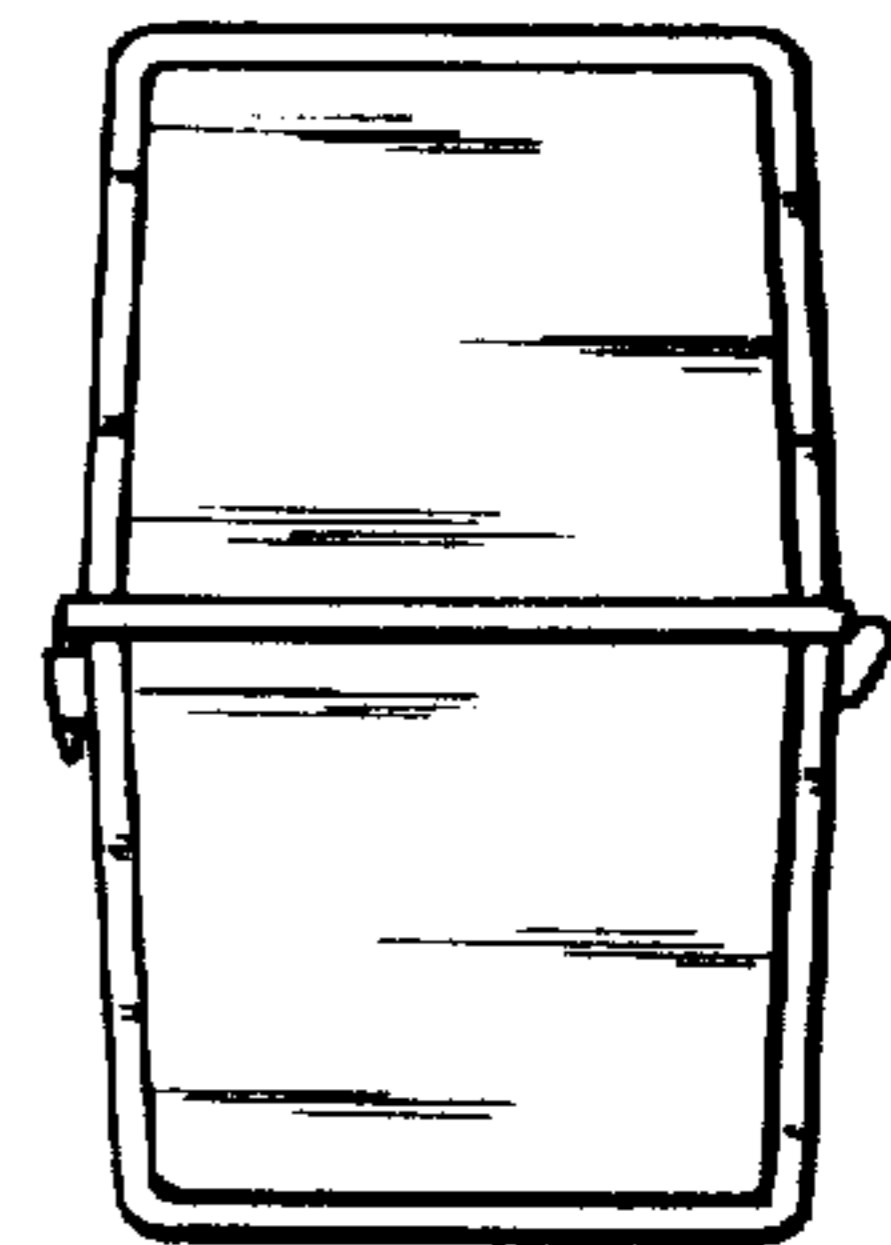
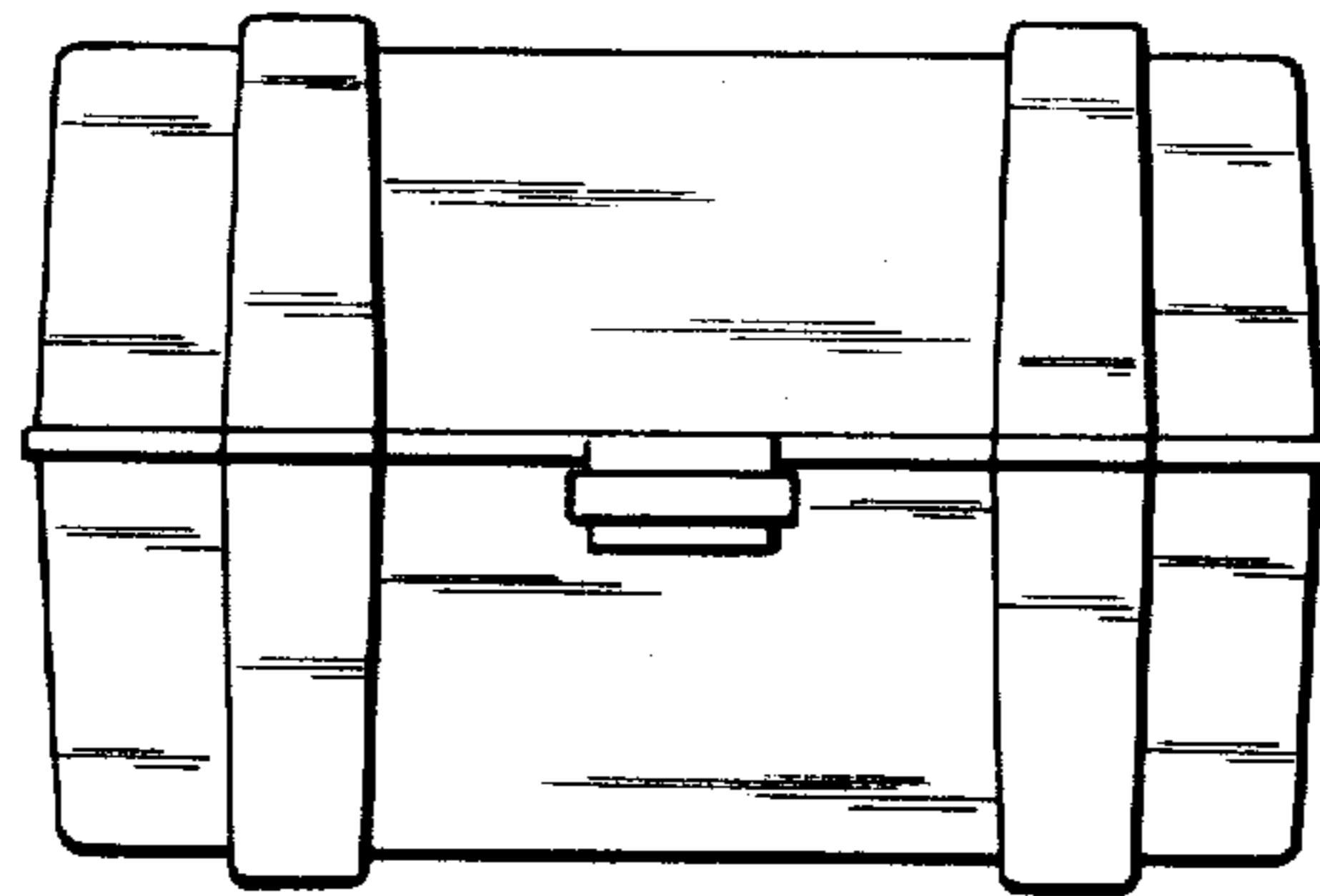

Fig. 4

Fig. 5

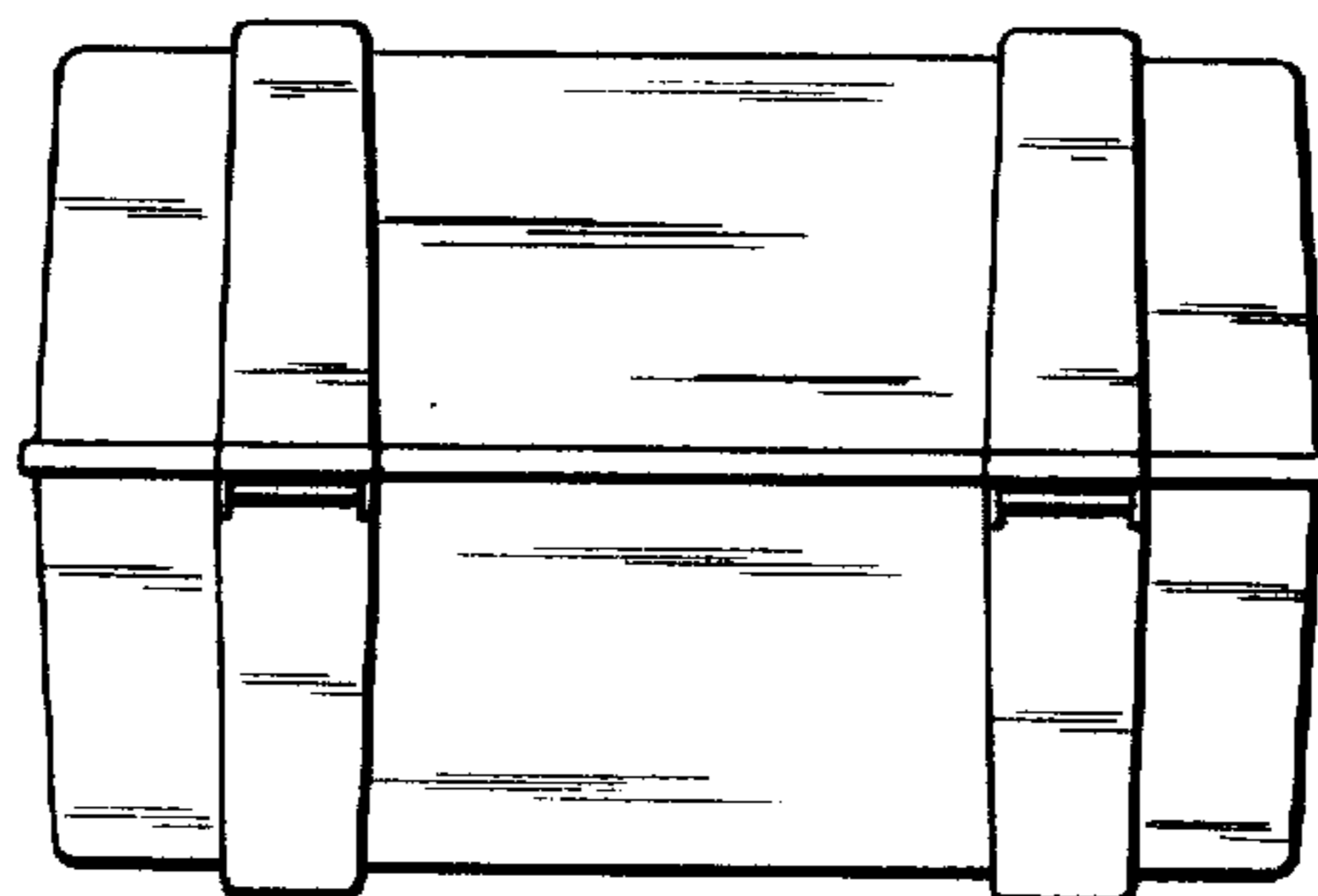

Fig. 6

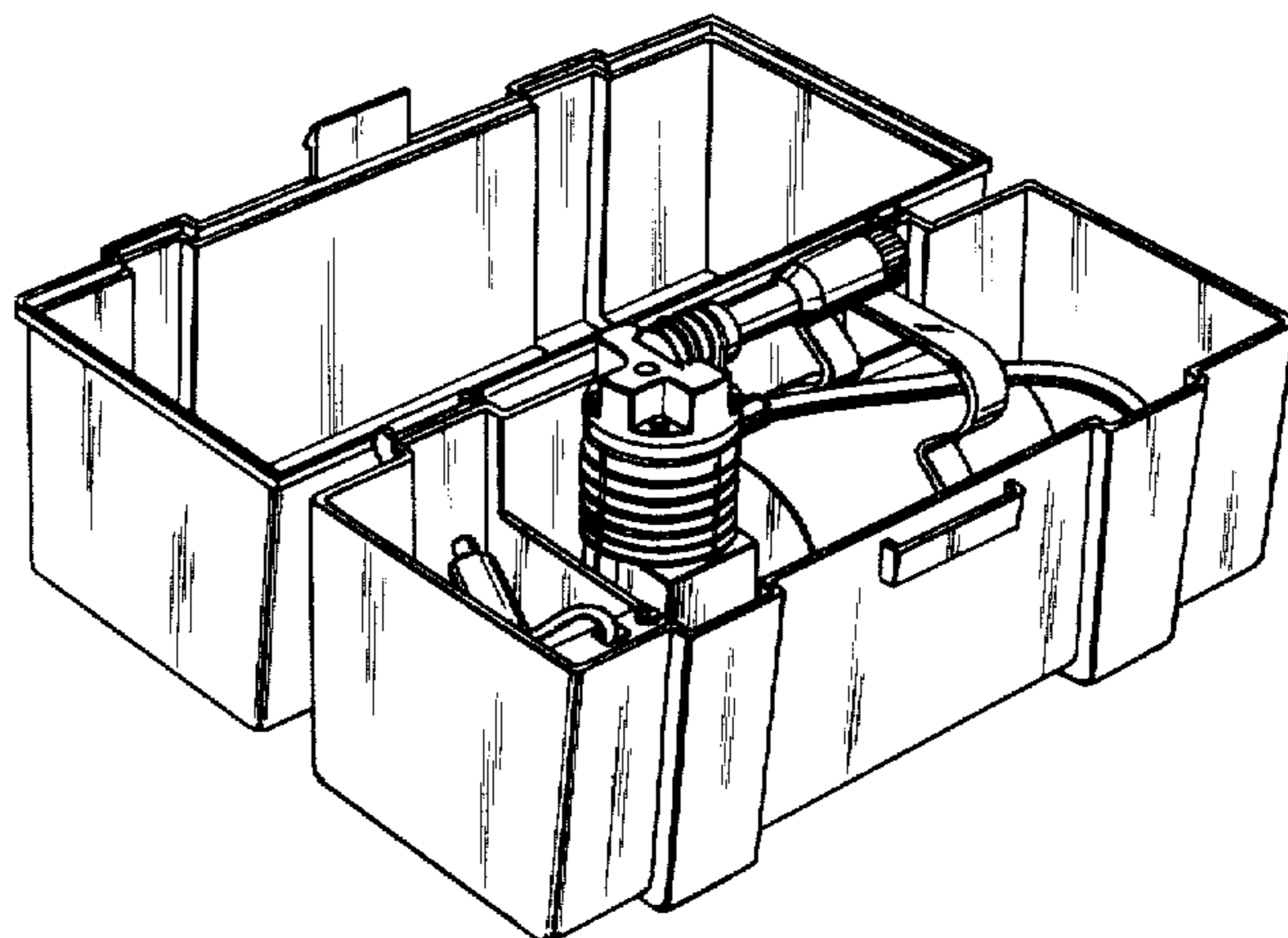

Fig. 8

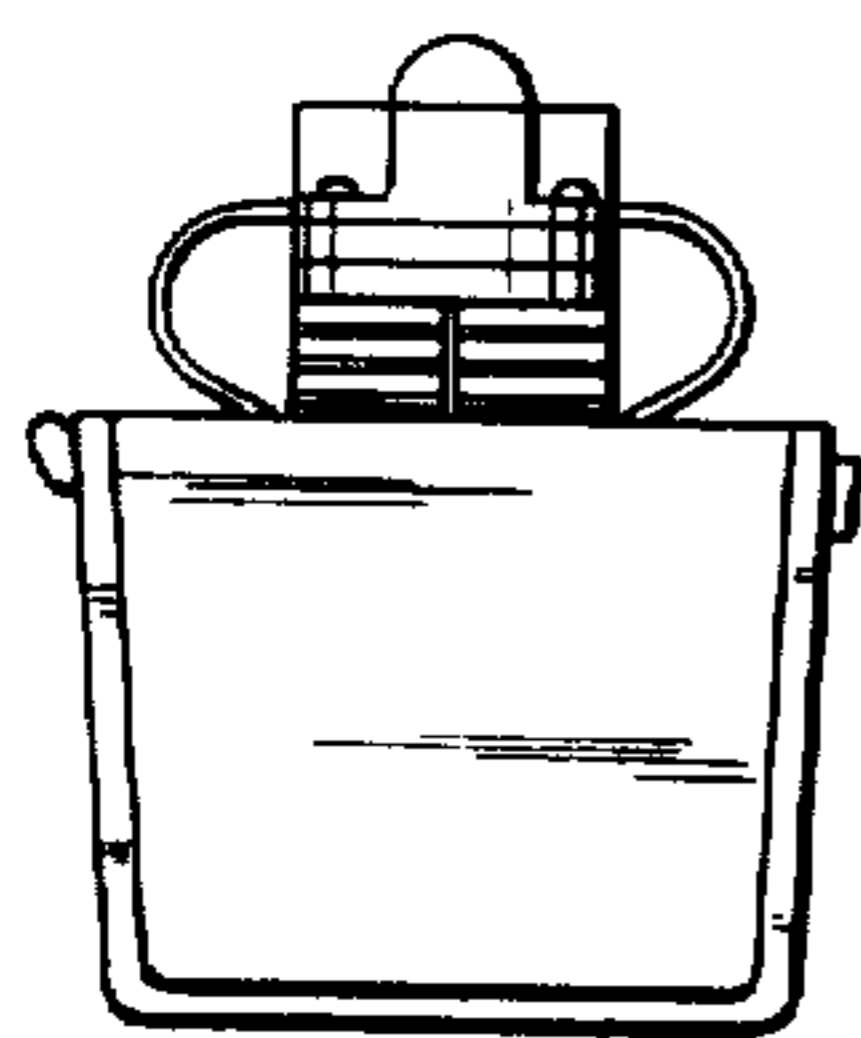
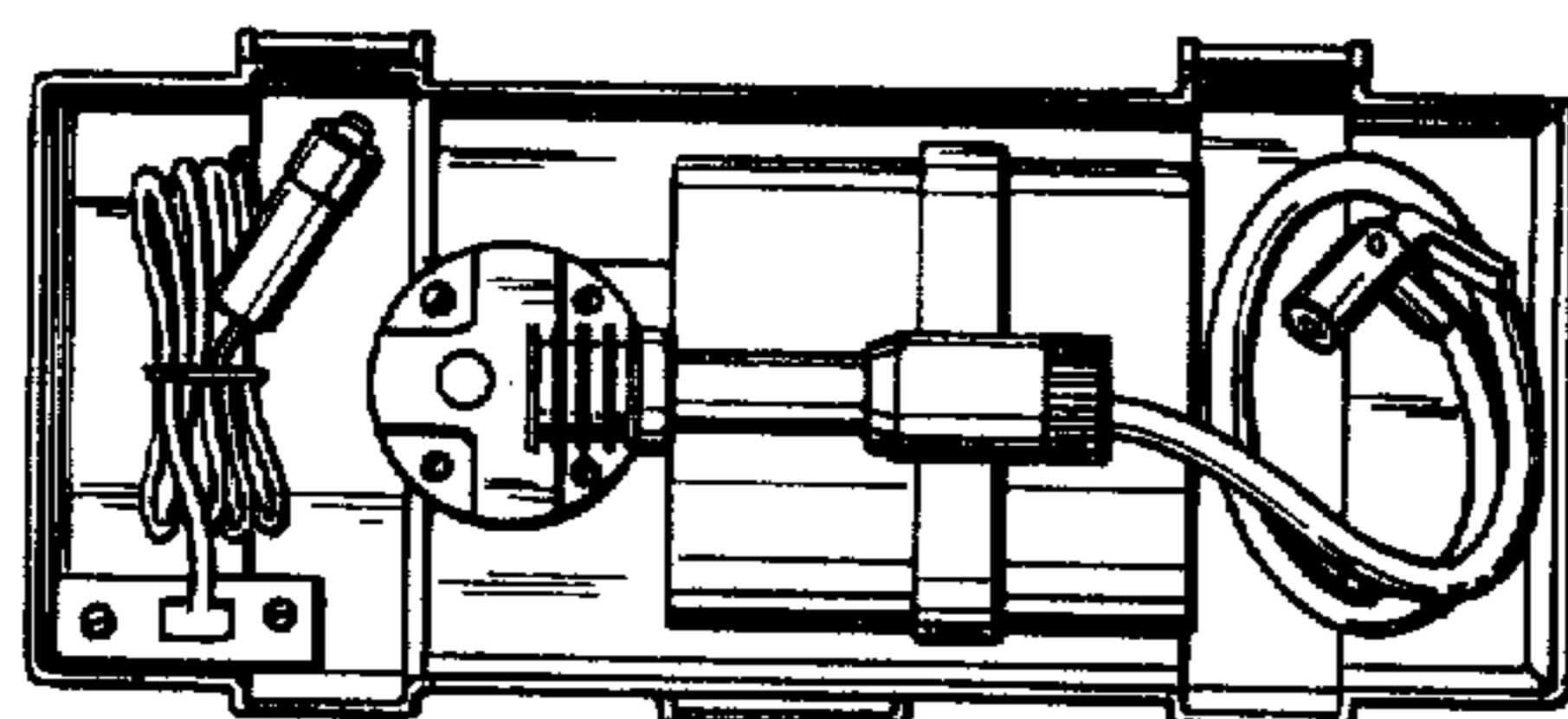

Fig. 10

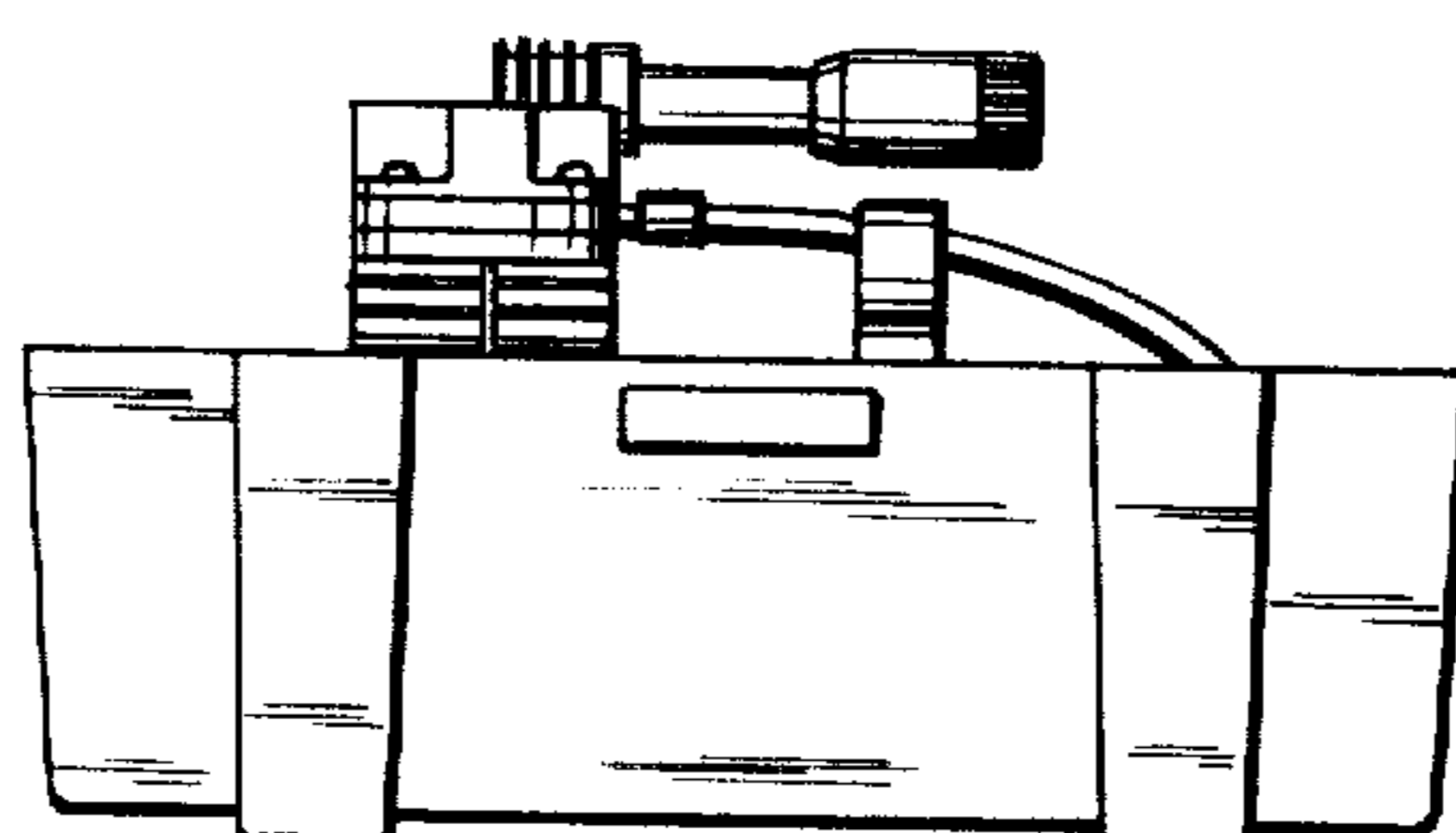

Fig. 7

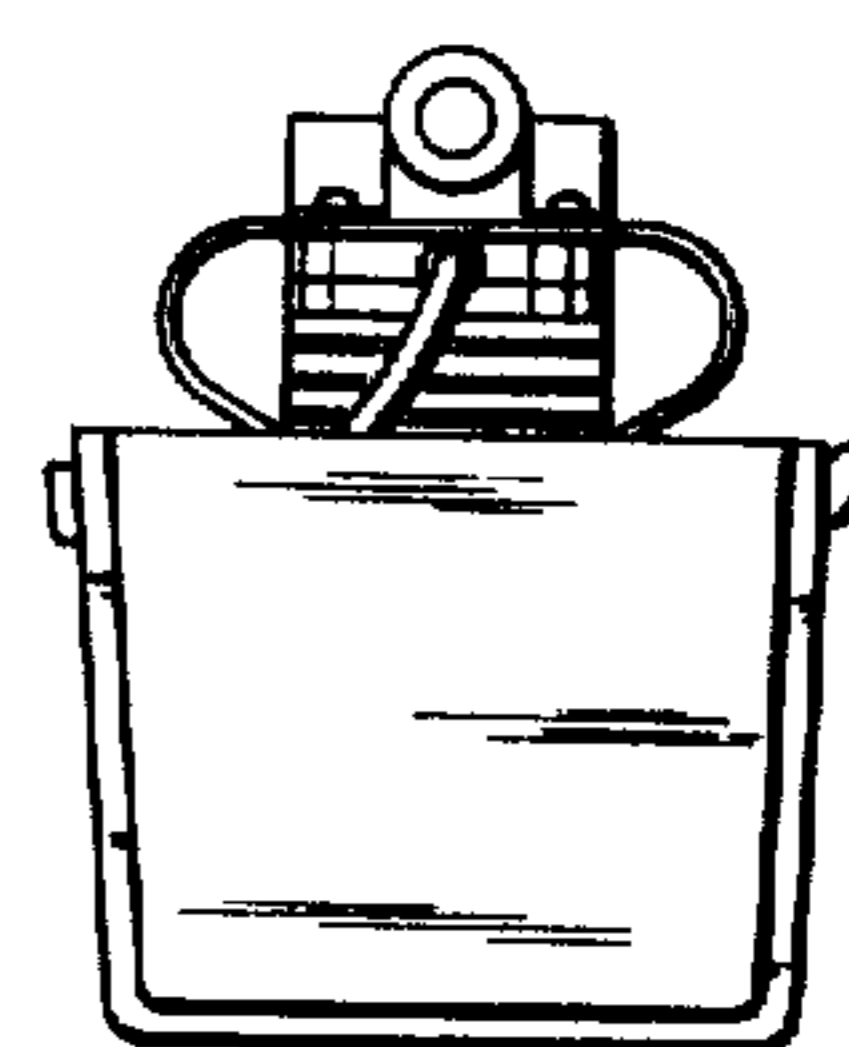

Fig. 9

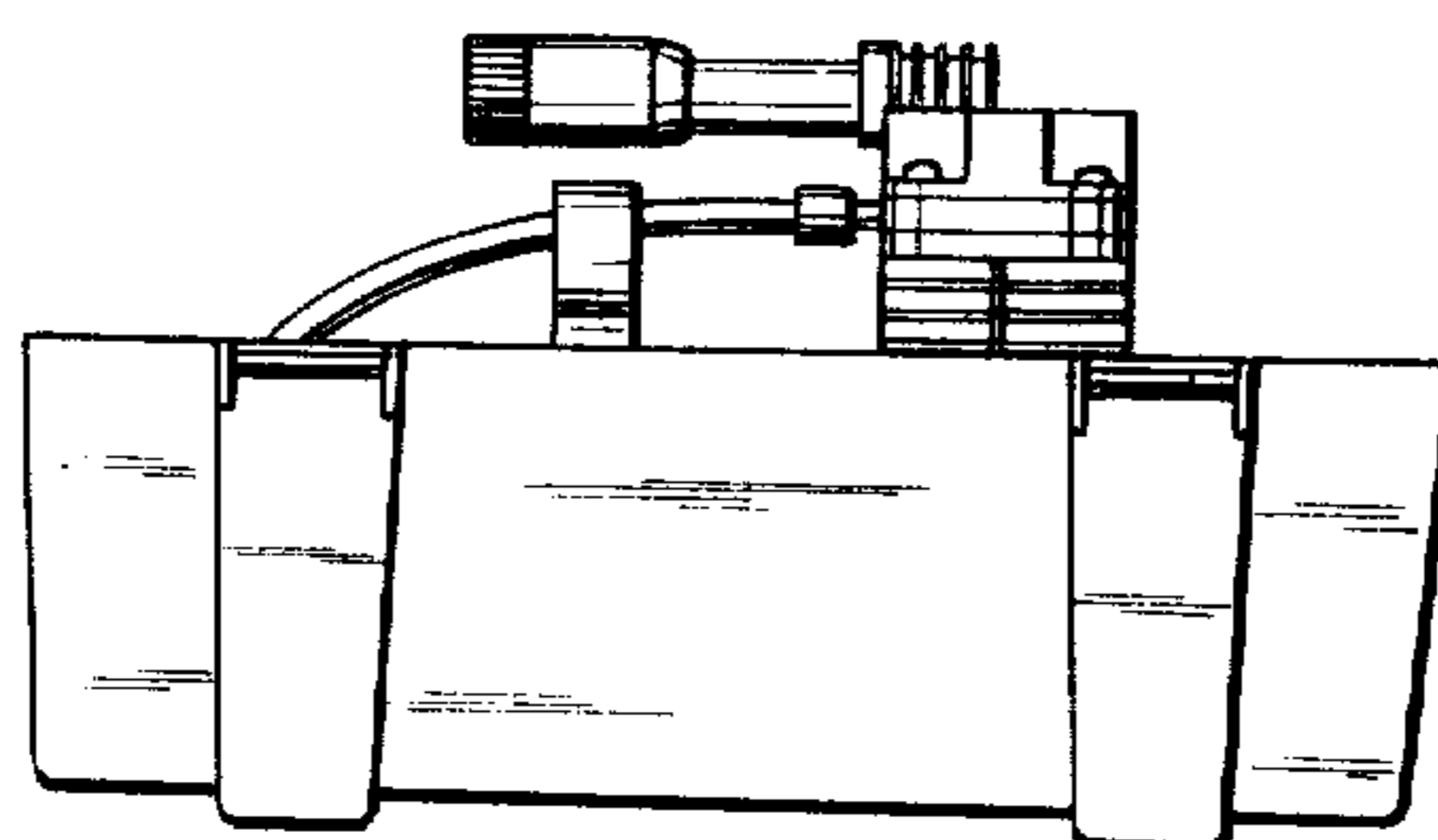

Fig. 11