

[54] COMBINED WHEEL CENTER AND HUB

[76] Inventor: Merlyn R. Reppert, 28045 Palos Verdes Dr. E., Rancho Palos Verdes, Calif. 90274

[**] Term: 14 Years

[21] Appl. No.: 176,598

[22] Filed: Aug. 8, 1980

D. 248,390 7/1978 Lester D12/205
D. 248,749 8/1978 Siroonian D12/211
1,935,765 11/1933 Burger 301/65

Primary Examiner—James M. Gandy
Attorney, Agent, or Firm—Thomas A. Seeman

[57] CLAIM

The ornamental design for a combined wheel center and hub, as shown and described.

DESCRIPTION

FIG. 1 is a front elevational view of a combined wheel center and hub showing my new design; FIG. 2 is an end elevational view thereof with the front of the combined wheel center and hub facing upwardly; FIG. 3 is a cross sectional view thereof taken along line 3—3 in FIG. 1; FIG. 4 is a rear elevational view thereof; and FIG. 5 is an end elevational view thereof opposite to that shown in FIG. 2 and with the front of the combined wheel center and hub facing downwardly. The broken lines in FIGS. 1 and 3 of the drawings are for illustrative purposes only.

Related U.S. Application Data

[62] Division of Ser. No. 85,401, Oct. 16, 1979.

[51] Int. Cl. D12—16

[52] U.S. Cl. D12/209; D12/211

[58] Field of Search D12/205, 207, 209, 211;
301/37 R, 37 P, 63 R, 64 R, 64 SD, 65, 66, 104,
108 R

References Cited

U.S. PATENT DOCUMENTS

D. 237,703 11/1975 Clement et al. D12/211

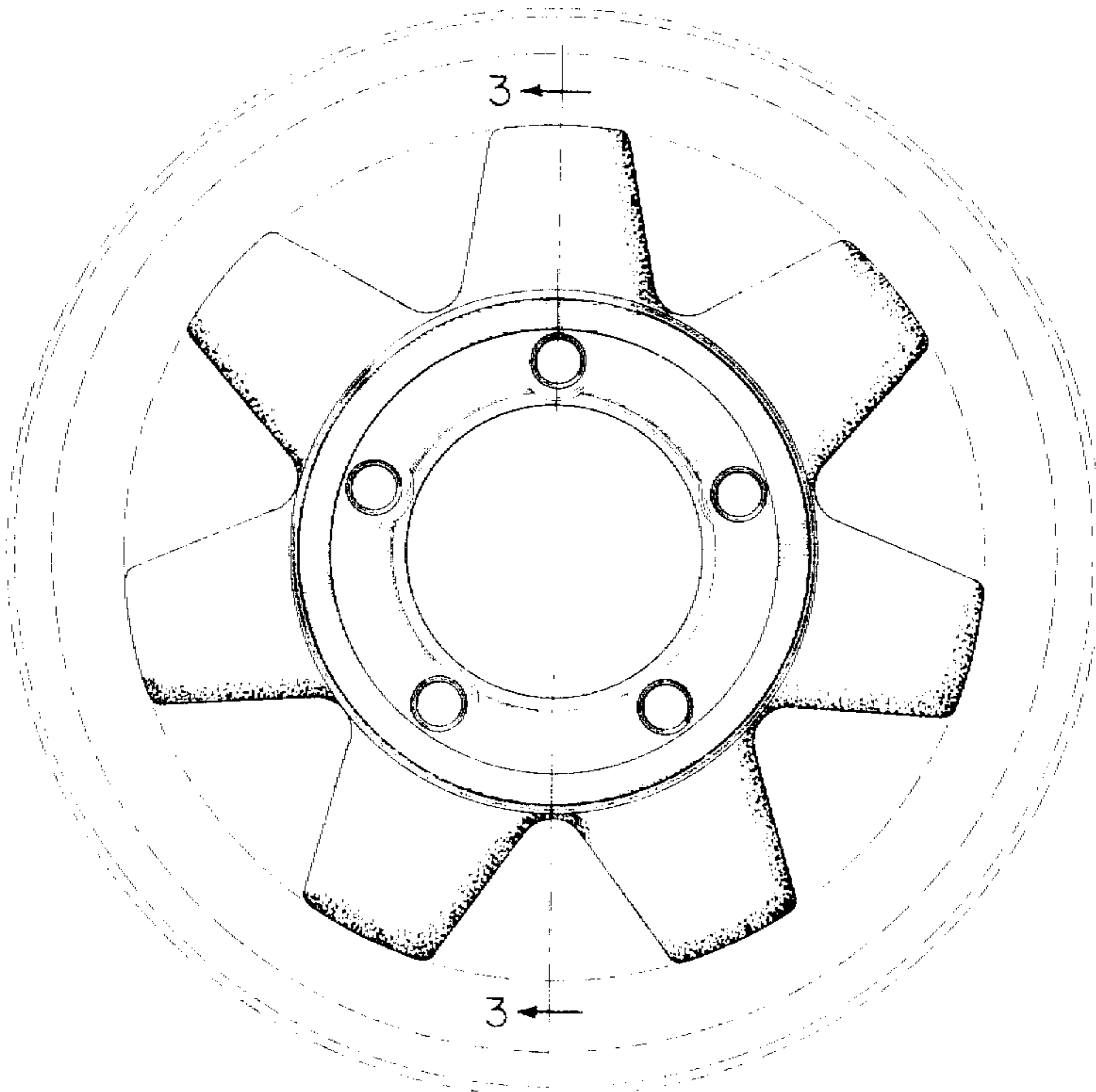
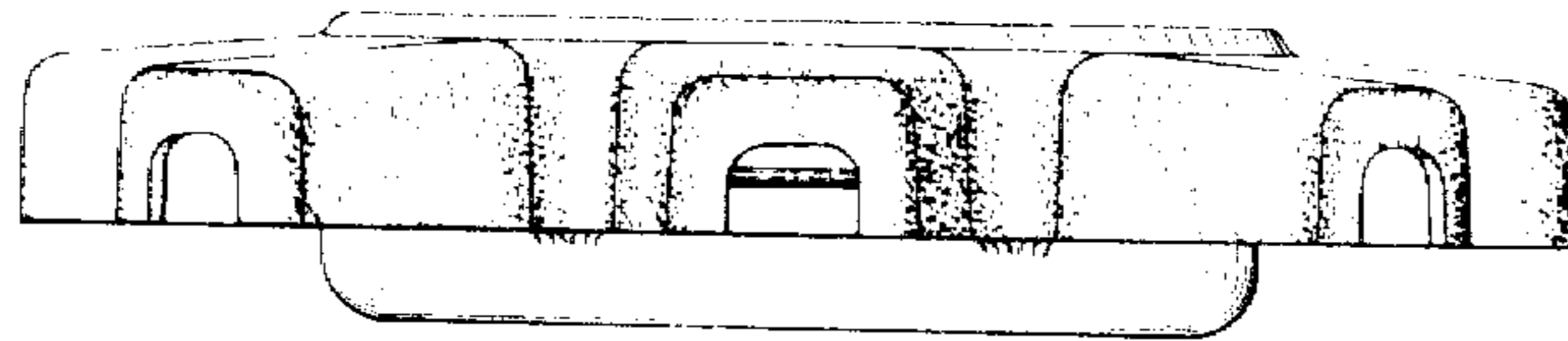

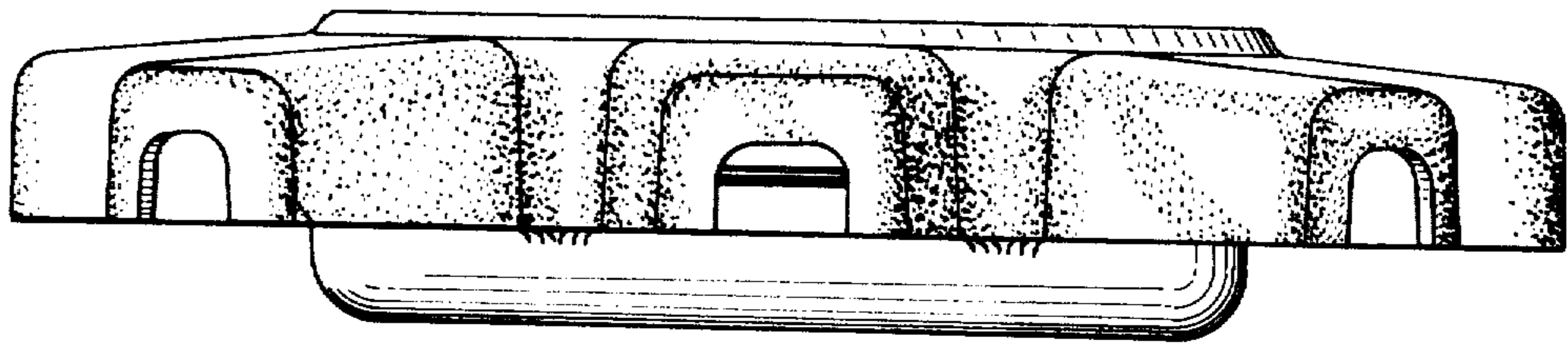

FIG. 2

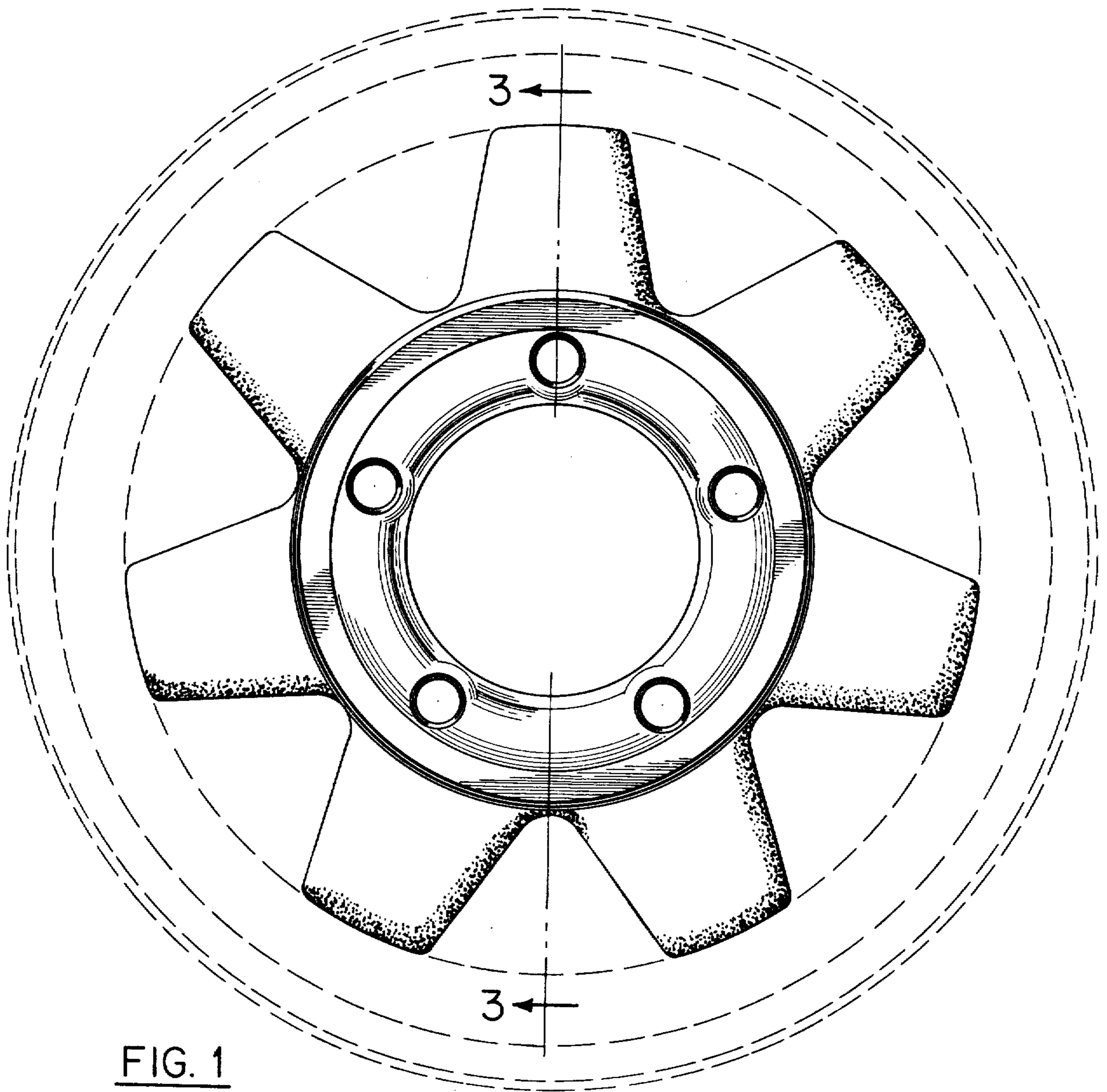

FIG. 1

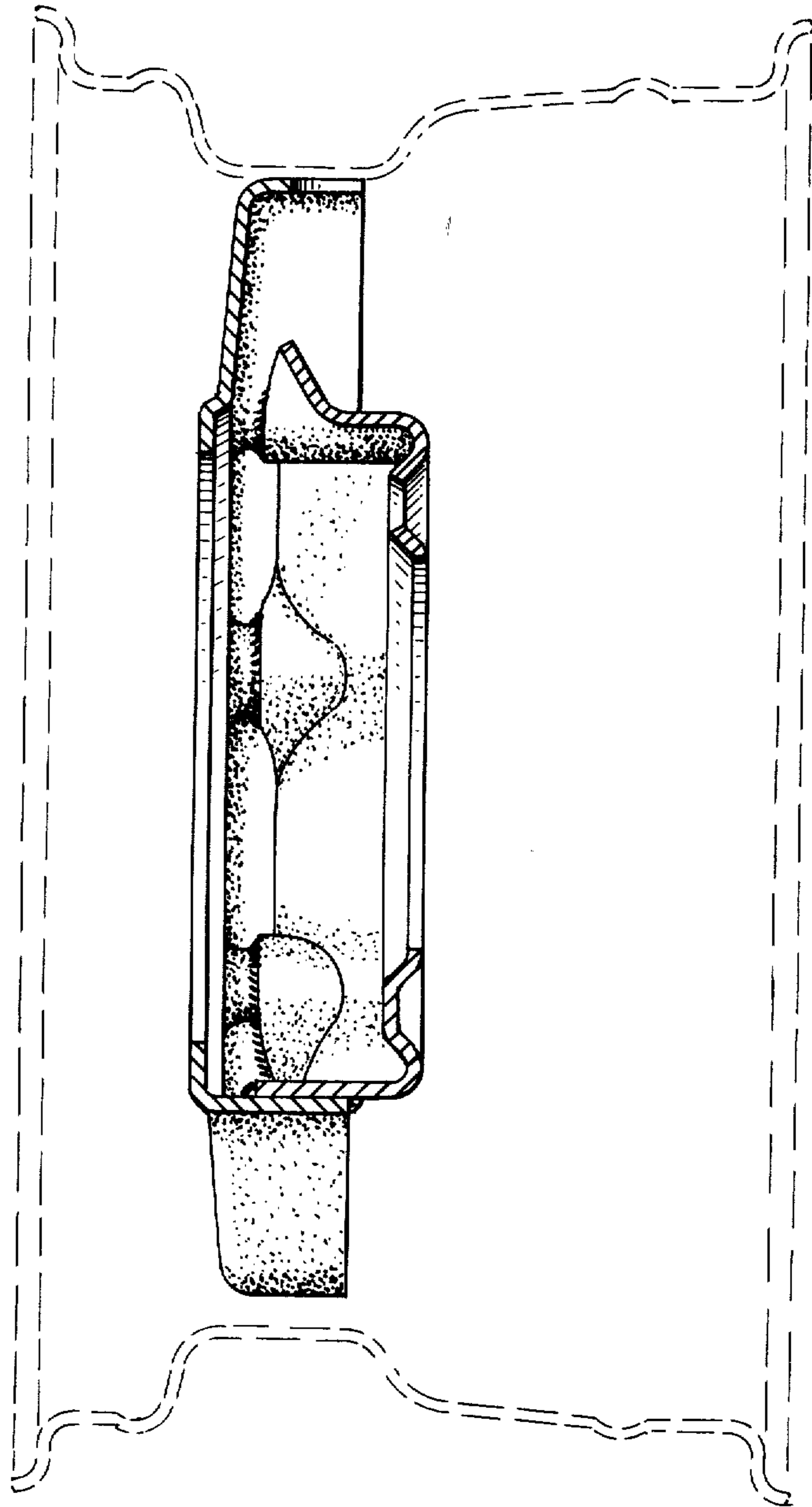

FIG. 3

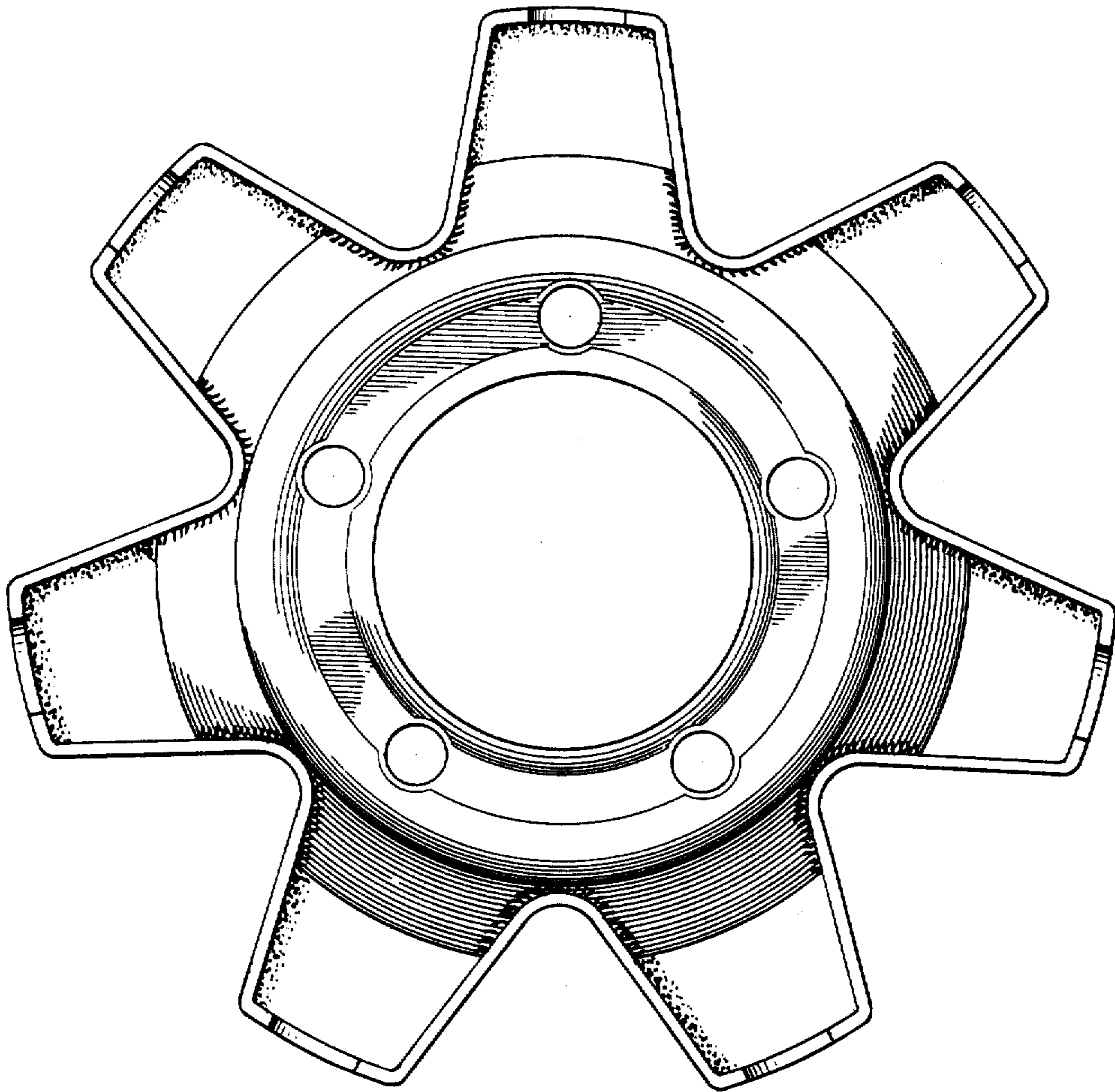

FIG. 4

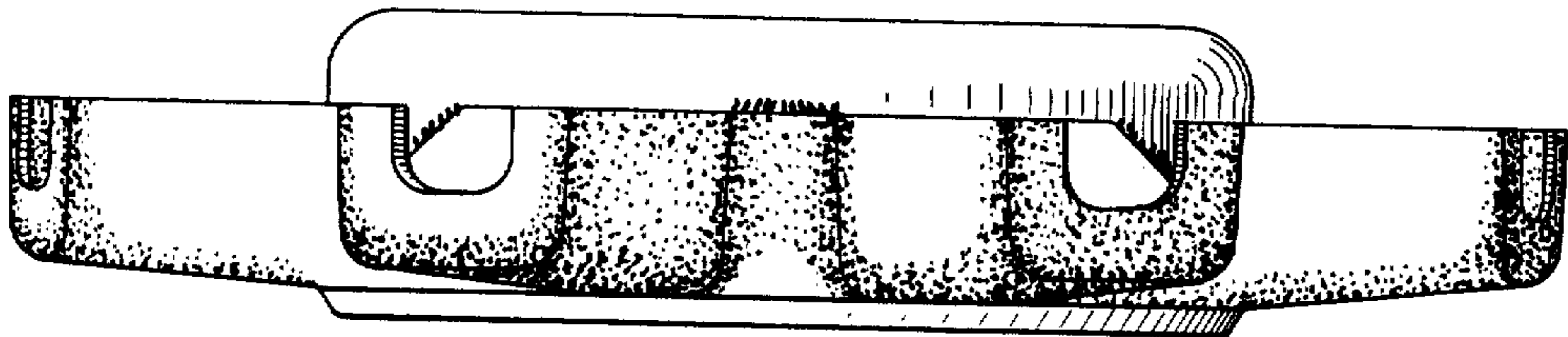

FIG. 5