

[54] FOOT CONTROL FOR AN ELECTRIC GOLF CAR OR THE LIKE

[76] Inventor: Craig A. Johnson, R.R. Rte. 1, Lake View, Iowa 51450

[\*\*] Term: 14 Years

[21] Appl. No.: 13,258

[22] Filed: Feb. 21, 1979

[51] Int. Cl. .... D12-16

[52] U.S. Cl. .... D12/174; D12/16

[58] Field of Search .... D12/16, 174; 74/512, 74/513, 478; 200/86.5, 153 C; 280/DIG. 5; 338/153

[56] References Cited

U.S. PATENT DOCUMENTS

D. 181,224	10/1957	Musgrave	.....	D12/16
D. 195,550	7/1963	McRae	.....	D12/16
1,441,669	1/1923	Egan	.....	338/153
2,383,725	8/1945	Landis et al.	.....	338/153
2,455,691	12/1948	McCulloch	.....	74/512

2,460,494	2/1949	Eisenberg et al.	.....	338/153
2,482,550	9/1949	Koertge et al.	.....	200/86.5
2,561,556	7/1951	Bell	.....	74/512
2,832,863	4/1958	Quimby	.....	200/86.5
3,598,947	8/1971	Osborn	.....	200/86.5

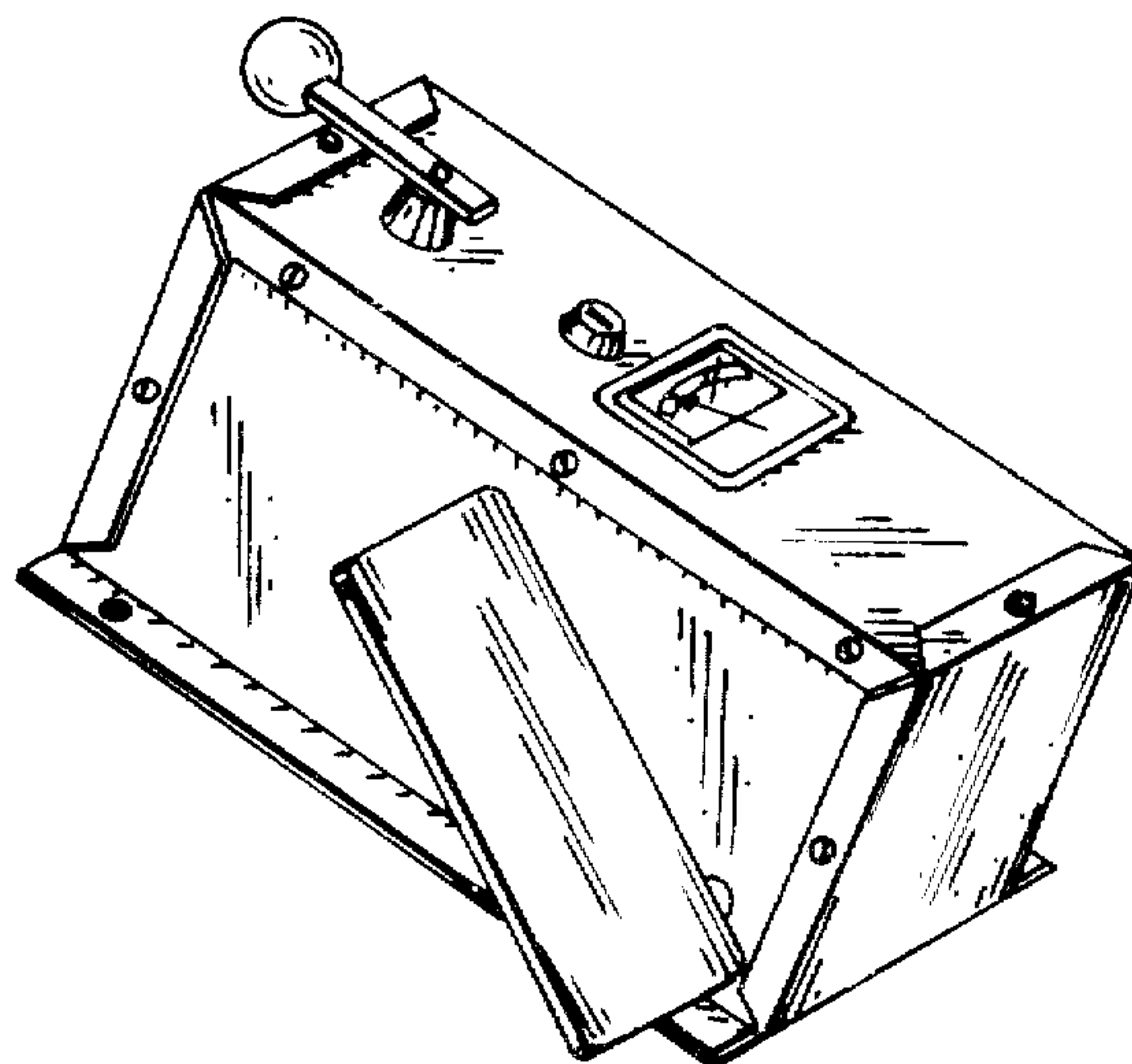
Primary Examiner—T. Tung  
Attorney, Agent, or Firm—Henderson & Sturm

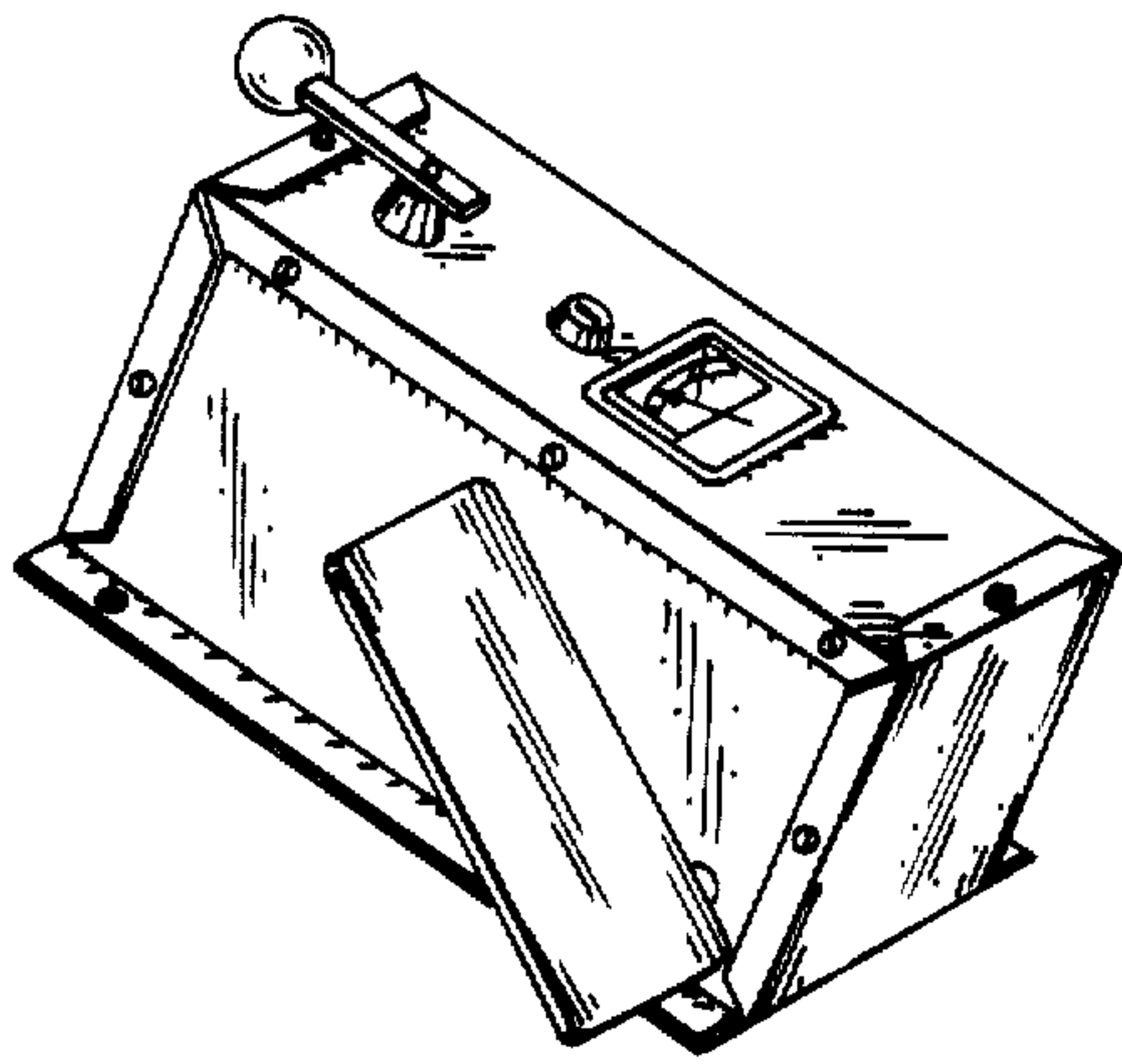
[57] CLAIM

The ornamental design for foot control for an electric golf car or the like, as shown.

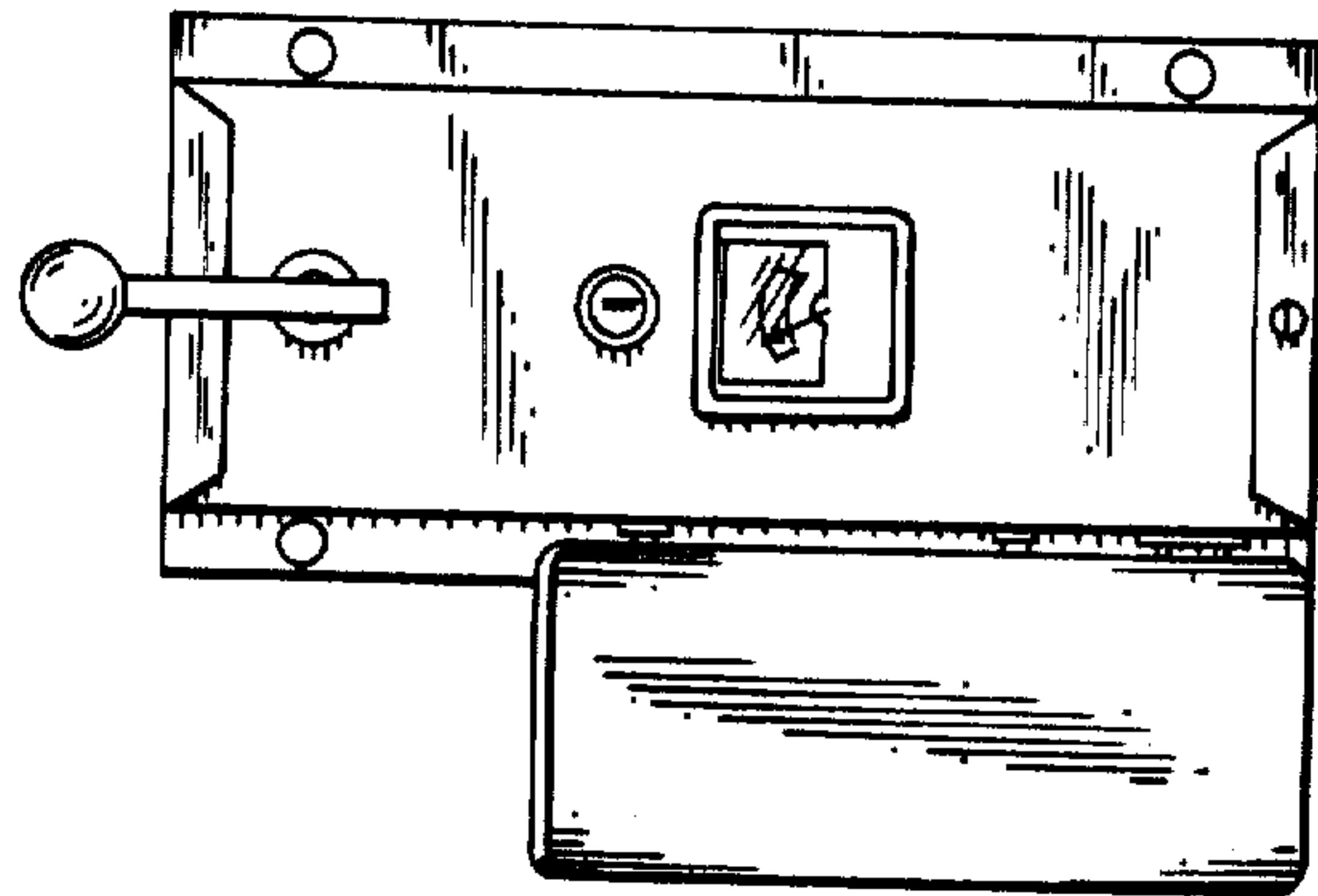
DESCRIPTION

FIG. 1 is a front perspective view of the foot control for an electric golf car or the like showing my new design; FIG. 2 is a top plan view thereof; FIG. 3 is a front elevational view thereof; FIG. 4 is a side elevational view thereof, taken from the side of the foot pedal; FIG. 5 is a rear elevational view thereof; FIG. 6 is a side elevational view thereof, taken from the side opposite the foot pedal; and FIG. 7 is a bottom plan view thereof.

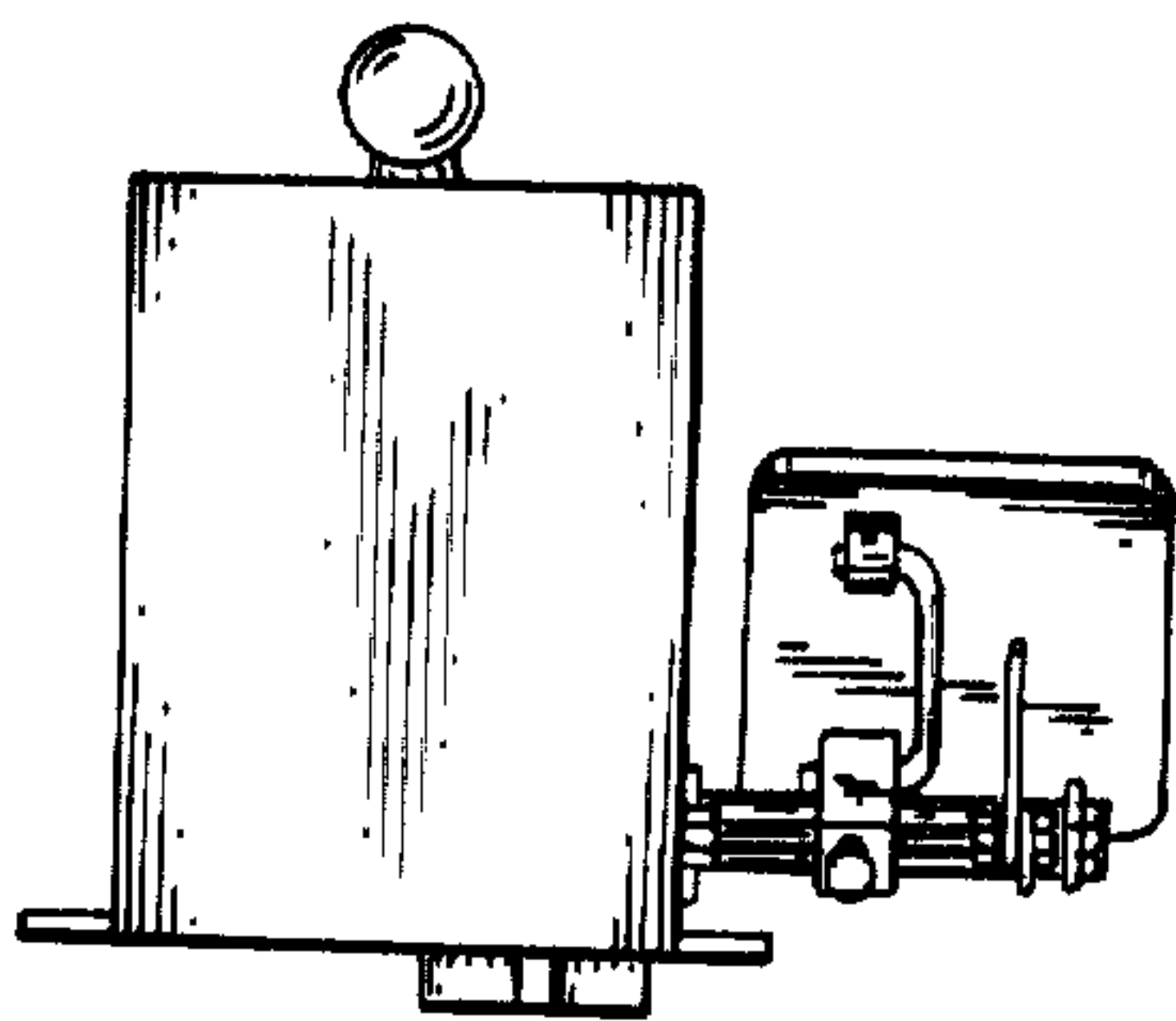




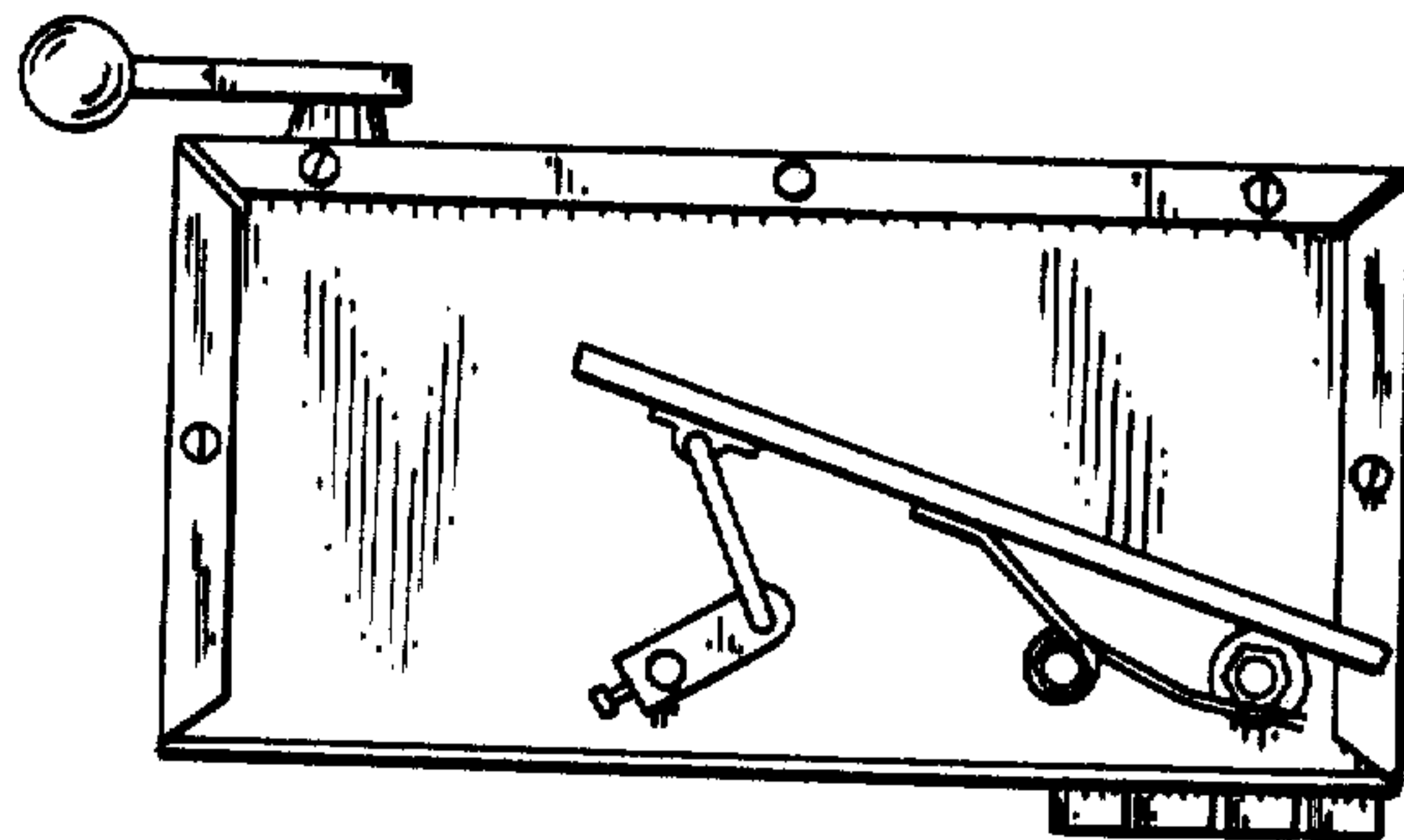
*Fig. 1*



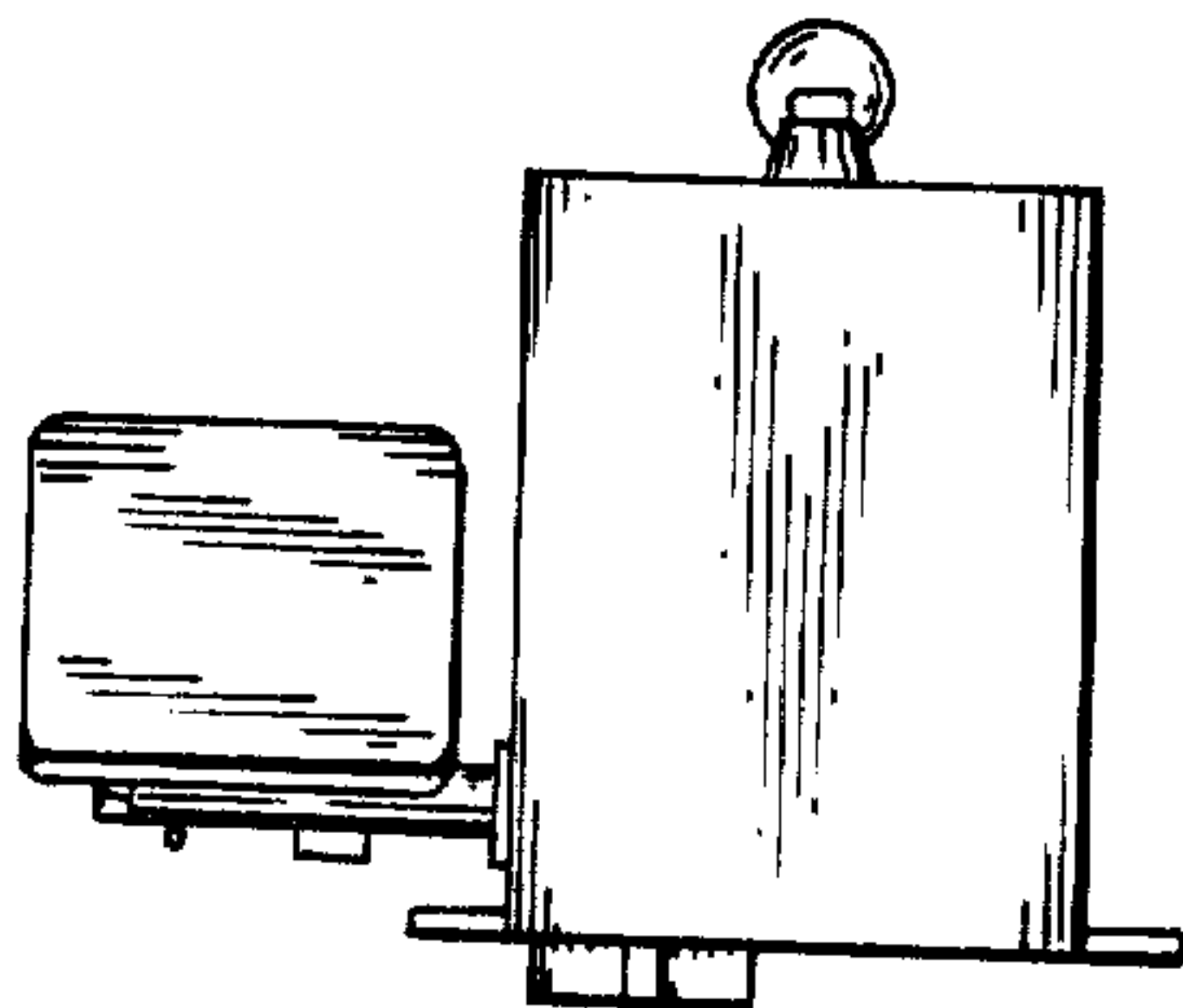
*Fig. 2*



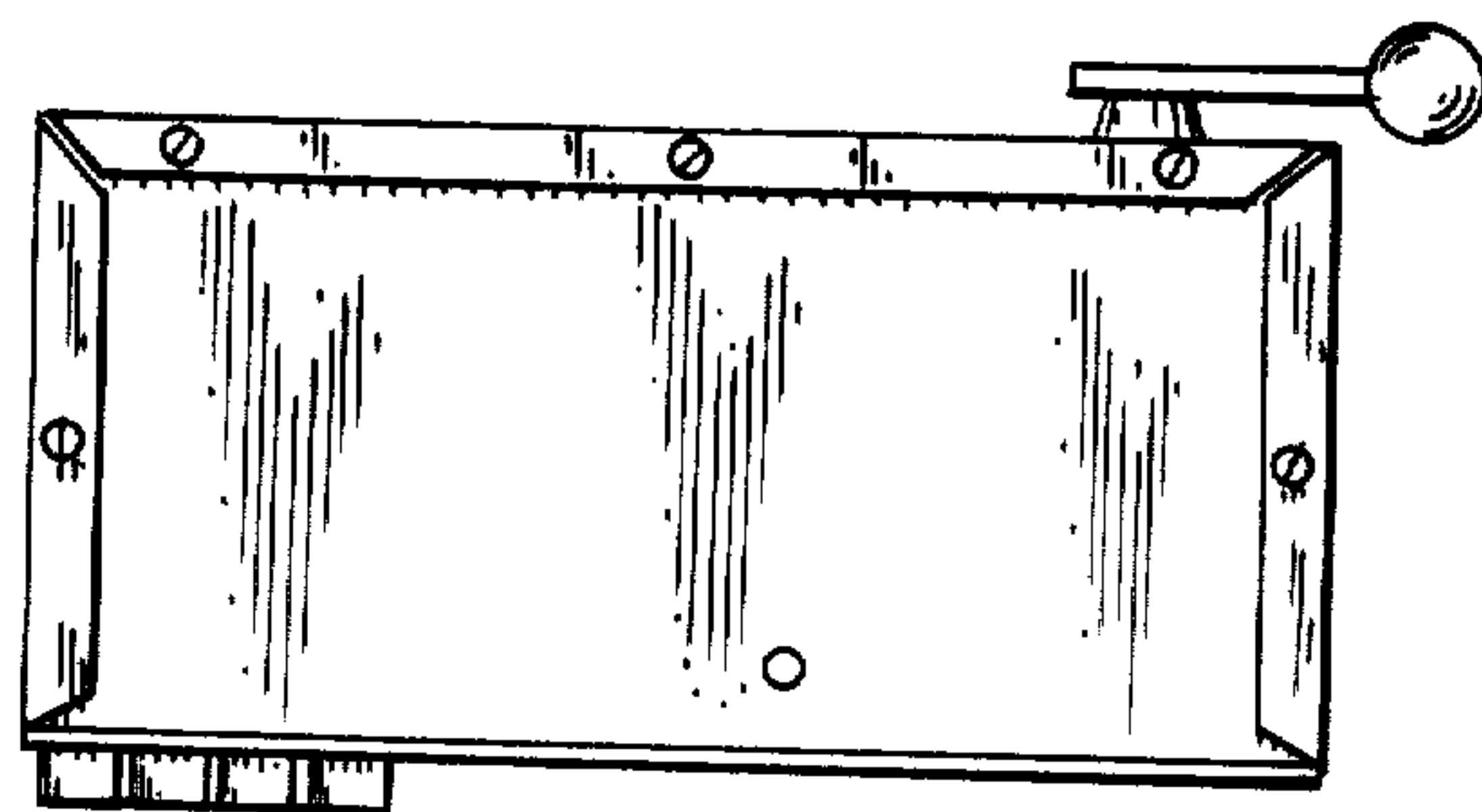
*Fig. 3*



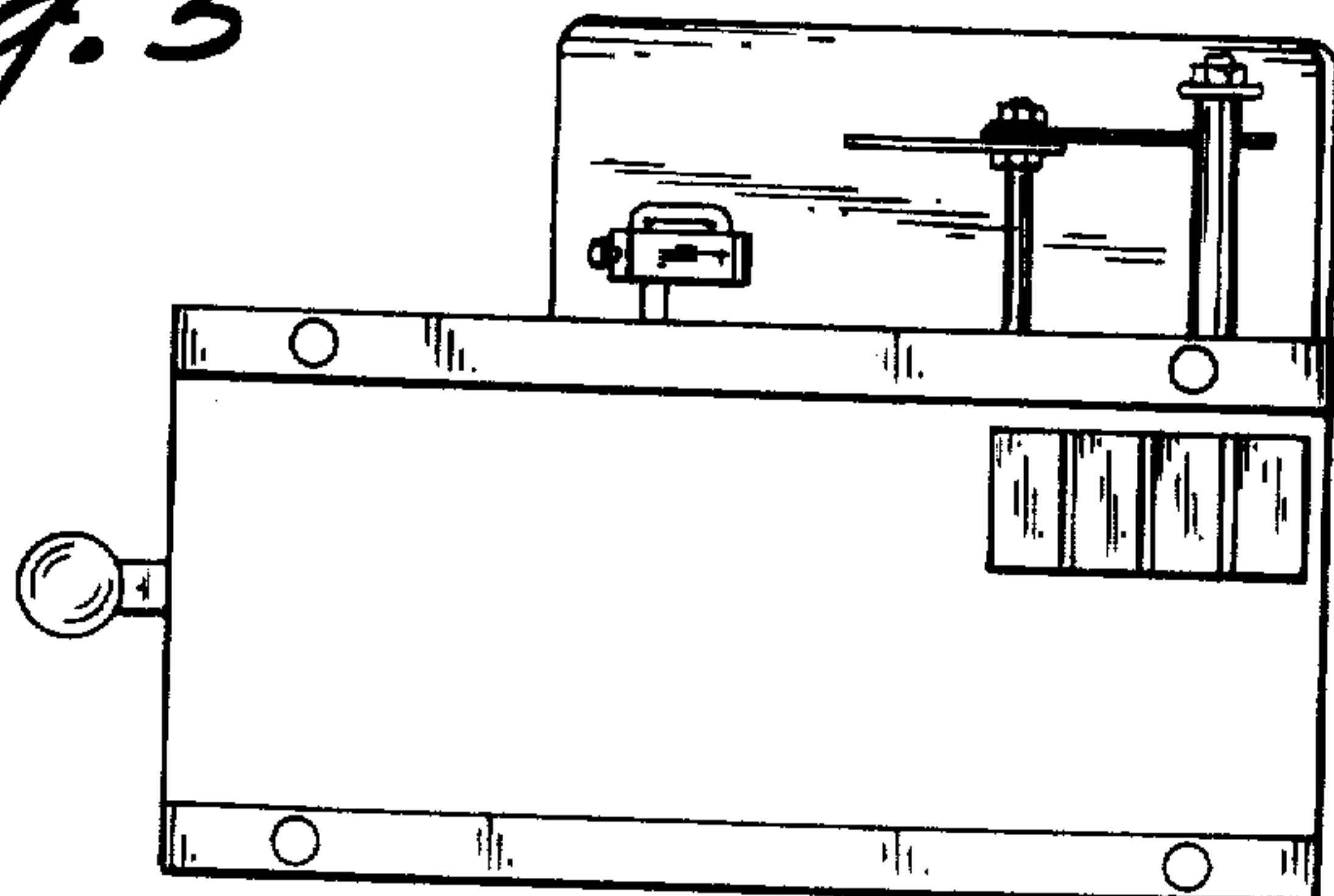
*Fig. 4*



*Fig. 5*



*Fig. 6*



*Fig. 7*