

[54] AUTOMOBILE

[76] Inventor: W. Allen Cargile, 4210 Estes Rd., Nashville, Tenn. 37215

[\*\*] Term: 14 Years

[21] Appl. No.: 966,107

[22] Filed: Dec. 4, 1978

[51] Int. Cl. .... D12-08

[52] U.S. Cl. .... D12/85

[58] Field of Search ..... D12/85, 90, 91, 92; 180/210-212, 215; 296/185

[56] References Cited

U.S. PATENT DOCUMENTS

D. 248,461 7/1978 Edmonson ..... D12/85

OTHER PUBLICATIONS

Popular Mechanics, 4/74, p. 80, Duo Delta, bottom of page.

Primary Examiner—James M. Gandy  
Attorney, Agent, or Firm—Harrington A. Lackey

[57] CLAIM

The ornamental design for an automobile, as shown and described.

DESCRIPTION

FIG. 1 is a left side elevational view of an automobile showing my new design;

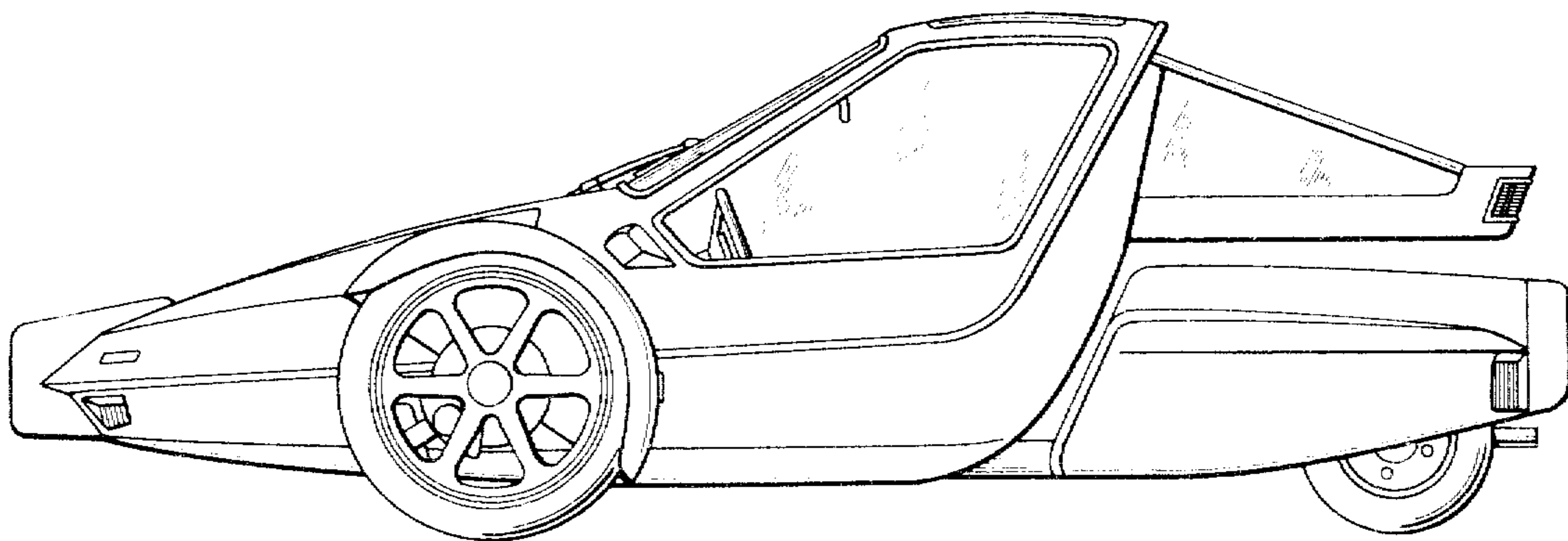
FIG. 2 is a top plan view thereof;

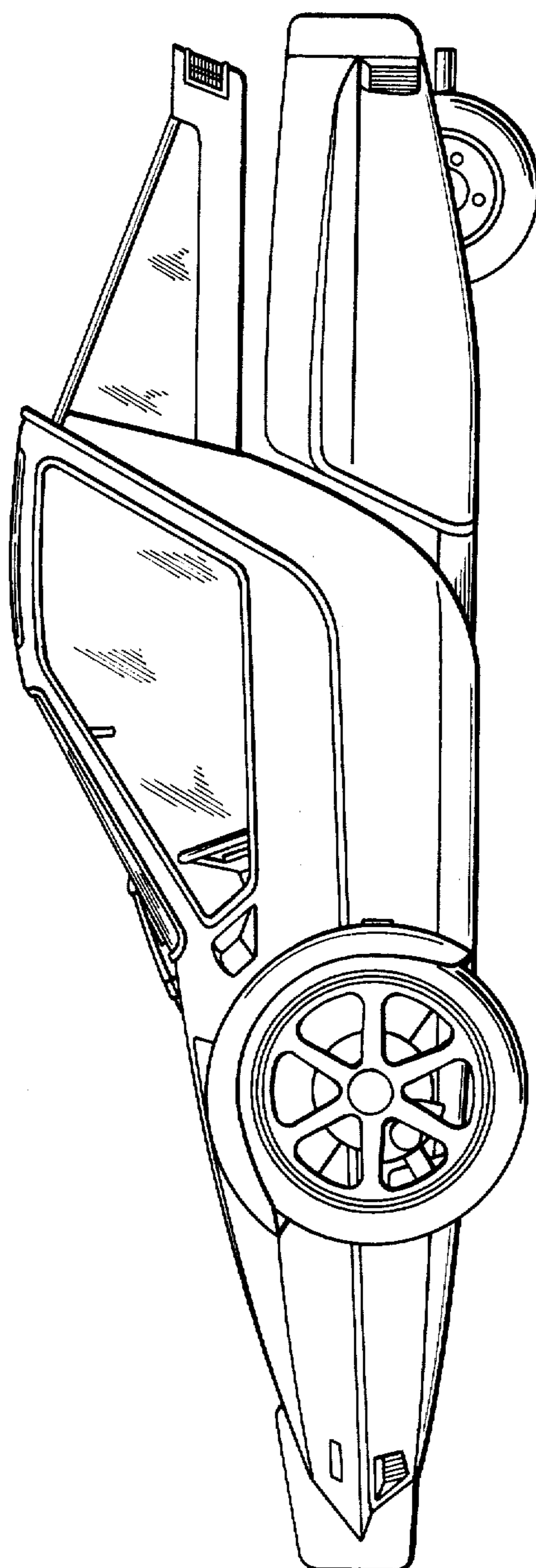
FIG. 3 is a front elevational view thereof;

FIG. 4 is a rear elevational view thereof;

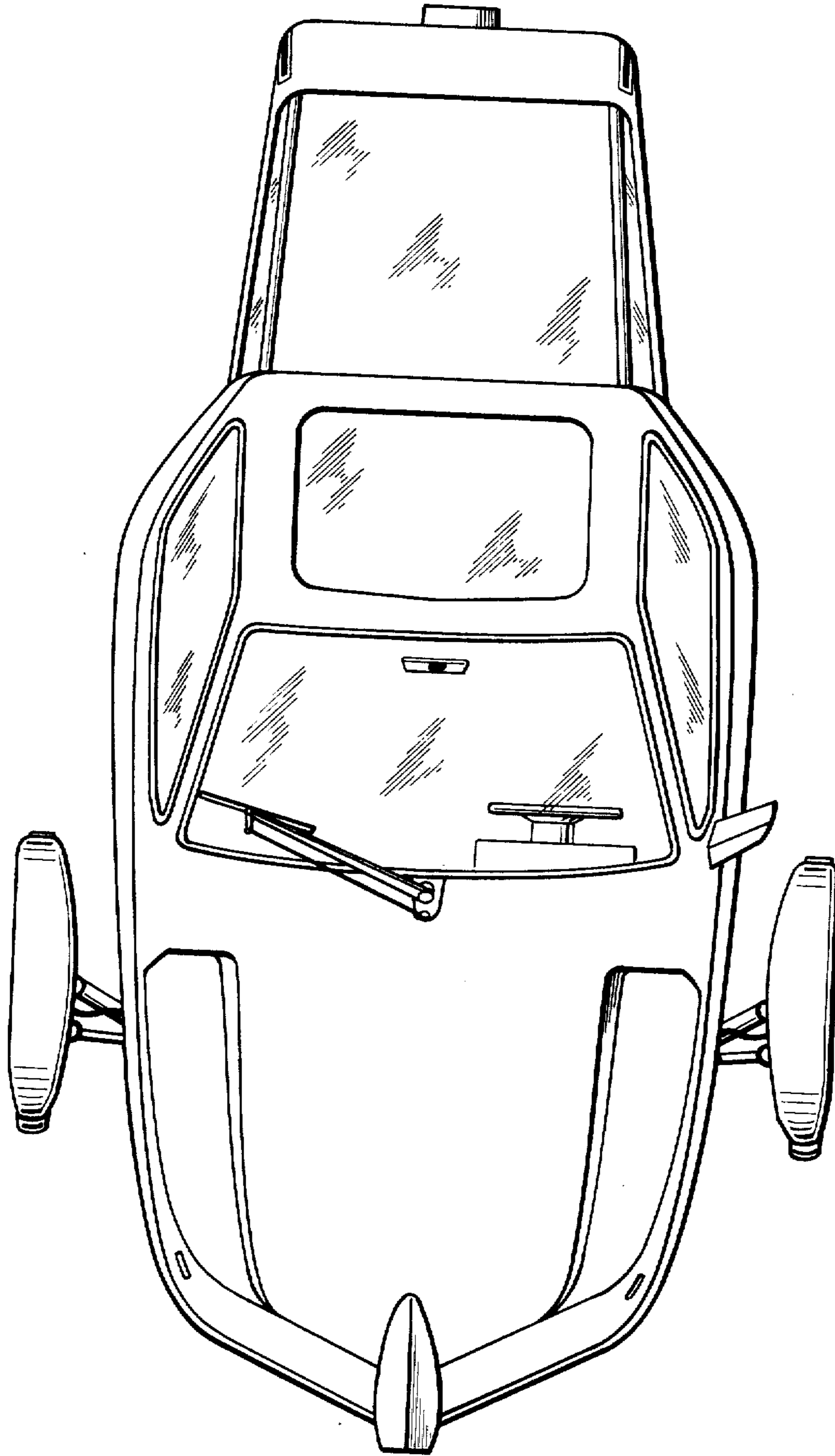
FIG. 5 is a front elevational view of an automobile showing a second embodiment of my new design, the sole difference being the use of two rear wheels instead of one; and

FIG. 6 is a rear elevational view of FIG. 5.

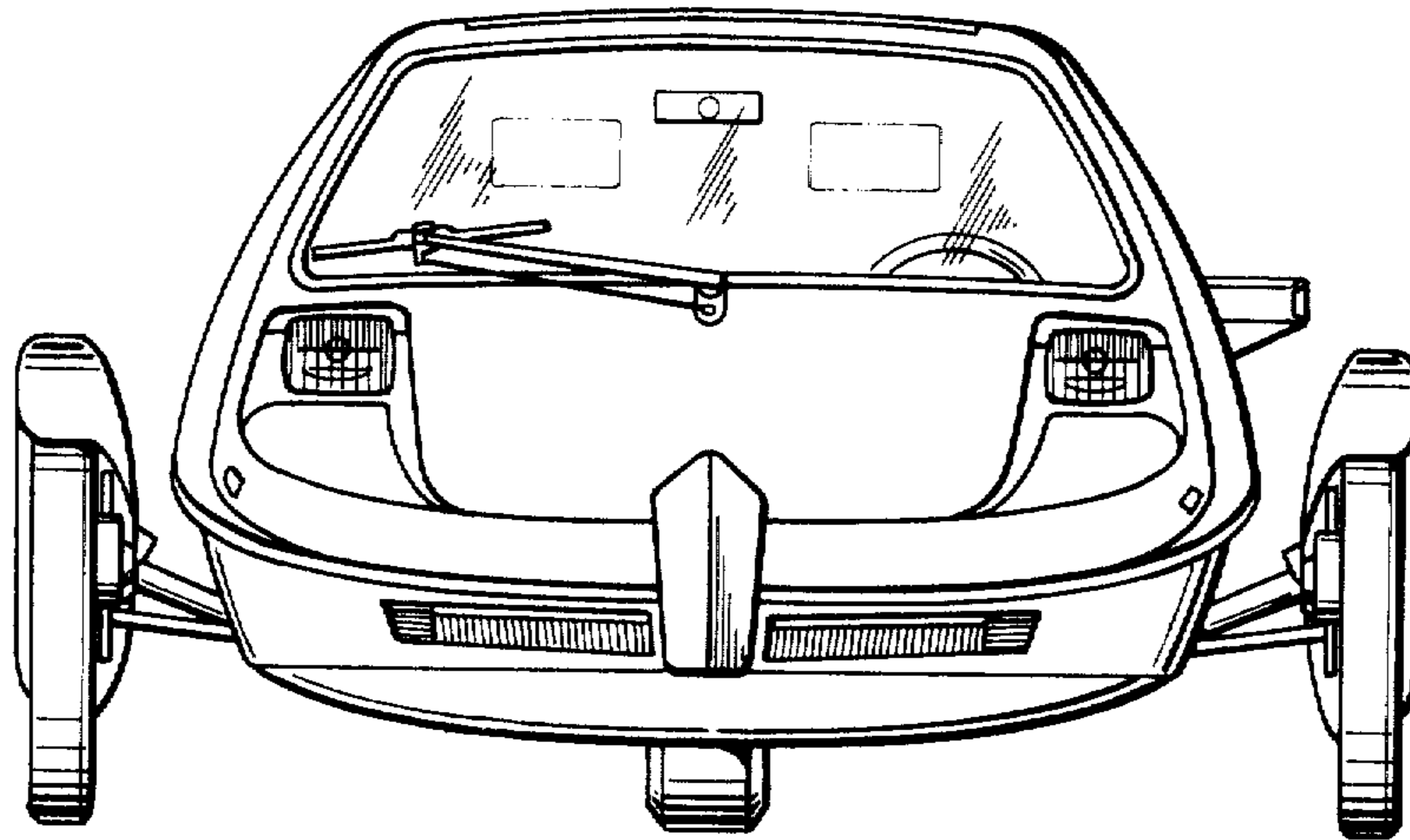




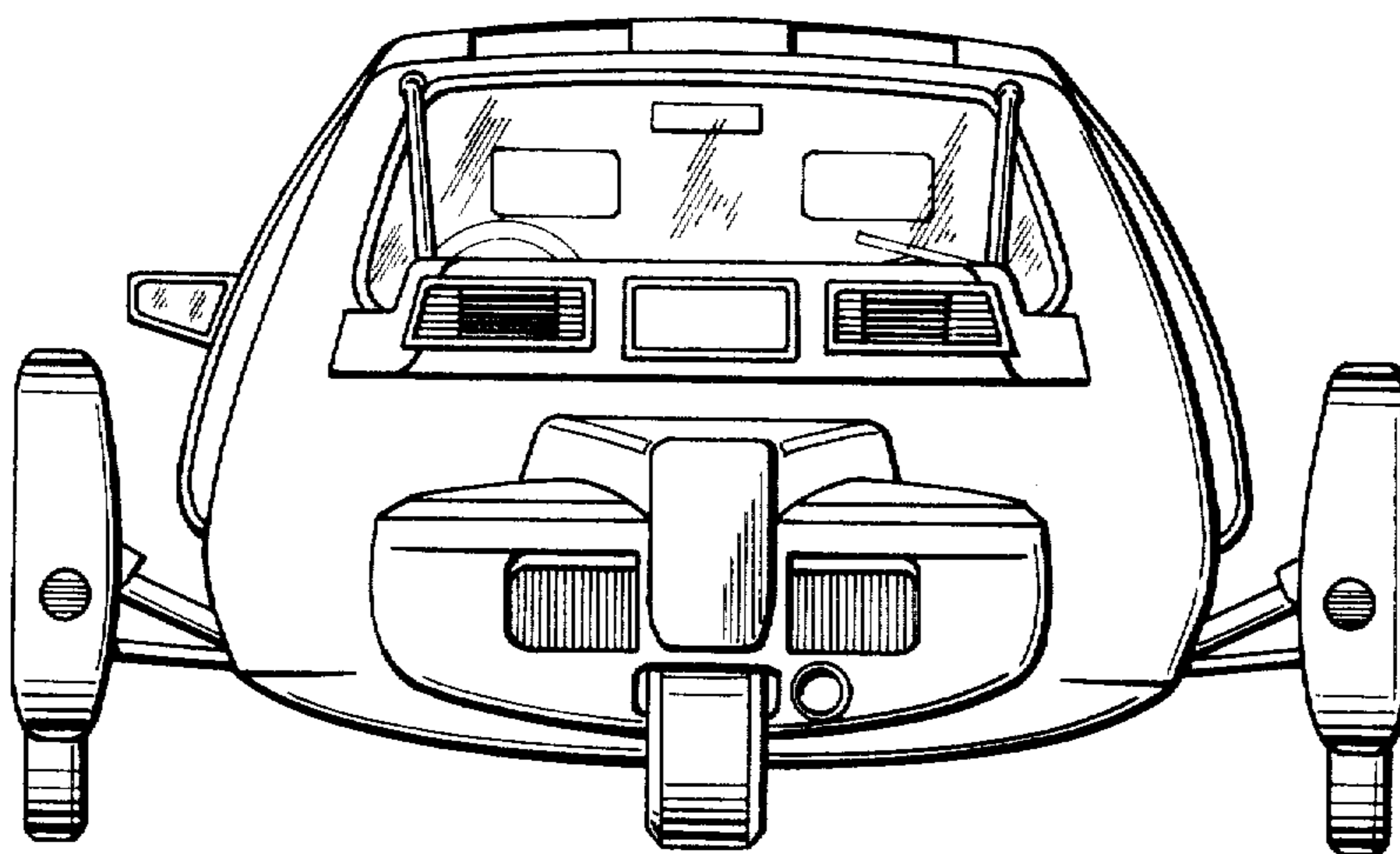
*Fig. 1*



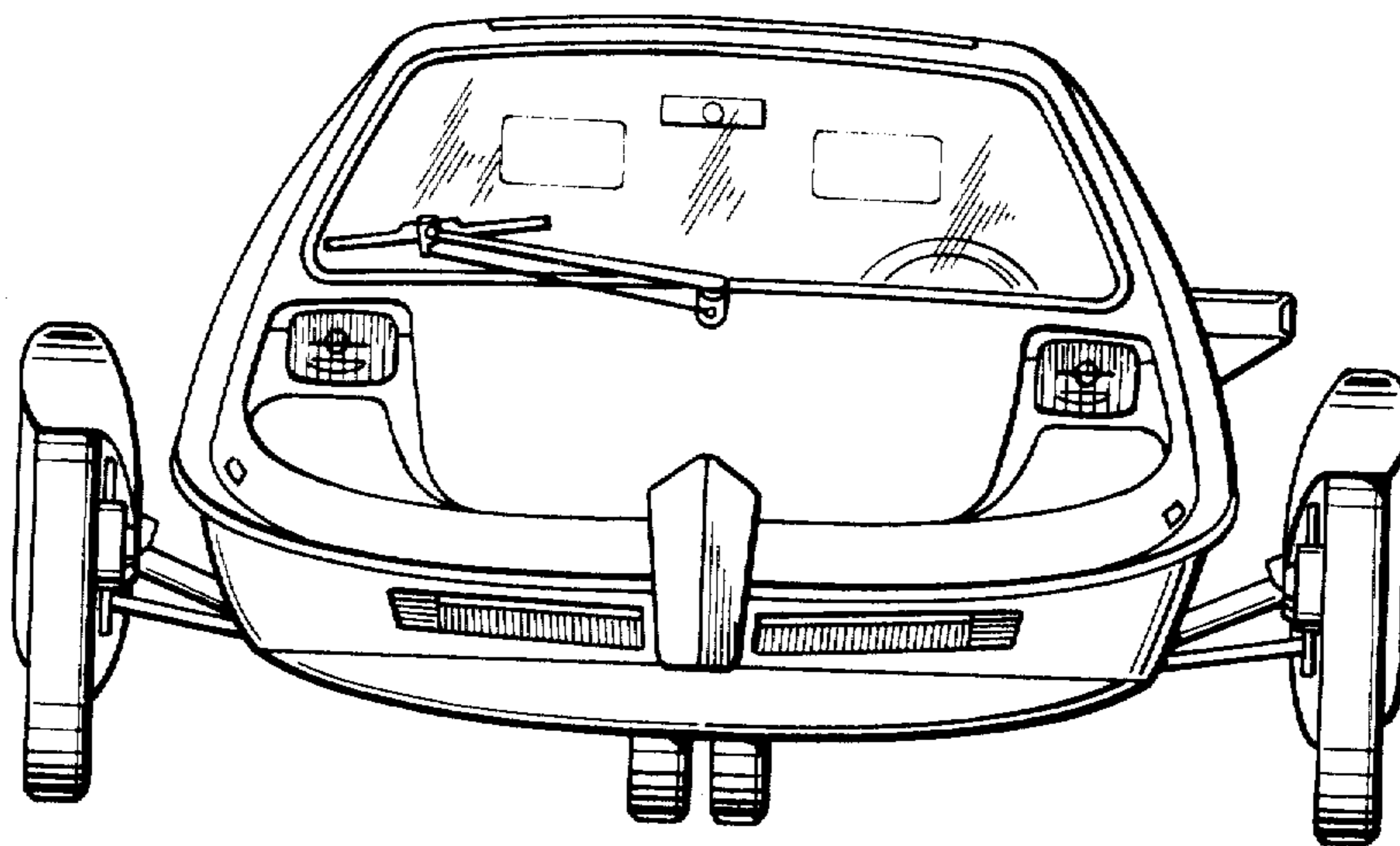
*Fig. 2*



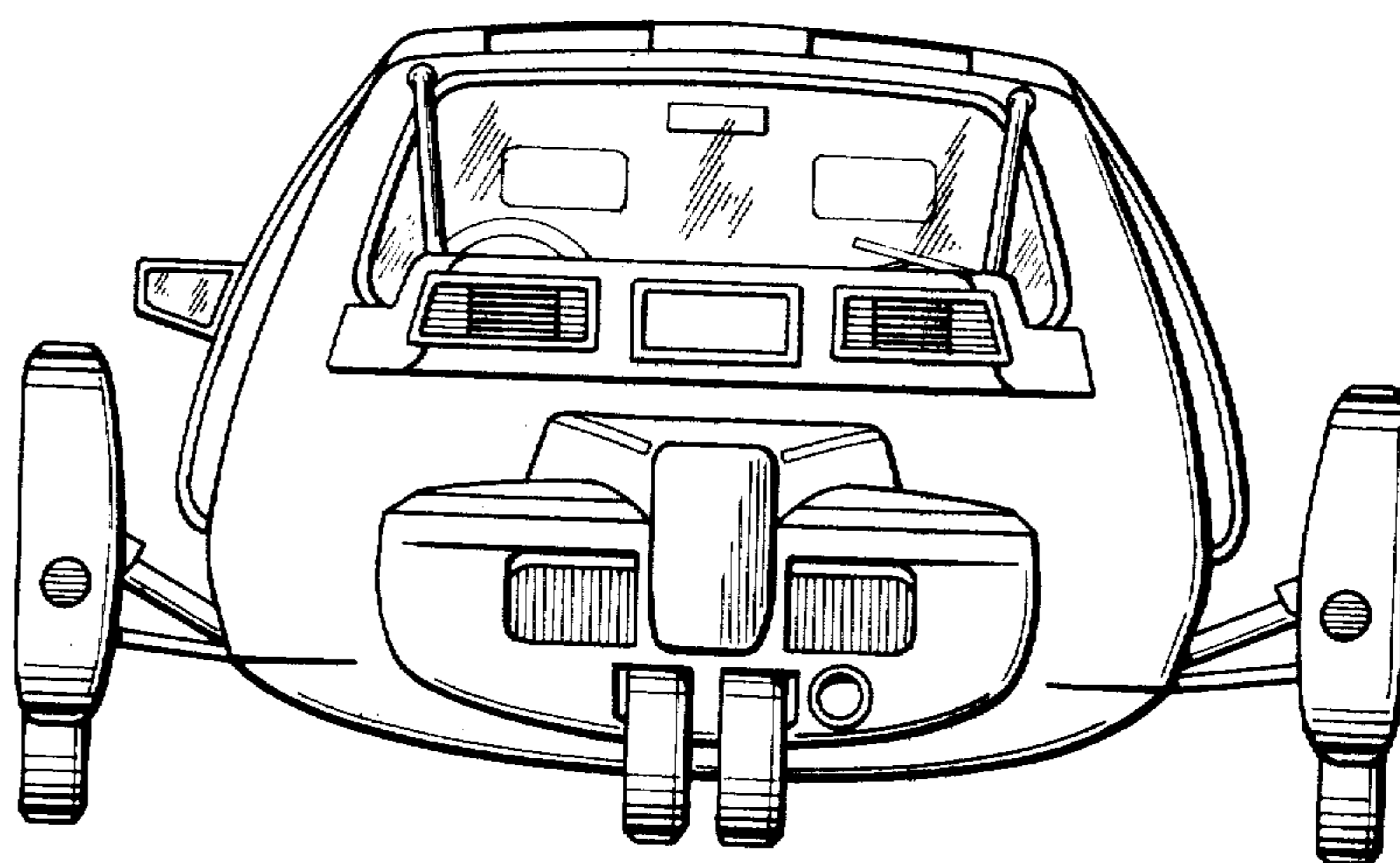
*Fig. 3*



*Fig. 4*



*Fig. 5*



*Fig. 6*