

[54] BOAT SAFETY MAIN SWITCH

[75] Inventor: Leroy F. Hollenbeck, Jr., Miami, Fla.

[73] Assignee: Perko, Inc., Miami, Fla.

[**] Term: 14 Years

[21] Appl. No.: 68,814

[22] Filed: Aug. 22, 1979

[51] Int. Cl. D13-03

[52] U.S. Cl. D13/32

[58] Field of Search 200/42 R, 44, 45, 155;
D13/32

[56] References Cited

U.S. PATENT DOCUMENTS

- D. 55,820 7/1920 Rogers et al. D13/32
- D. 213,698 4/1969 Pelletier D13/32

OTHER PUBLICATIONS

Goldberg's Marine Catalog 1978, C. 1977, p. 119, Item J, Battery Switch.

Primary Examiner—A. Hugo Word
Attorney, Agent, or Firm—Jackson and Wells

[57] CLAIM

The ornamental design for a boat safety main switch, as shown.

DESCRIPTION

FIG. 1 is a top plan view of a boat safety main switch showing my new design;
 FIG. 2 is a rear elevational view thereof;
 FIG. 3 is a right side elevational view thereof;
 FIG. 4 is a bottom plan view thereof;
 FIG. 5 is a front elevational view thereof; and
 FIG. 6 is a left side elevational view thereof.

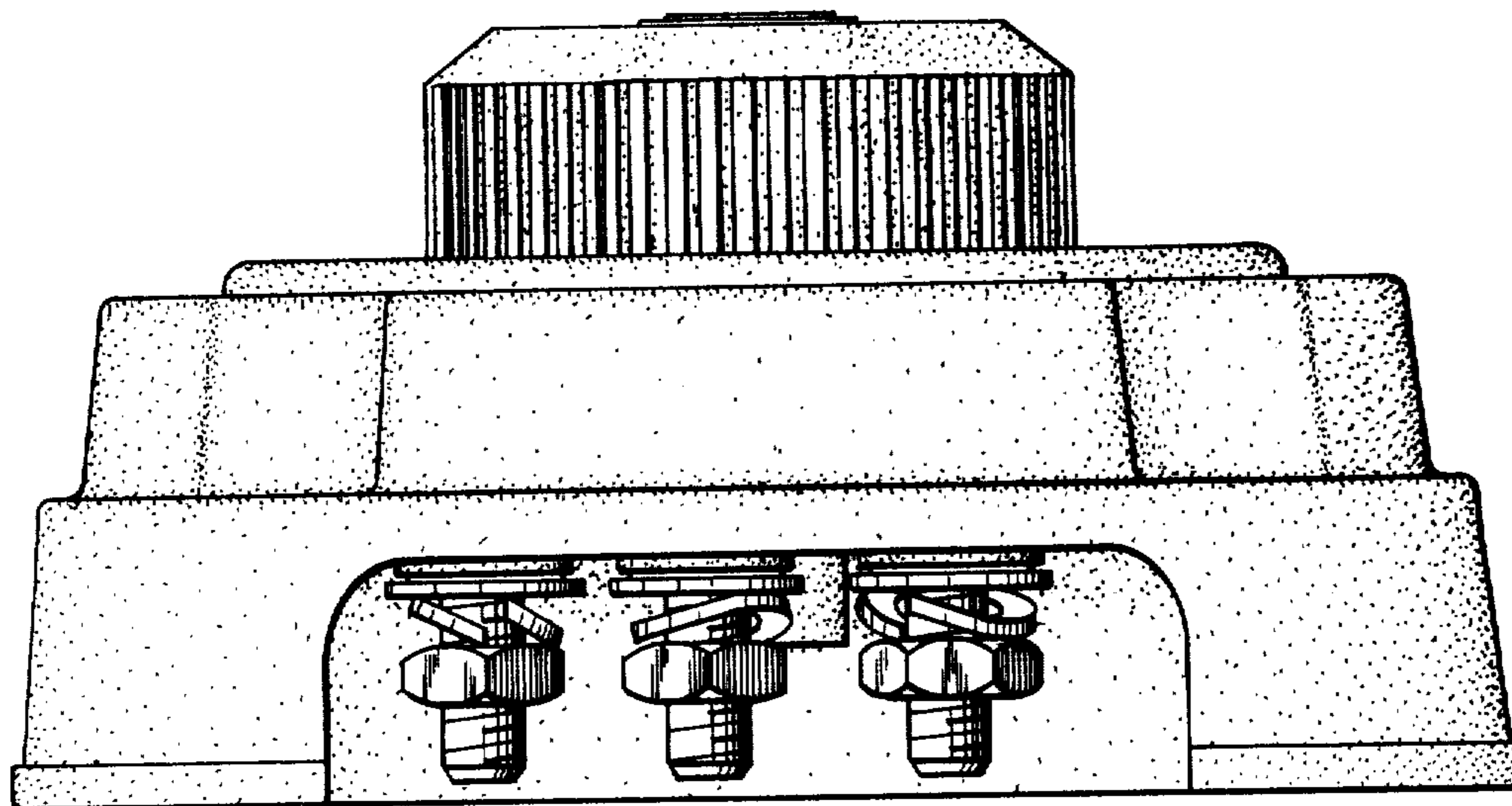

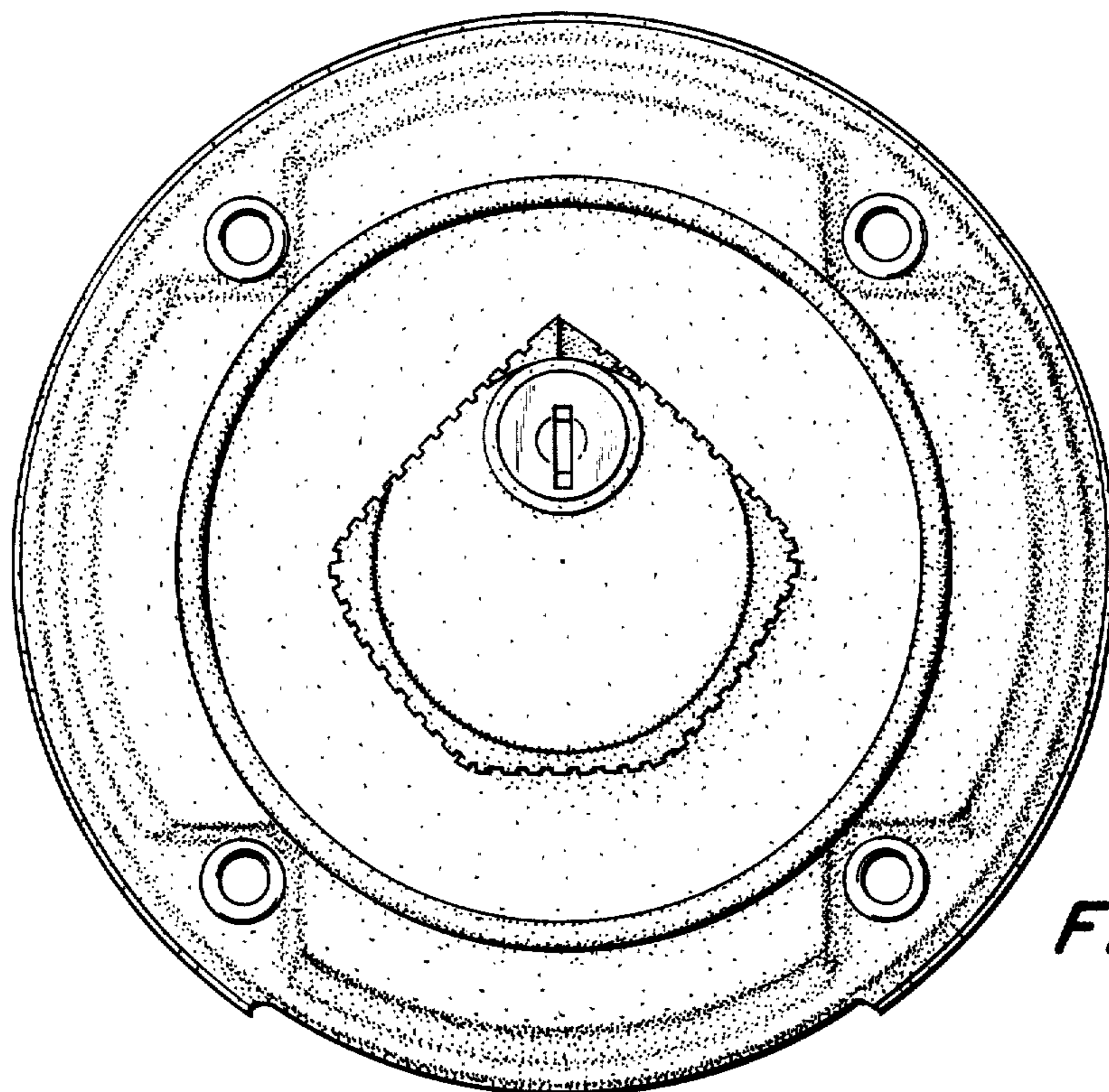

FIG. 1

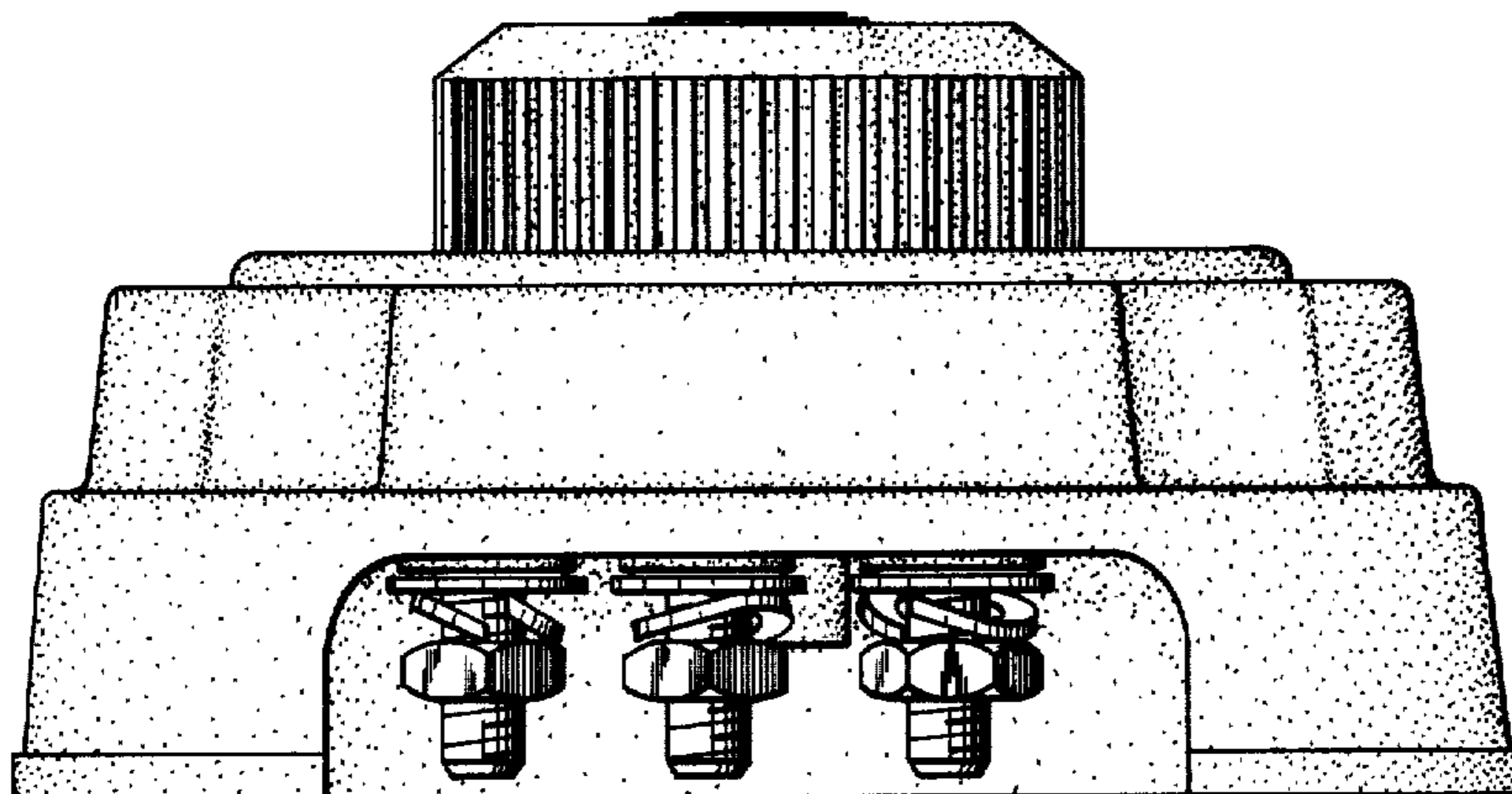

FIG. 2

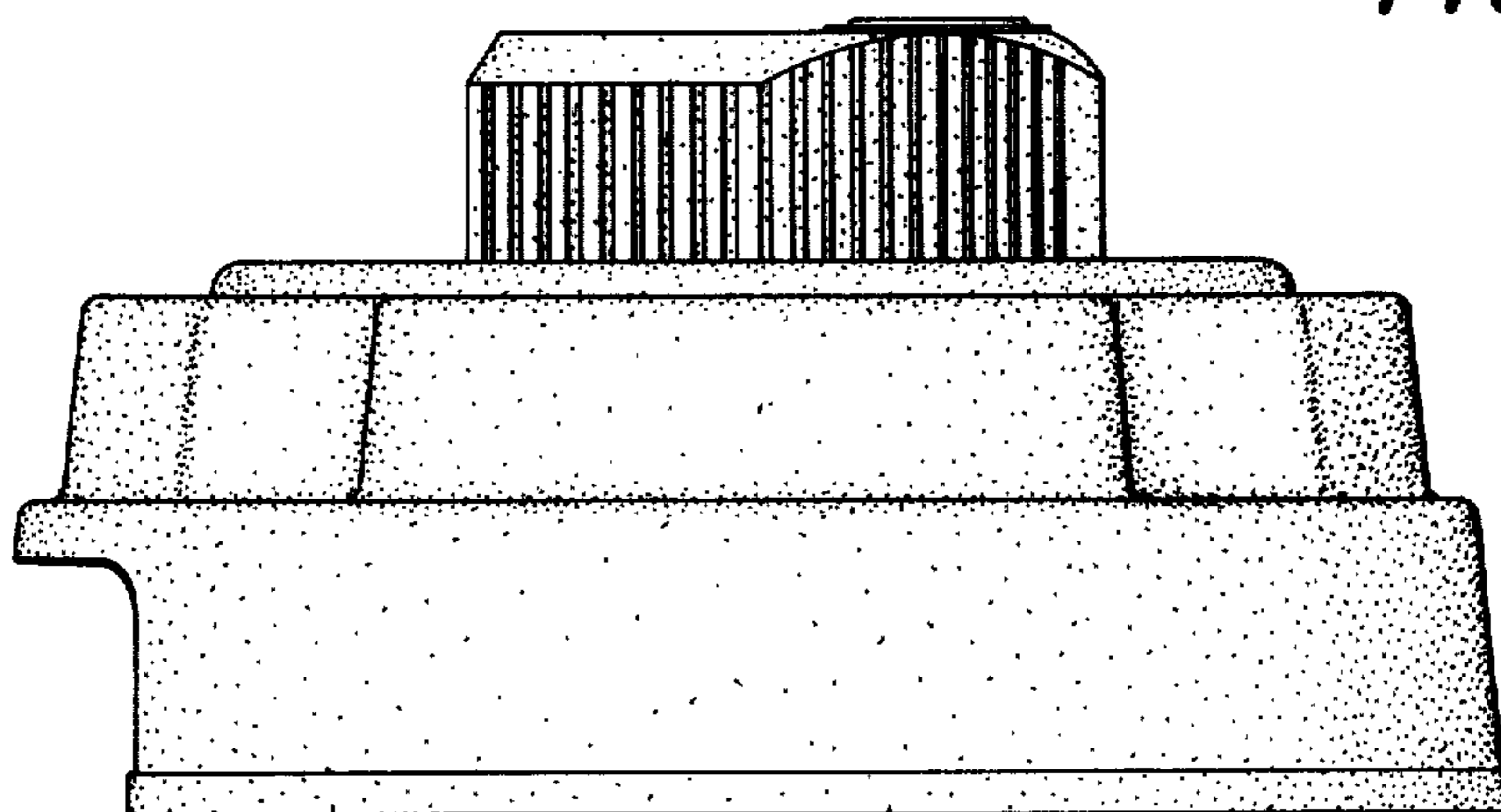

FIG. 3

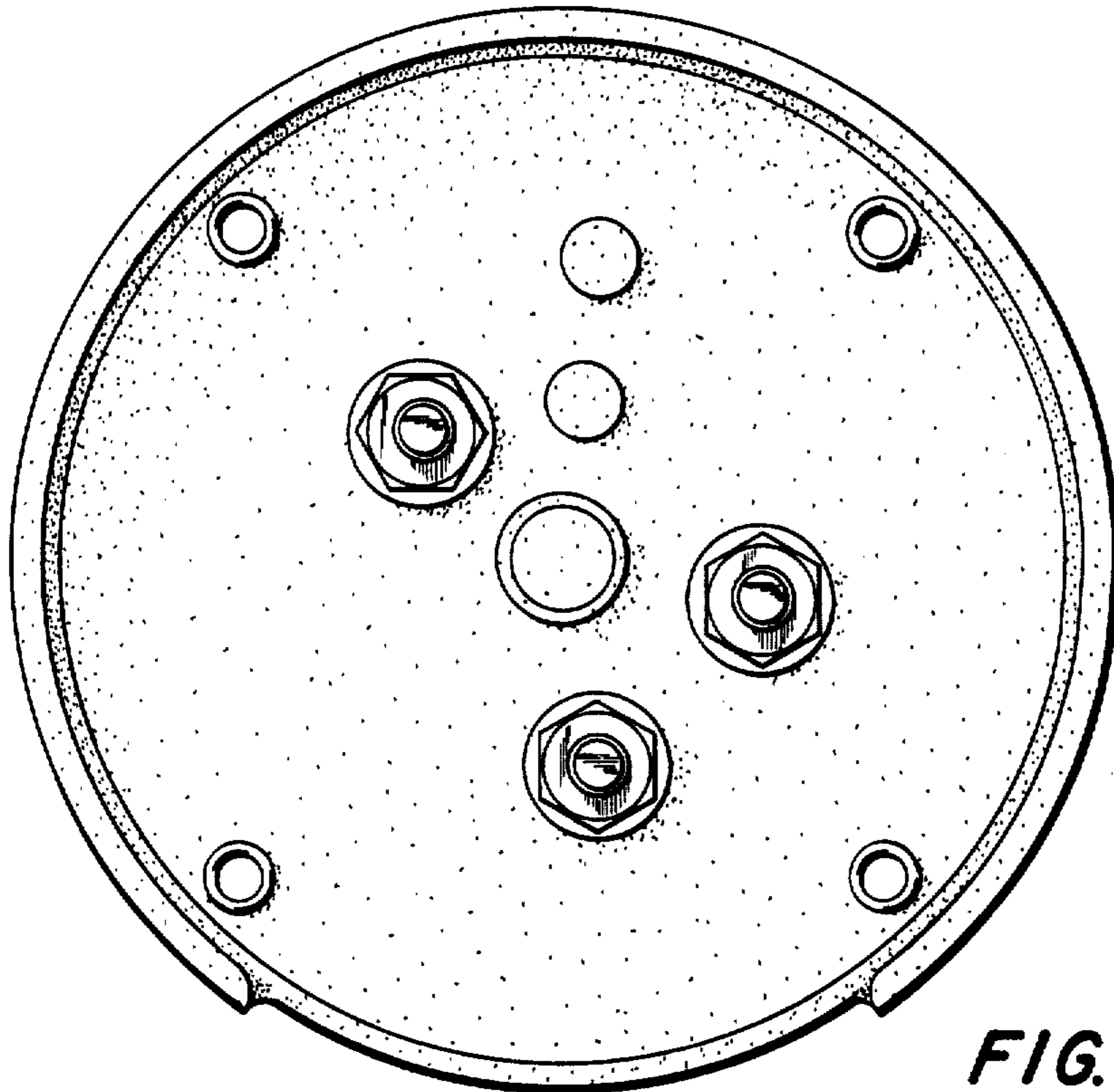

FIG. 4

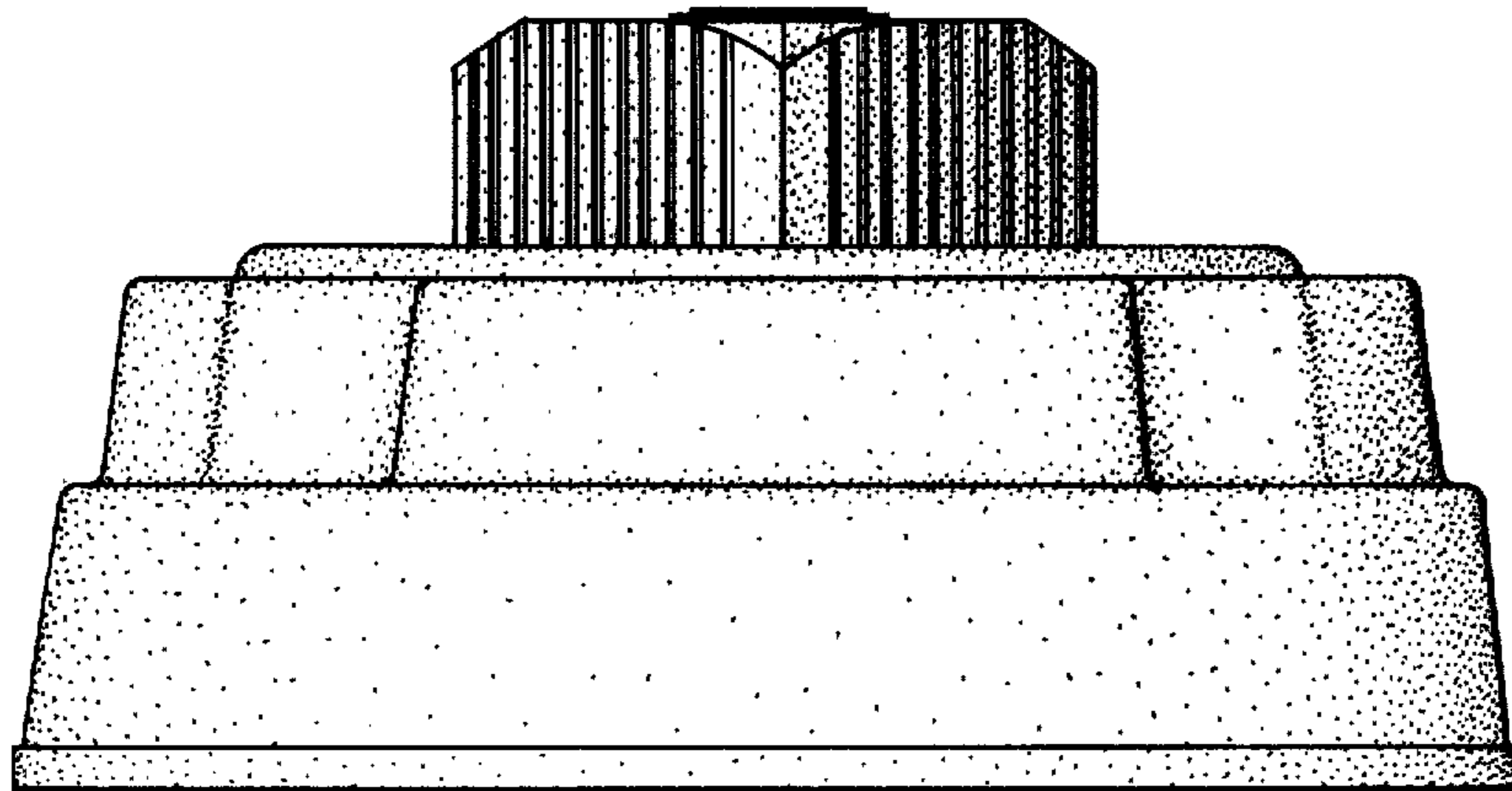

FIG. 5

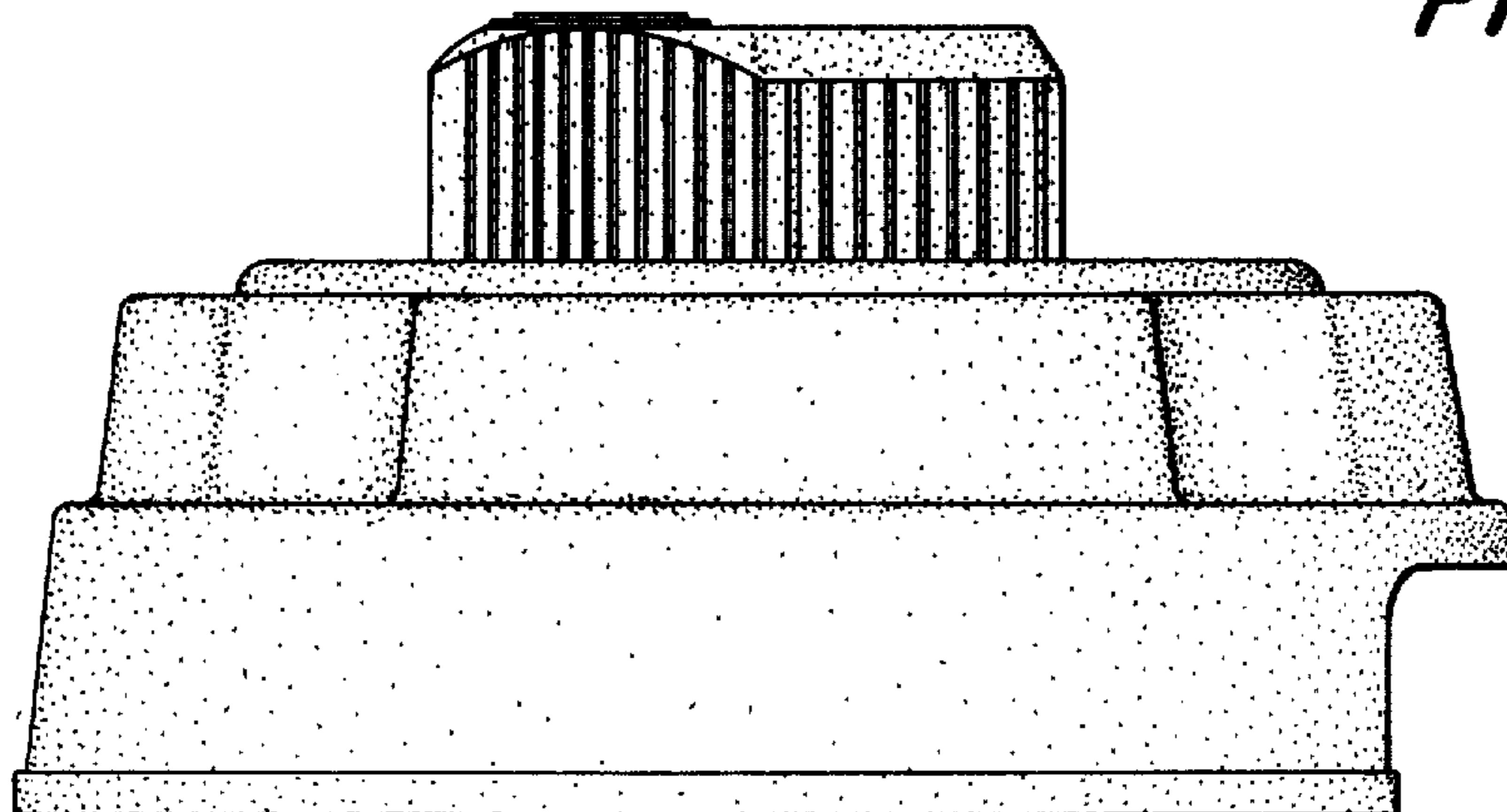

FIG. 6