

- [54] **SIDE RAIL FOR A LAND VEHICLE LUGGAGE RACK**
- [75] Inventor: Daniel J. Kowalski, Ortonville, Mich.
- [73] Assignee: Four Star Corporation, Troy, Mich.
- [**] Term: 14 Years
- [21] Appl. No.: 19,274
- [22] Filed: Mar. 9, 1979
- [51] Int. Cl. D12-16
- [52] U.S. Cl. D12/157; D25/74
- [58] Field of Search D12/157; D25/74, 79; 224/309, 310

- [56] **References Cited**
- U.S. PATENT DOCUMENTS**
- 4,175,682 11/1979 Bott 224/309
- OTHER PUBLICATIONS**
- Anchor Extruded Plastics Catalog, ©1960, p. 40, Ex-

trusion No. 9TR-16, second shape in from bottom left side of page.

Primary Examiner—James M. Gandy
Attorney, Agent, or Firm—Reising, Ethington, Barnard, Perry & Brooks

[57] **CLAIM**

The ornamental design for a side rail for a land vehicle luggage rack, as shown and described.

DESCRIPTION

FIG. 1 is a perspective view of the side rail for a land vehicle luggage rack showing my new design; FIG. 2 is a side elevational view hereof; FIG. 3 is a front elevational view hereof; FIG. 4 is a rear elevational view hereof; FIG. 5 is a bottom plan view hereof; FIG. 6 is a top plan view hereof; FIG. 7 is a perspective view of a side rail for a land vehicle luggage rack showing a second embodiment of my new design; and FIG. 8 is a side elevational view of FIG. 7.

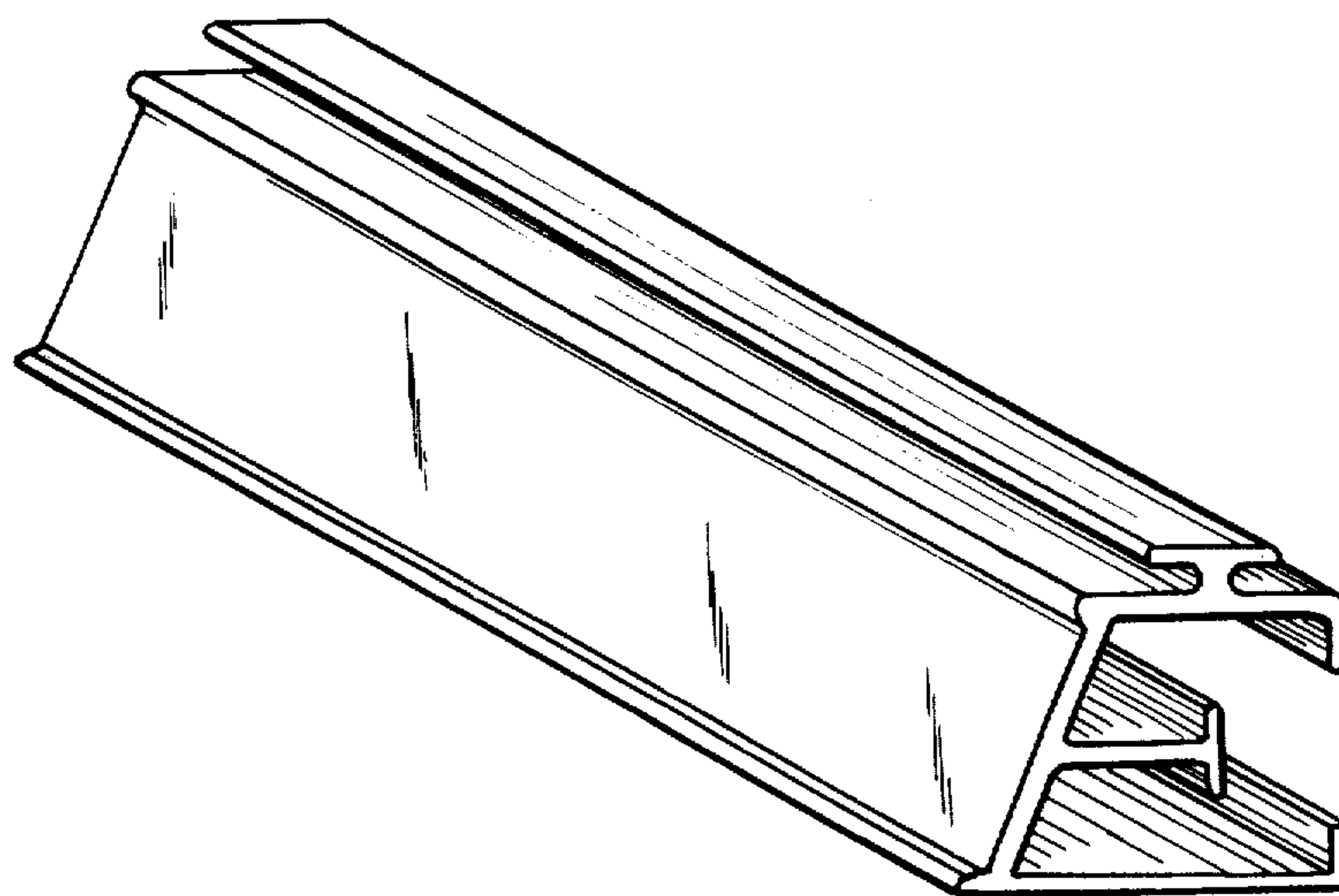

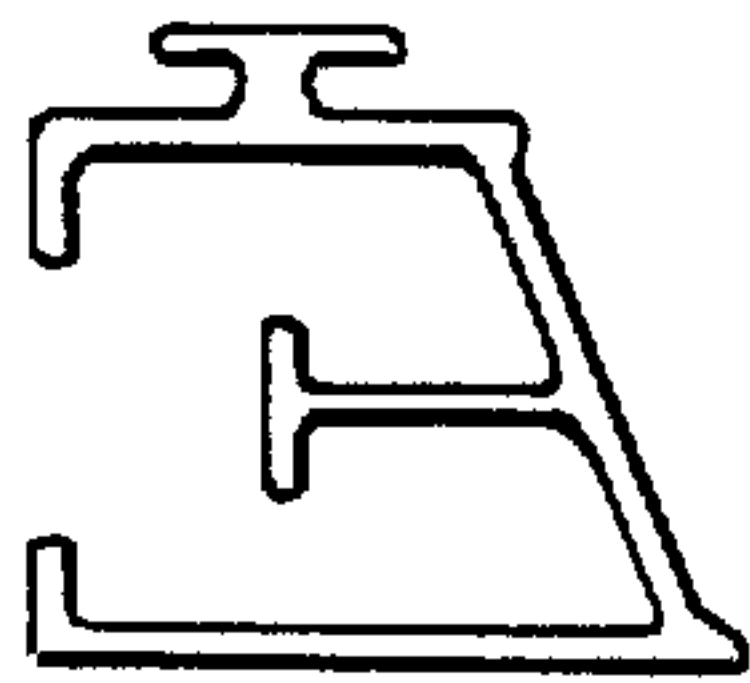

FIG-2

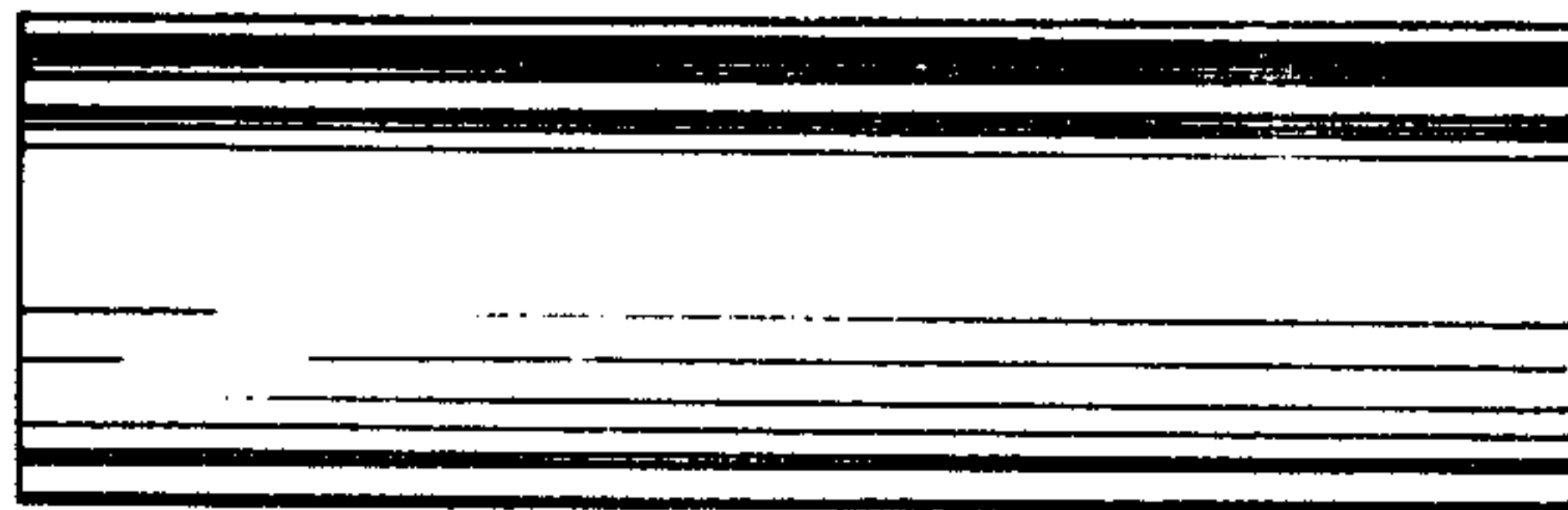

FIG-3

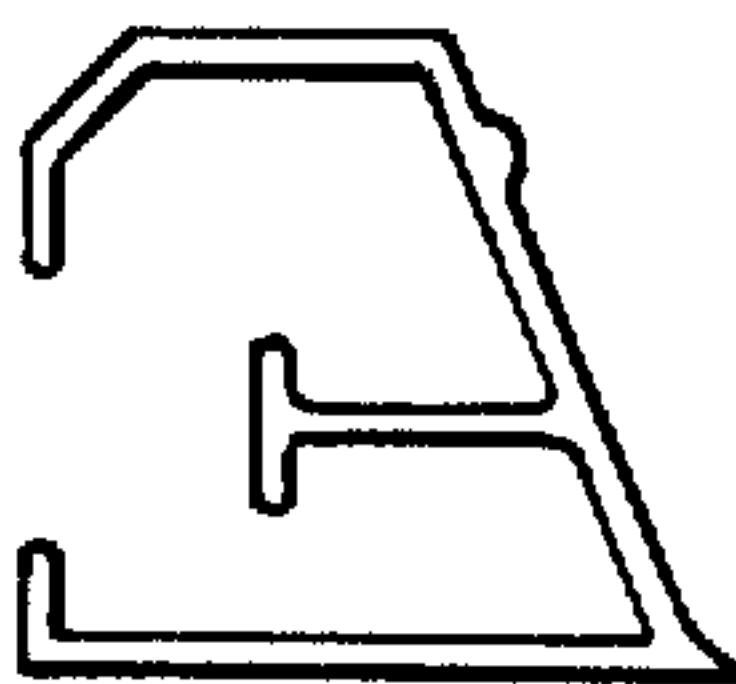

FIG-8

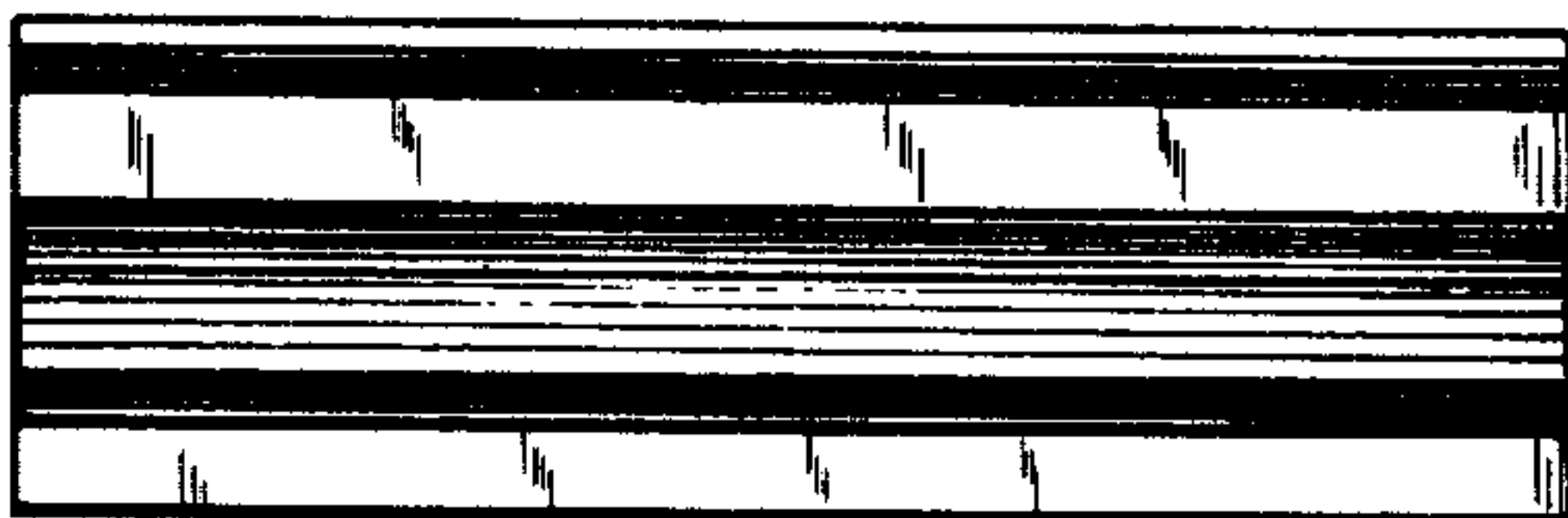

FIG-4

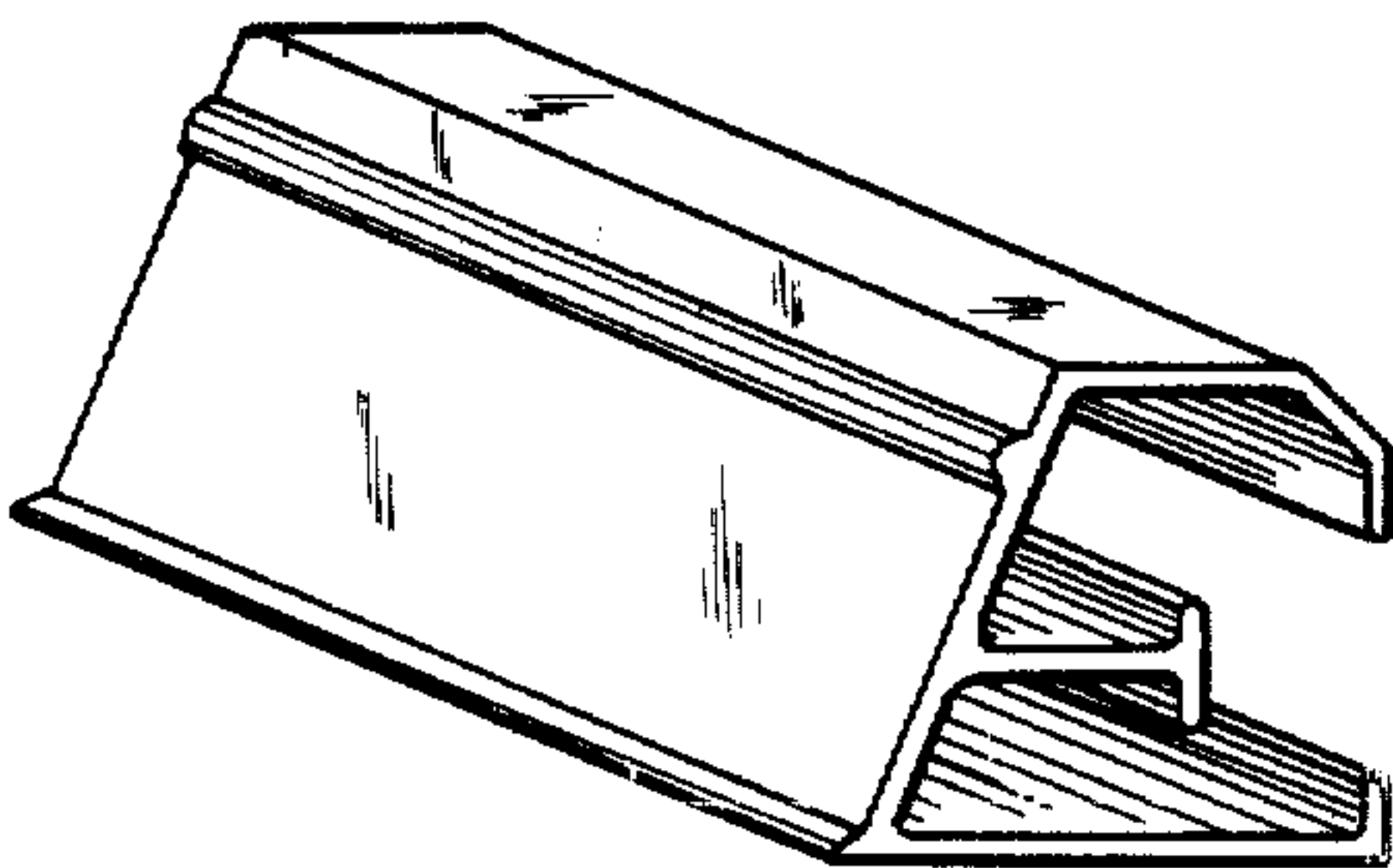

FIG-7

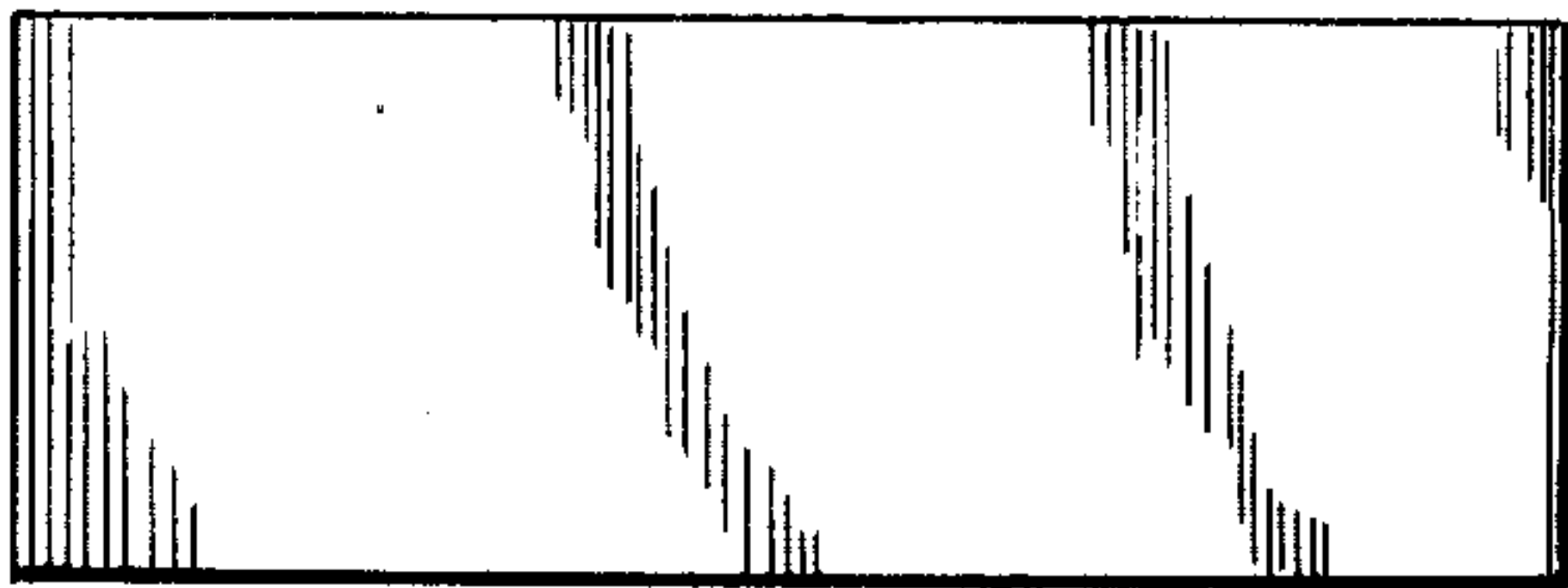

FIG-5

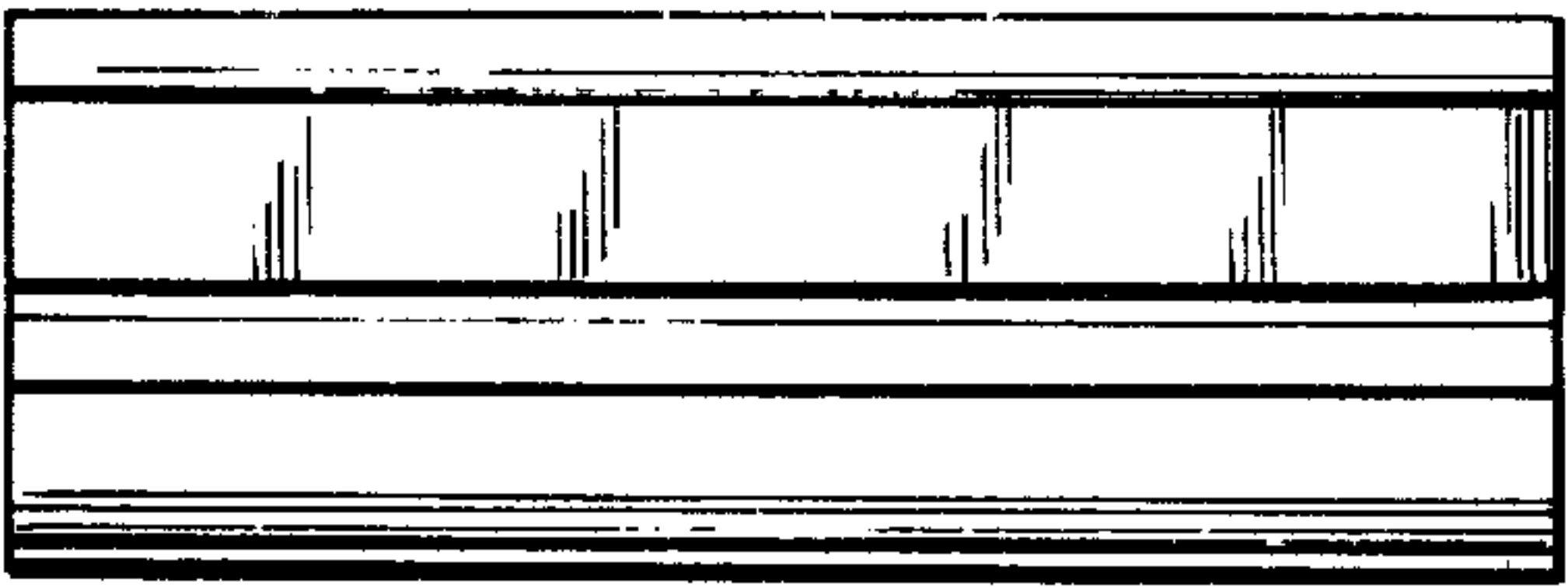

FIG-6

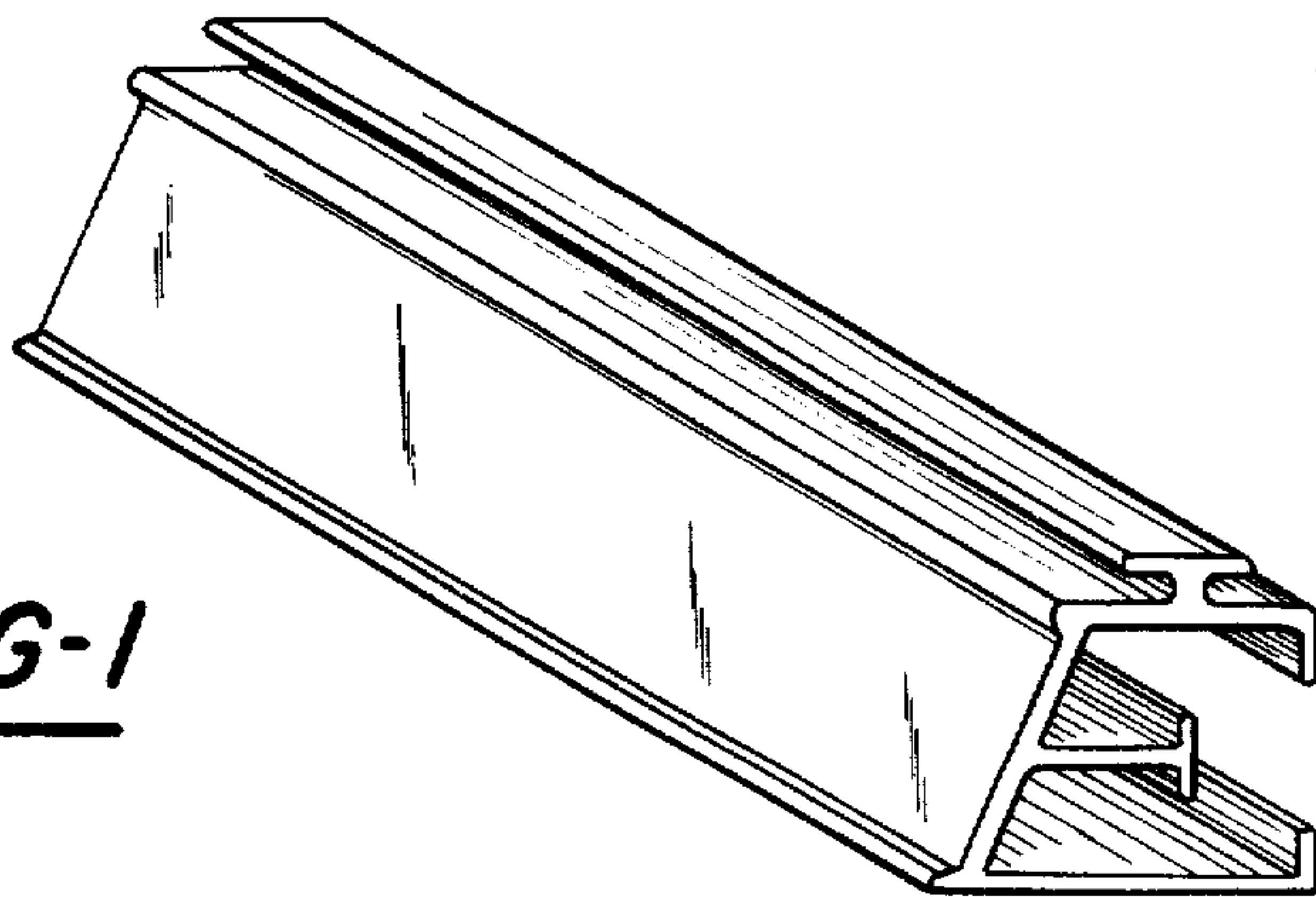

FIG-1