

[54] PORTABLE ELECTRONIC TESTER AND ANALYZER

[75] Inventors: Phillip N. Lawson, II, Anoka; James A. Odom, Jr., Apple Valley, both of Minn.

[73] Assignee: Honeywell Inc., Minneapolis, Minn.

[\*\*] Term: 14 Years

[21] Appl. No.: 96,585

[22] Filed: Nov. 21, 1979

[51] Int. Cl. .... D10-04

[52] U.S. Cl. .... D10/76; D10/46; D10/75; D10/77; D10/78

[58] Field of Search ..... D10/46, 75, 76, 77, D10/78, 79, 80, 81, 83, 99-103; 324/156, 121, 404; 73/431

[56] References Cited

U.S. PATENT DOCUMENTS

- D. 143,796 2/1946 Clement ..... D10/76
- D. 238,562 1/1976 Sylvester ..... D10/46 X

OTHER PUBLICATIONS

*Design News*-5/21/73-p. 140-Impact Analyzer at top-right.

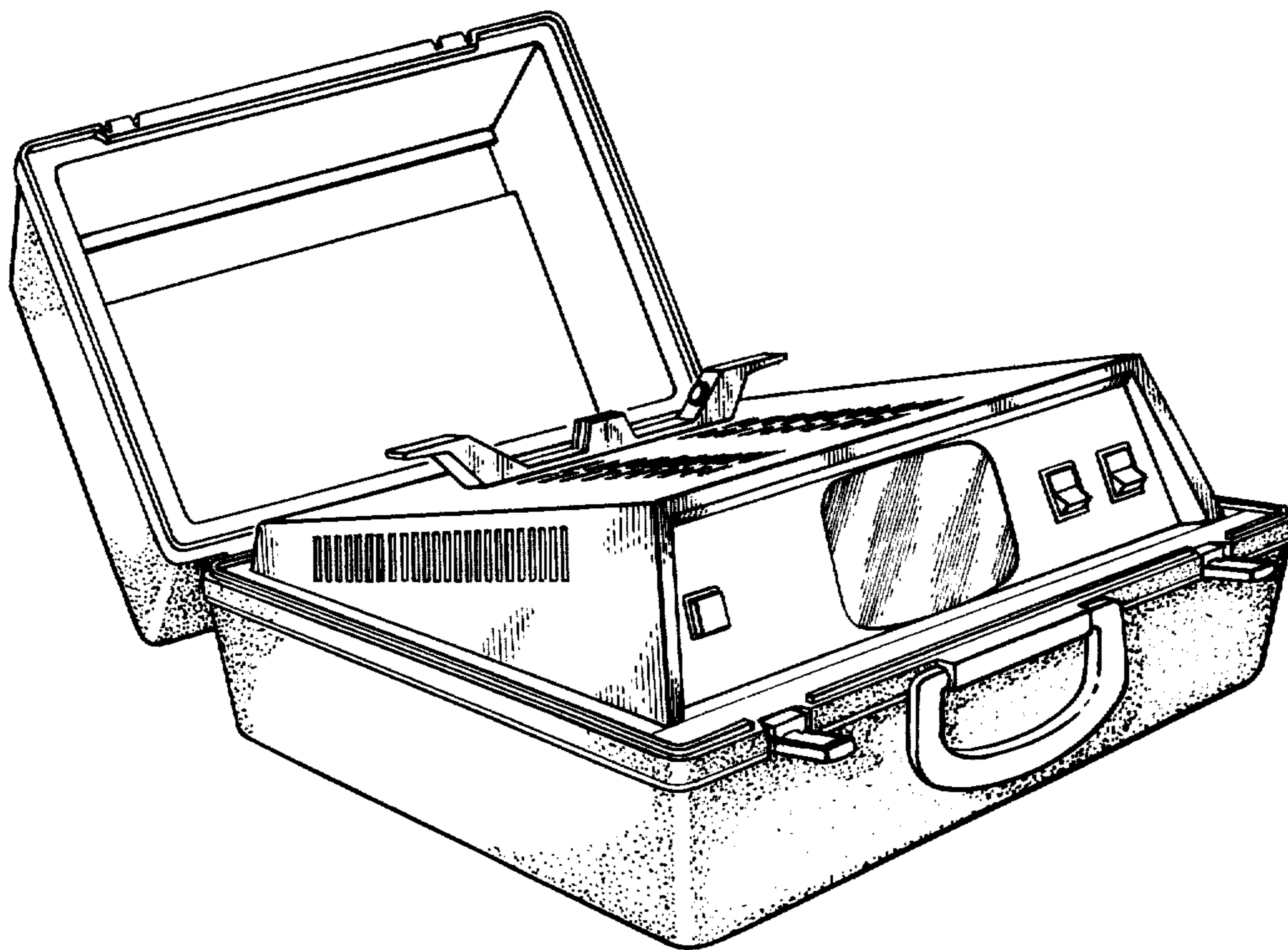
*Primary Examiner*-Nelson C. Holtje  
*Attorney, Agent, or Firm*-Roger W. Jensen

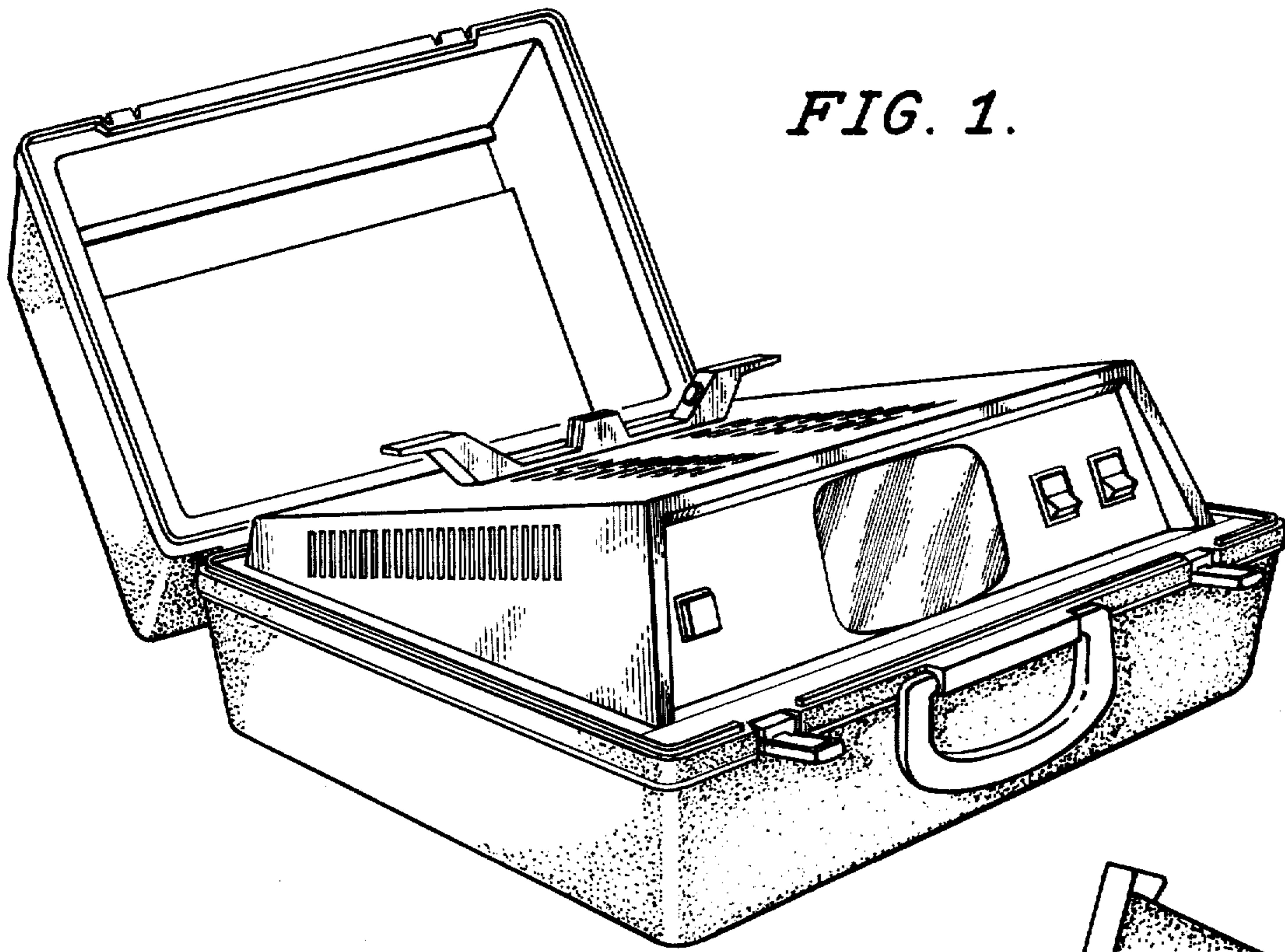
[57] CLAIM

The ornamental design for a portable electronic tester and analyzer, substantially as shown and described.

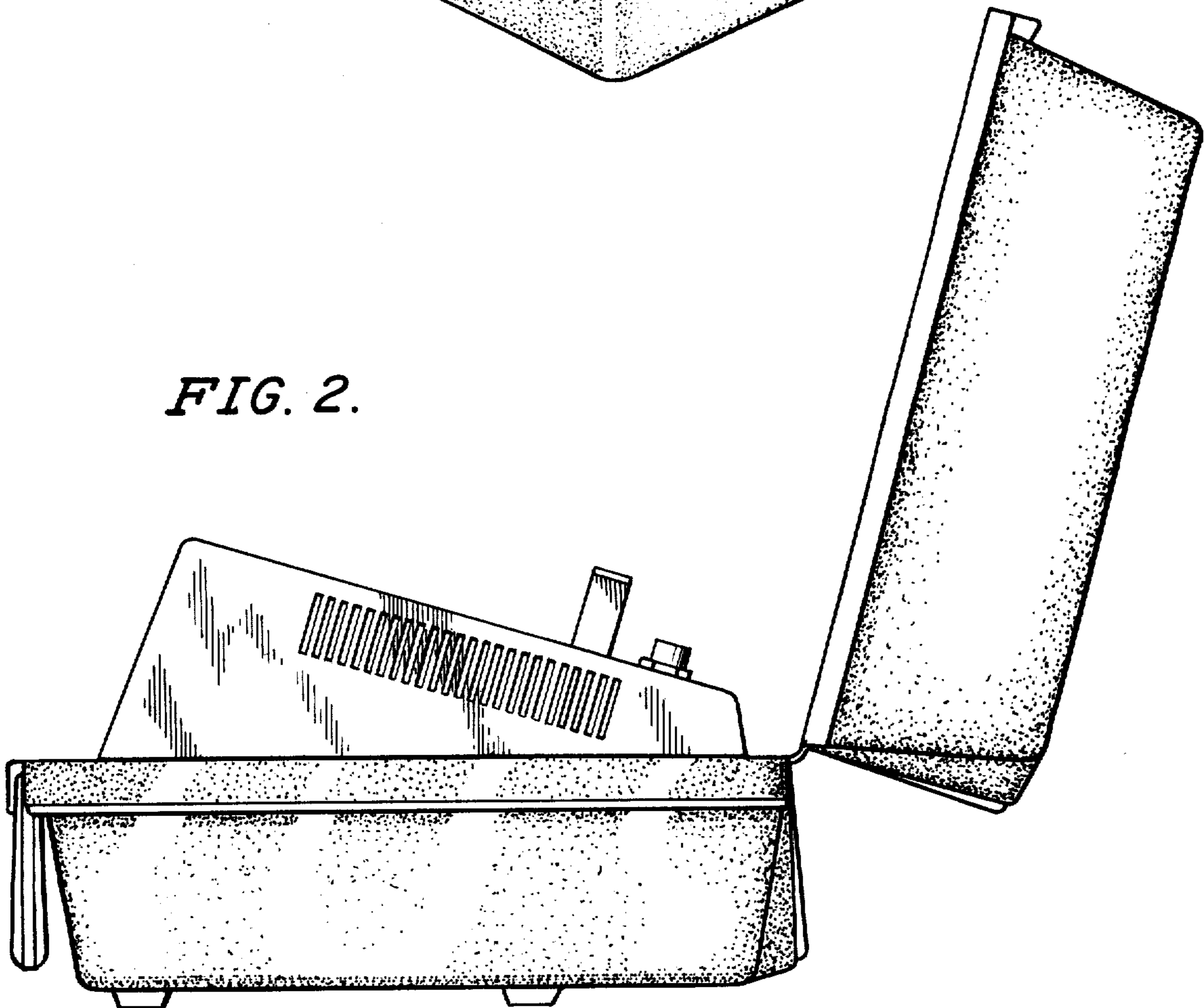
DESCRIPTION

FIG. 1 is a left front perspective view of a portable electronic tester and analyzer showing our new design; FIG. 2 is a right side elevational view thereof; FIG. 3 is a top plan view thereof with portions of the cover omitted for ease of illustration; FIG. 4 is a front elevational view thereof with the cover omitted entirely for ease of illustration; FIG. 5 is a top plan view thereof with the cover in a closed position; FIG. 6 is a rear elevational view thereof with the cover in a closed position.



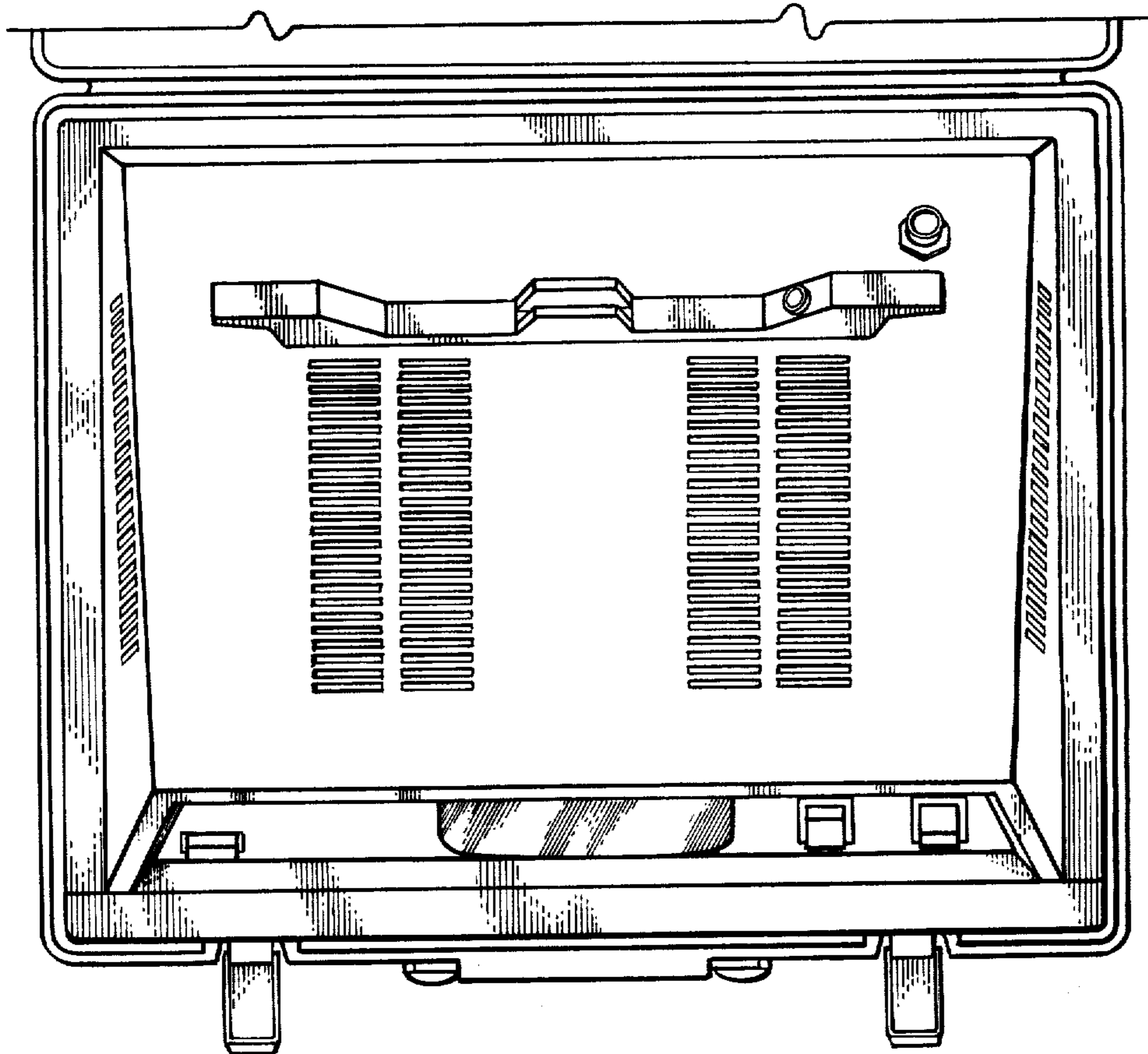


*FIG. 1.*

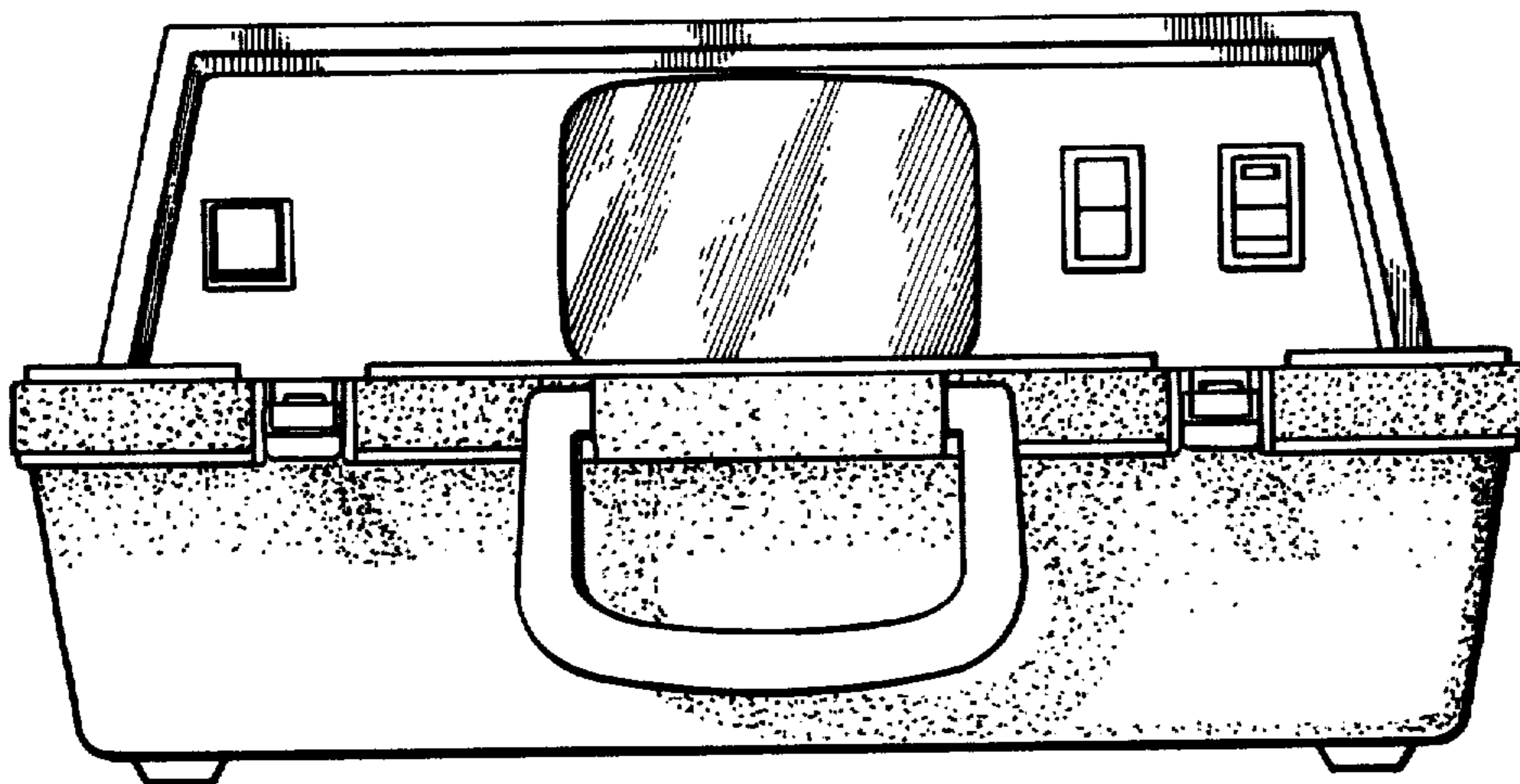


*FIG. 2.*

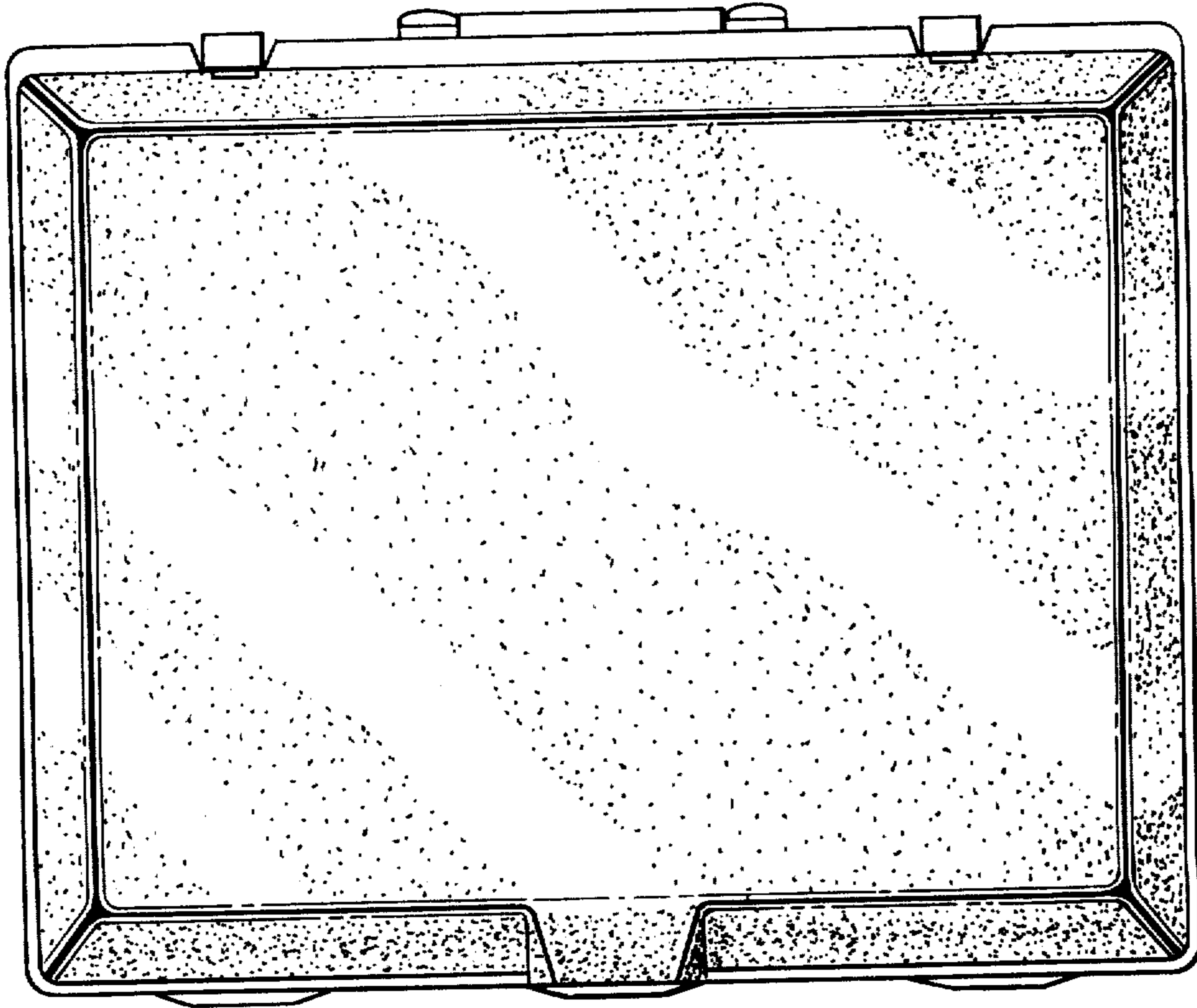
*FIG. 3.*



*FIG. 4.*



*FIG. 5*



*FIG. 6.*

