

[54] MULTI STATION PHYSICAL EXERCISER

[76] Inventor: Lloyd J. Lambert, Jr., 1538 College Ave., South Houston, Tex. 77587

[**] Term: 14 Years

[21] Appl. No.: 948,636

[22] Filed: Oct. 4, 1978

[51] Int. Cl. D21-02

[52] U.S. Cl. D21/195

[58] Field of Search D21/191, 195, 196, 197, D21/198; 272/93, 102, 103, 109, 112, 113, 70.3, 116, 117, 118, 125, 134, 139, 141, 147

[56] References Cited

U.S. PATENT DOCUMENTS

D. 204,397	4/1966	Marcy et al.	D21/195
2,932,509	4/1960	Zinkin	D21/195

OTHER PUBLICATIONS

Marcy Catalog, 1970, p. 49, Multi-Station Weight Training Machine #1304.

Primary Examiner—Charles A. Rademaker
Attorney, Agent, or Firm—Victor J. Evans & Co.

[57] CLAIM

The ornamental design for a multi station physical exerciser, substantially as shown and described.

DESCRIPTION

FIG. 1 is a side elevational view of a multi station physical exerciser showing my new design;
FIG. 2 is a side elevational view of the side opposite that shown in FIG. 1;
FIG. 3 is a right end elevational view thereof;
FIG. 4 is a left end elevational view thereof; and
FIG. 5 is a top plan view thereof.

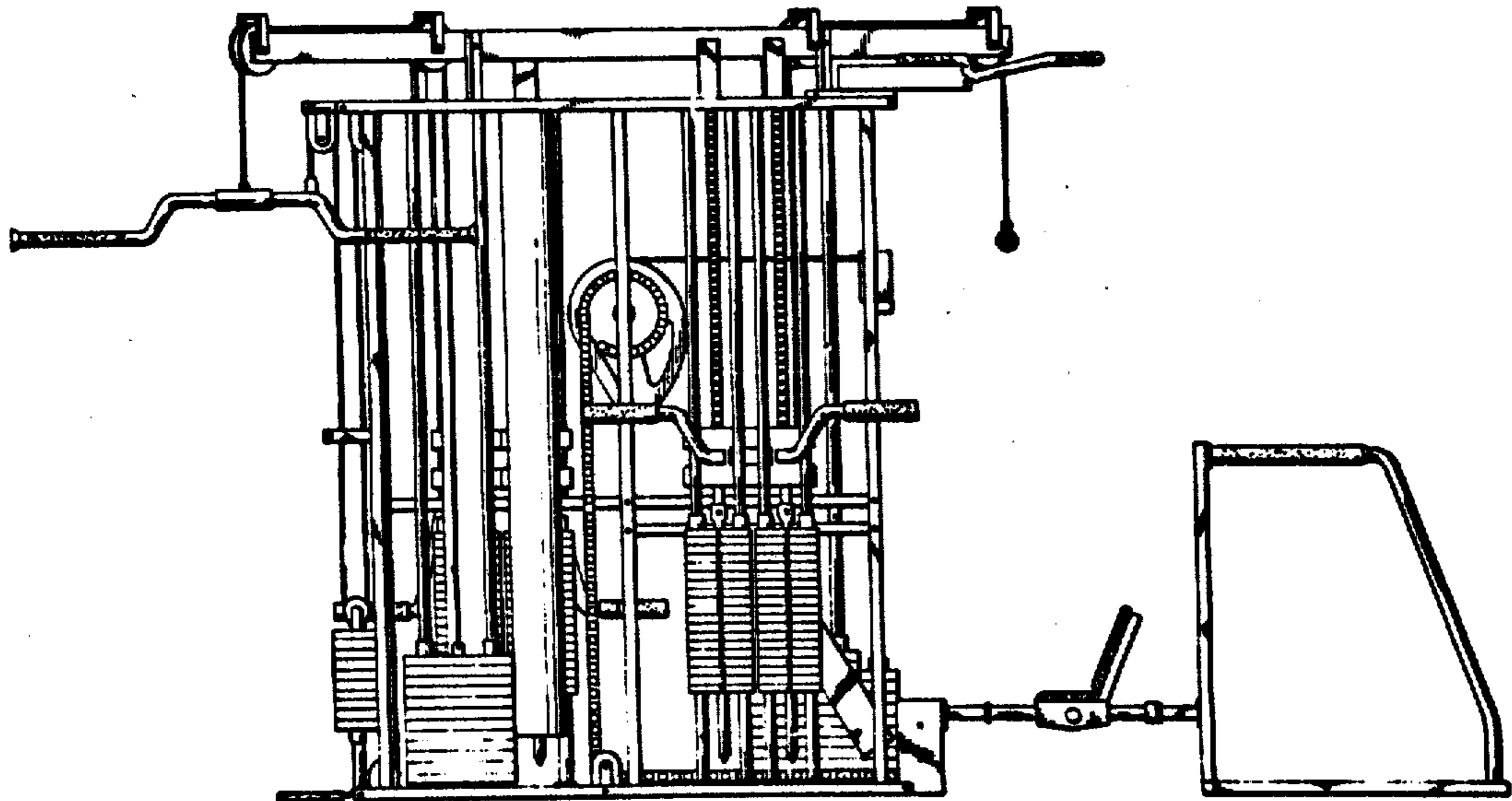

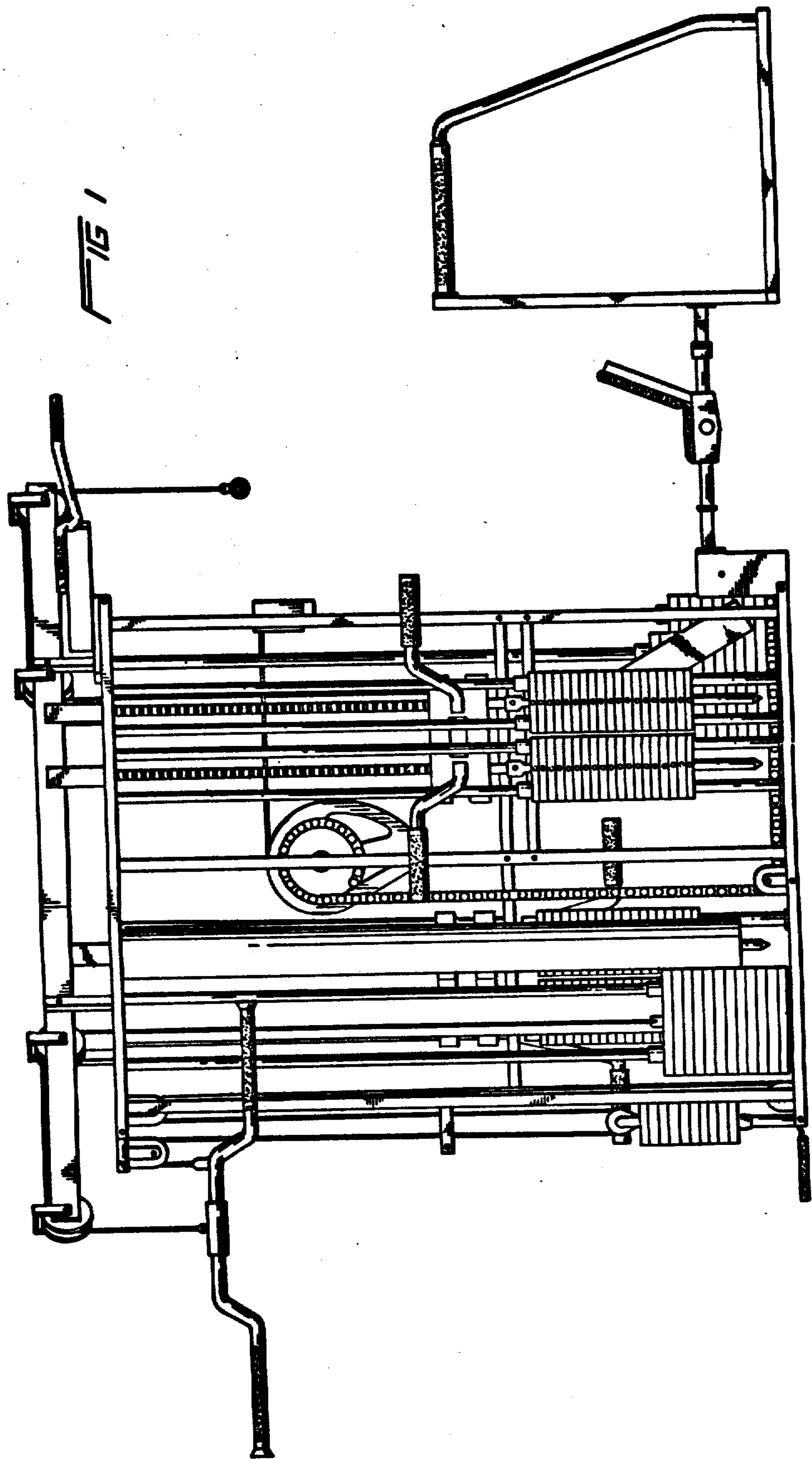

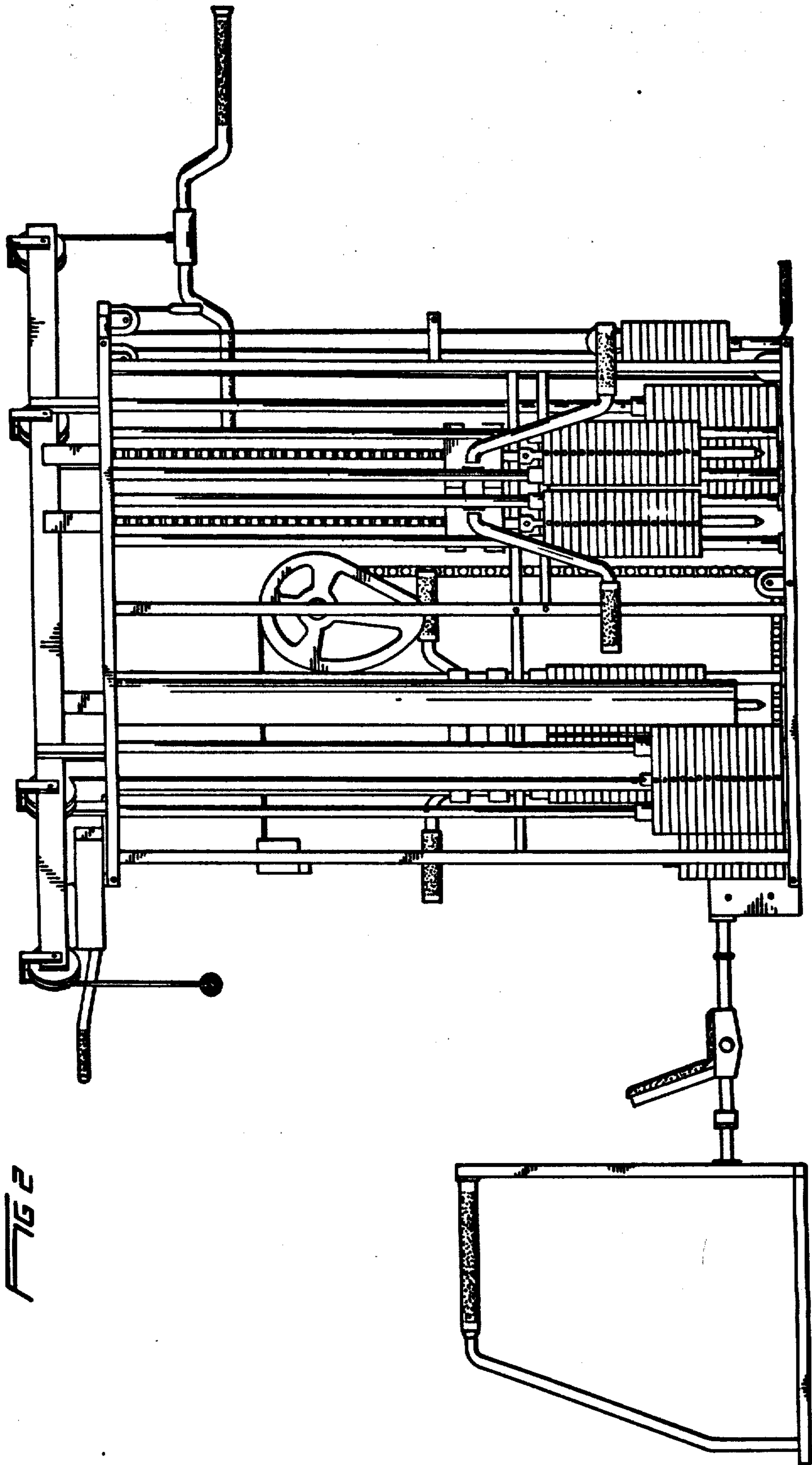

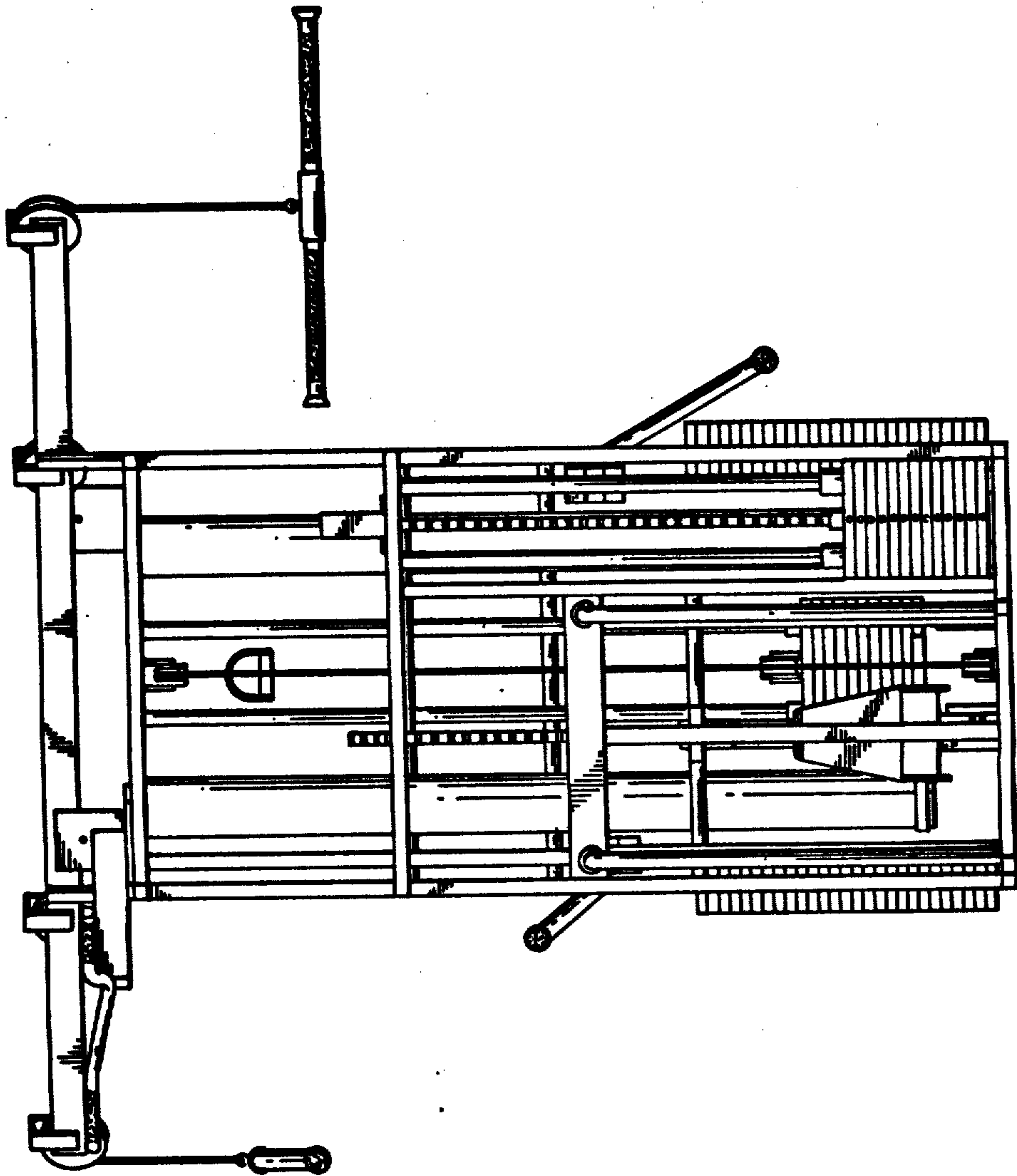

FIG 3

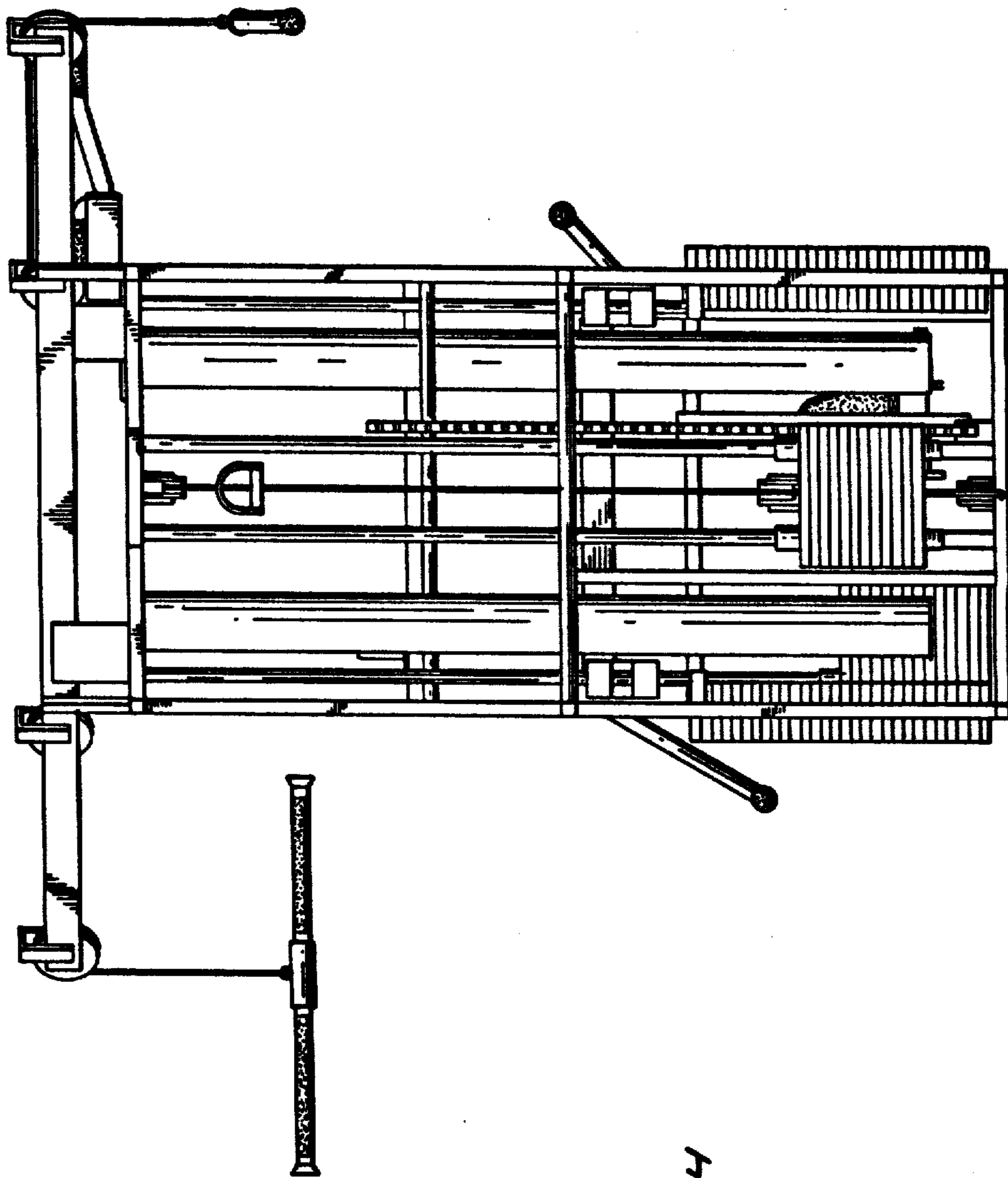

FIG 4

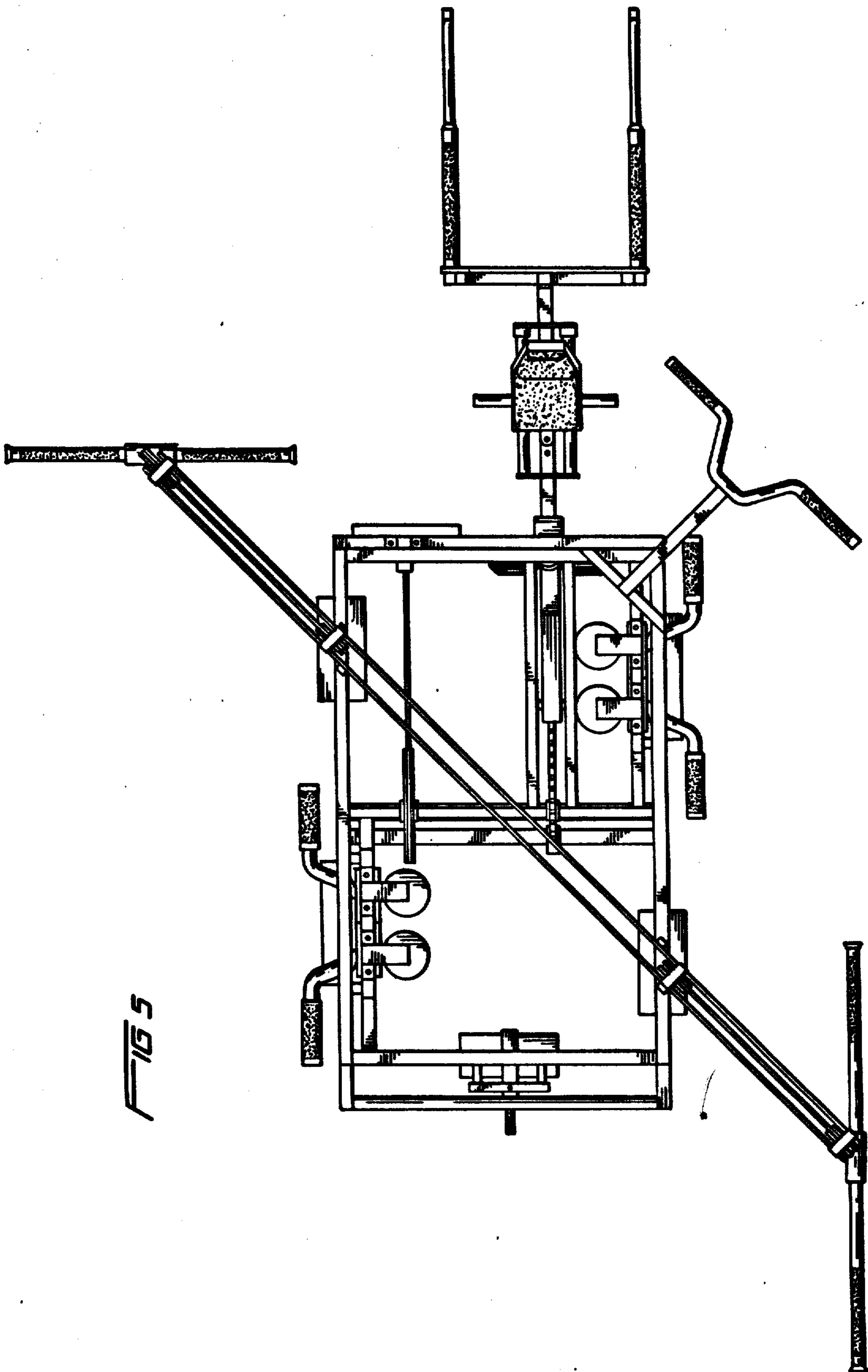

FIG 5