

[54] AUTOMOBILE WHEEL

[75] Inventor: James R. Powers, Los Angeles, Calif.

[73] Assignee: DeLorean Motor Company, Bloomfield Hills, Mich.

[**] Term: 14 Years

[21] Appl. No.: 904,722

[22] Filed: May 10, 1978

[51] Int. Cl. D12-16

[52] U.S. Cl. D12/211

[58] Field of Search D12/209, 211; 301/63 R, 301/63 DD, 63 DT, 63 PW, 64 R, 64 SH, 64 SD, 65, 66

[56] References Cited

U.S. PATENT DOCUMENTS

D. 223,534 5/1972 Reid D12/209

OTHER PUBLICATIONS

Road & Track, 10/75, p. 8, Wheel, center of page.
Motor Trend, 9/77, p. 86, Wheel, center of page.

Primary Examiner—James M. Gandy
Attorney, Agent, or Firm—Reising, Ethington, Barnard, Perry & Brooks

[57] CLAIM

The ornamental design for an automobile wheel, substantially as shown.

DESCRIPTION

FIG. 1 is a side elevational view of my automobile wheel;

FIG. 2 is a sectional view along line 2—2 of FIG. 1;

FIG. 3 is a sectional view along line 3—3 of FIG. 1; and

FIG. 4 is an enlarged perspective view thereof.

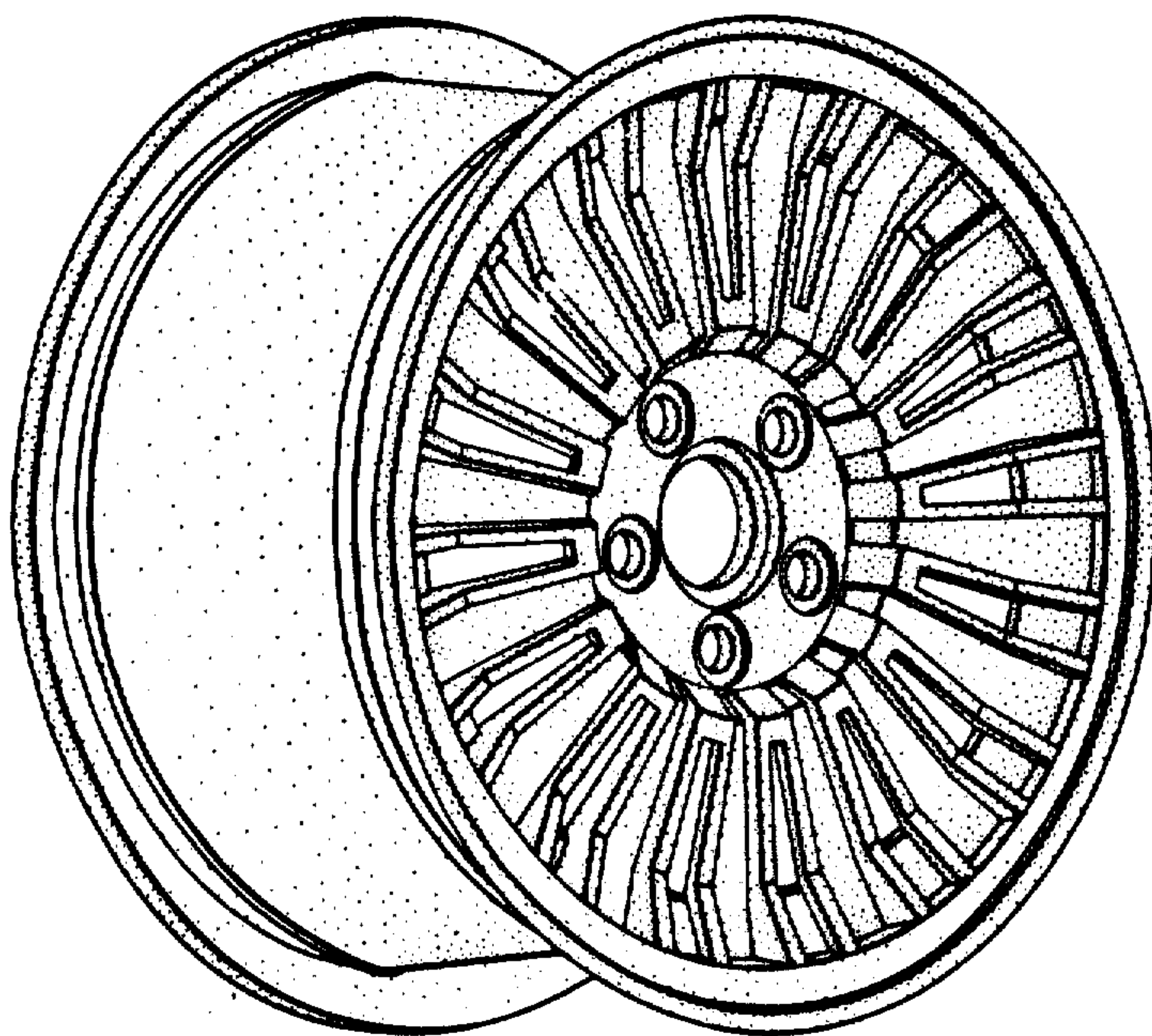

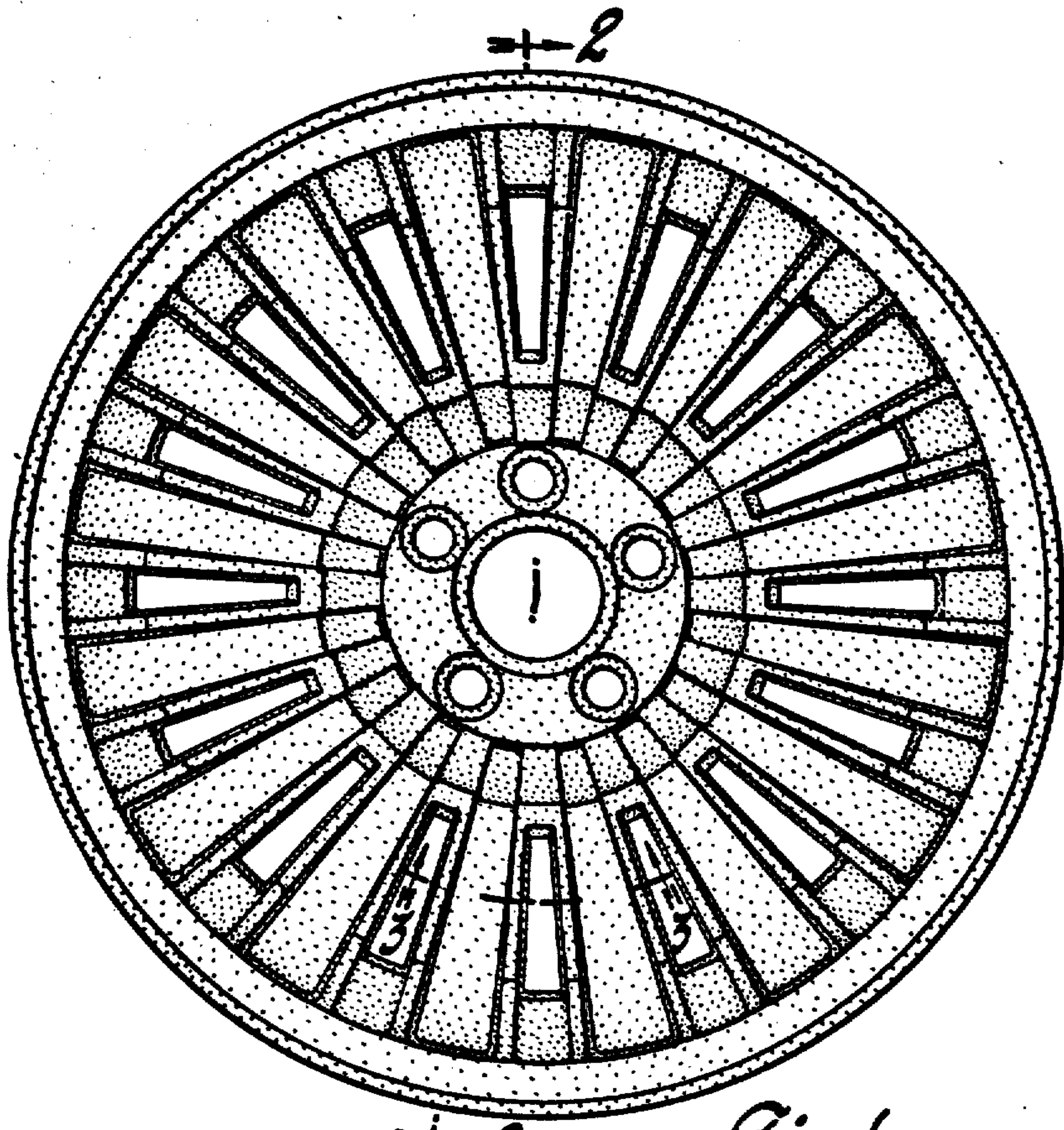

2-2

Fig. 1

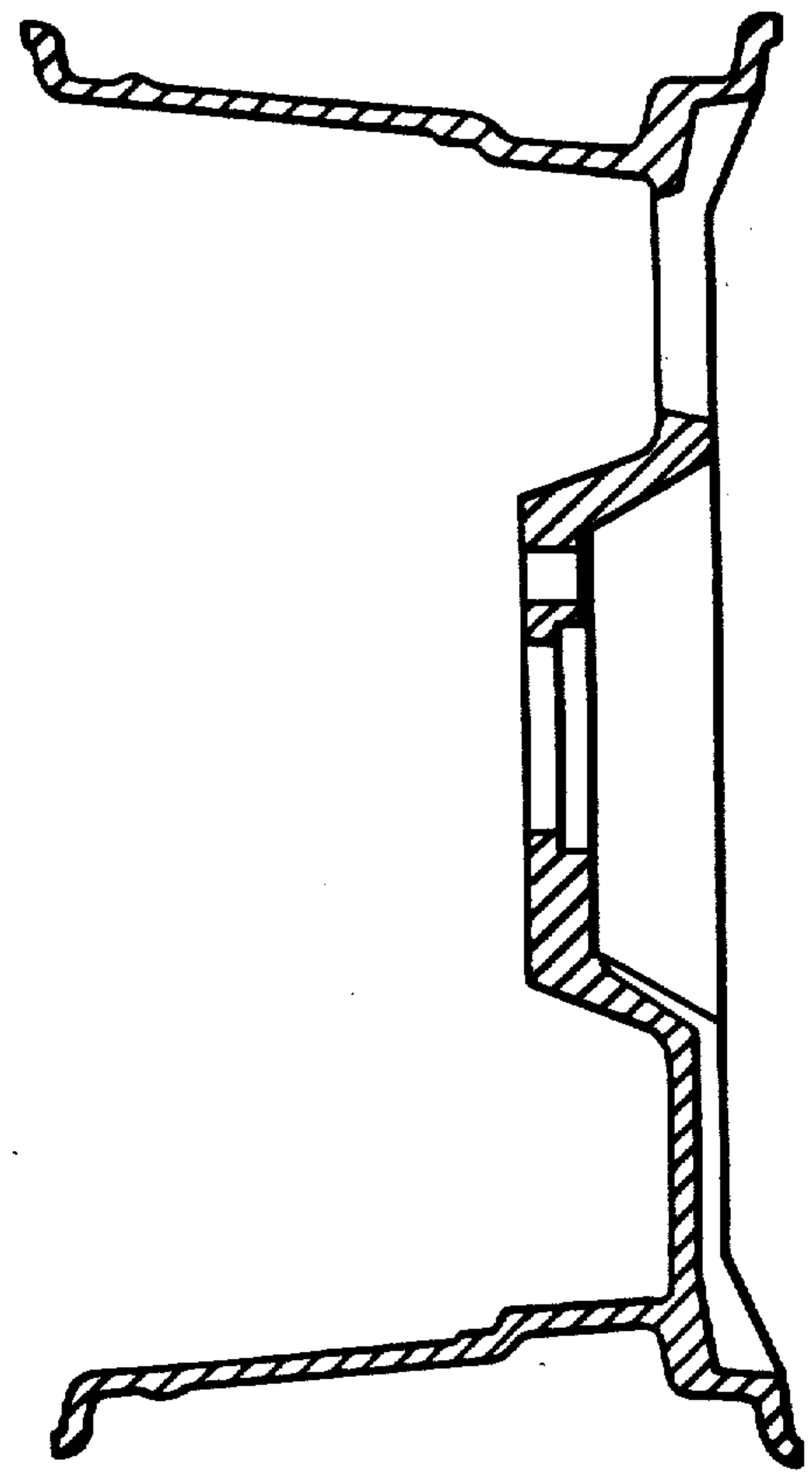

Fig. 2



Fig. 3

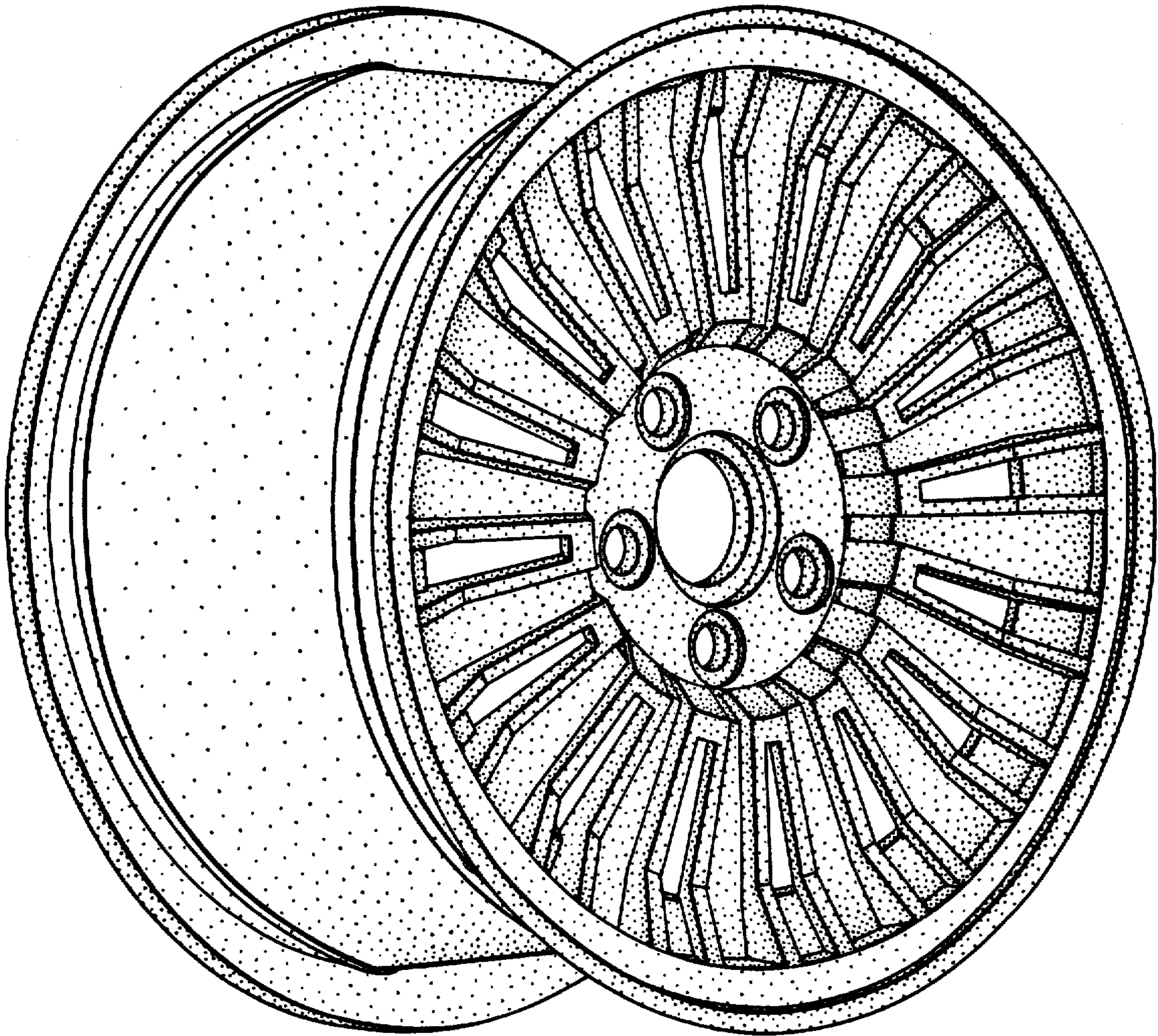

Fig. 4