

[54] **COMBINED HEADLIGHT AND SPEEDOMETER AND BRACKET THEREFORE**

[76] Inventor: **Orley R. Courtney**, 502 E. Wiley St., Marion, Ind. 46952

[**] Term: **14 Years**

[21] Appl. No.: **900,932**

[22] Filed: **Apr. 28, 1978**

[51] Int. Cl. **D26-06**

[52] U.S. Cl. **D26/34**

[58] Field of Search **D48/32 R, 24 A; 362/61, 362/62, 72, 235, 236, 237, 238, 240, 244, 245, 246, 257, 262, 282, 311, 362, 367, 368, 372, 374**

[56] **References Cited**

U.S. PATENT DOCUMENTS

D. 213,252 1/1969 Soubitez **D48/24 A**
2,168,939 8/1939 Kraeft **362/72 X**

FOREIGN PATENT DOCUMENTS

731722 6/1955 United Kingdom 362/72

Primary Examiner—Susan J. Lucas
Attorney, Agent, or Firm—Lundy and Associates

[57] **CLAIM**

The ornamental design for a combined headlight and speedometer and bracket therefore, as shown and described.

DESCRIPTION

FIG. 1 is a top plan view of the combined headlight and speedometer and bracket therefore showing my new design;

FIG. 2 is a side view thereof;

FIG. 3 is a side view thereof showing the side opposite that shown in FIG. 2;

FIG. 4 is a front view thereof;

FIG. 5 is a rear view thereof;

FIG. 6 is a bottom view thereof; and

FIG. 7 is a fragmentary bottom perspective view thereof on an enlarged scale, the bracket being fragmentarily shown for convenience of illustration.

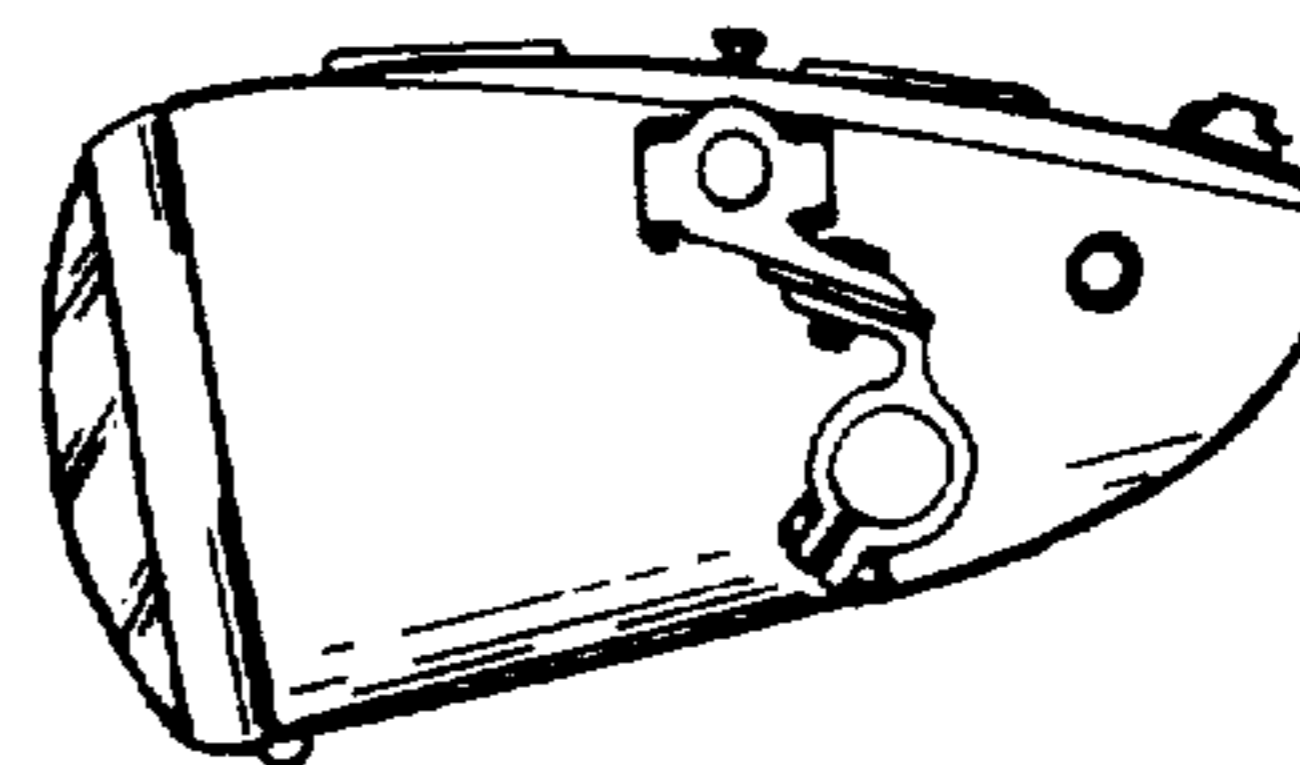
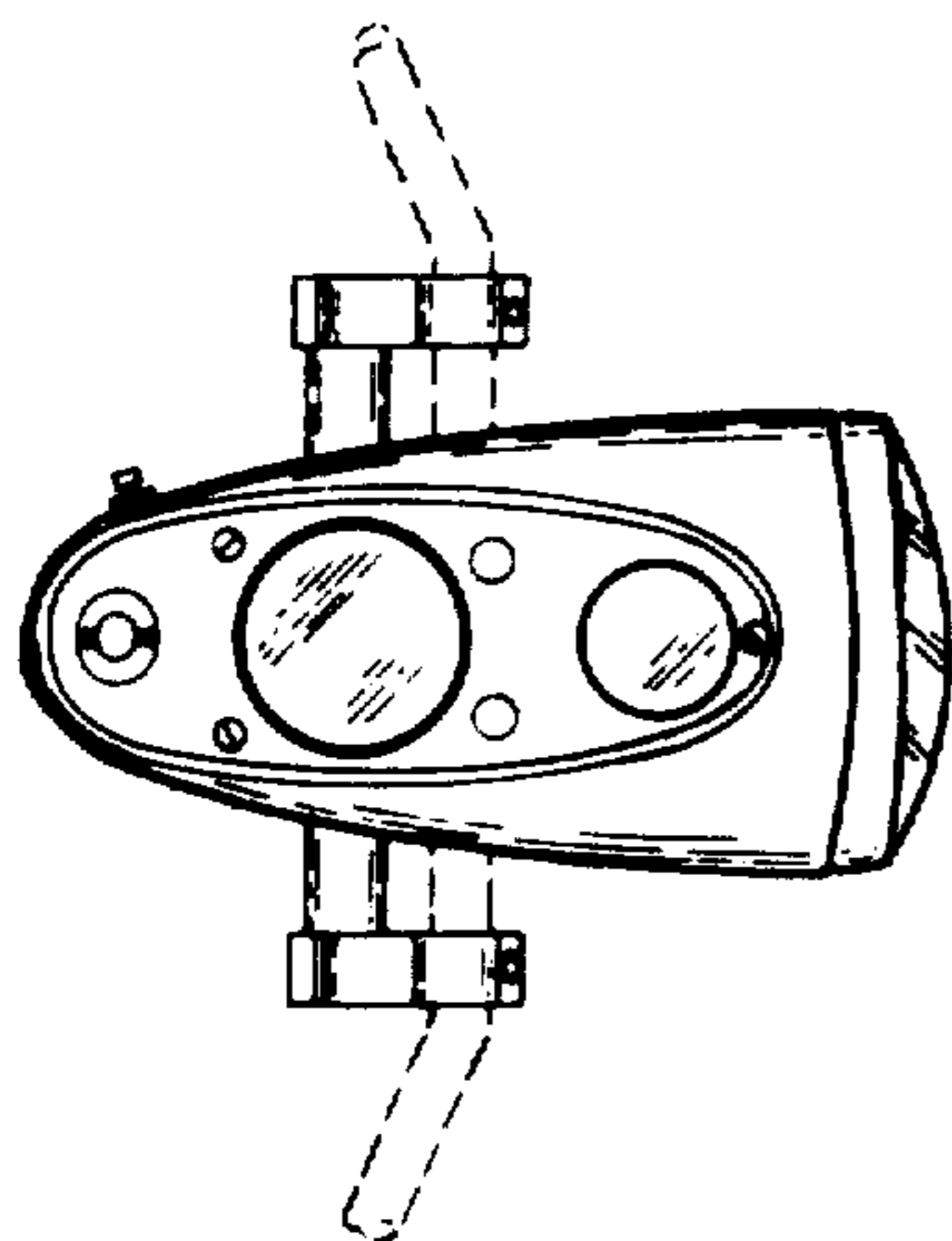

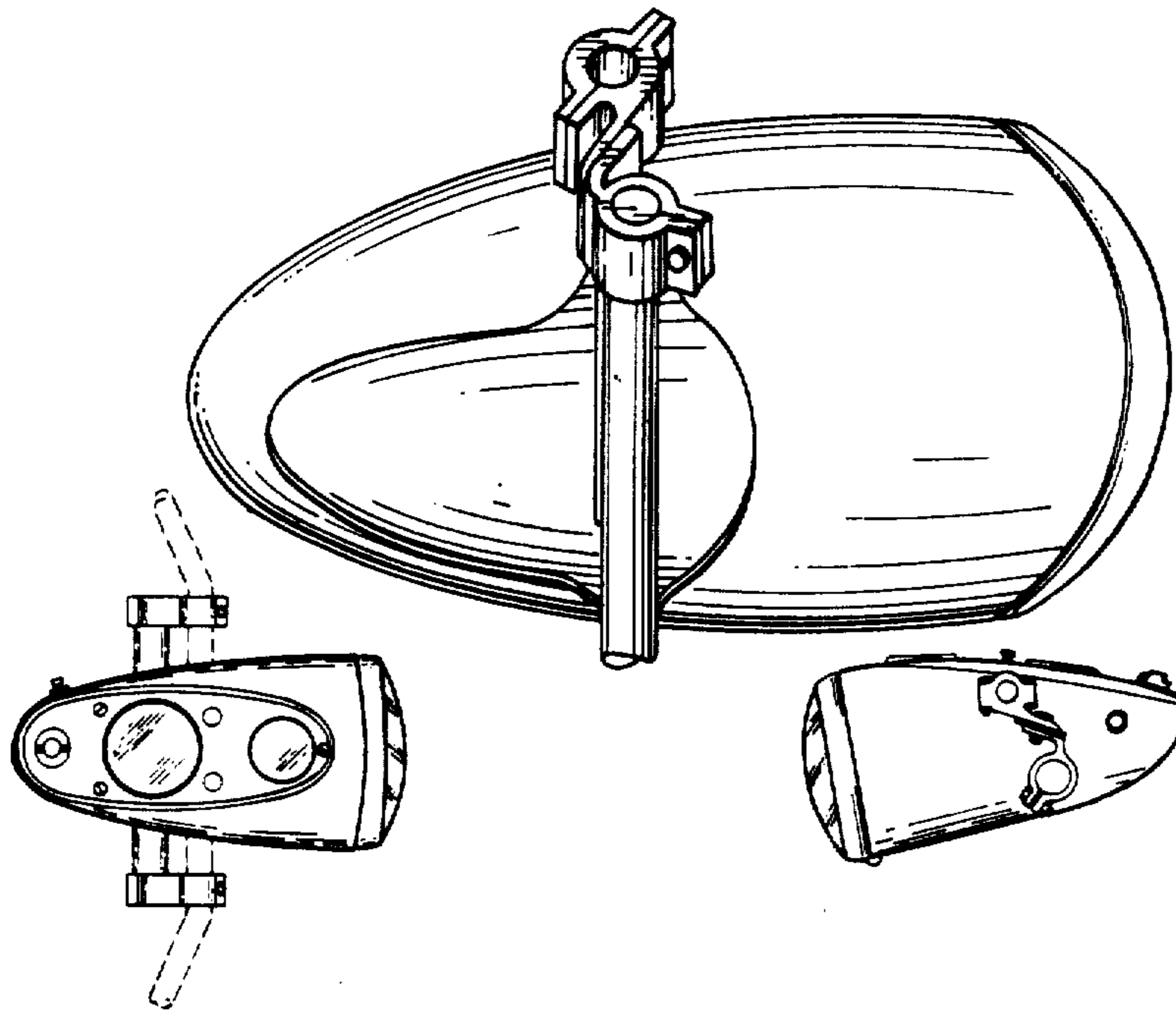

FIG. 1

FIG. 2

FIG. 7

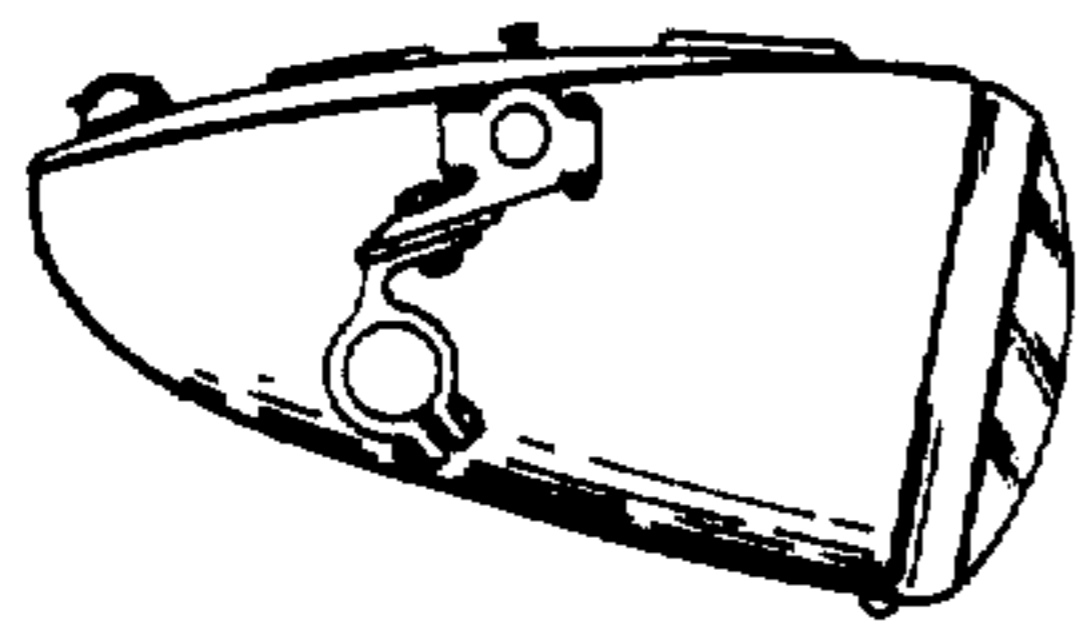

FIG. 3

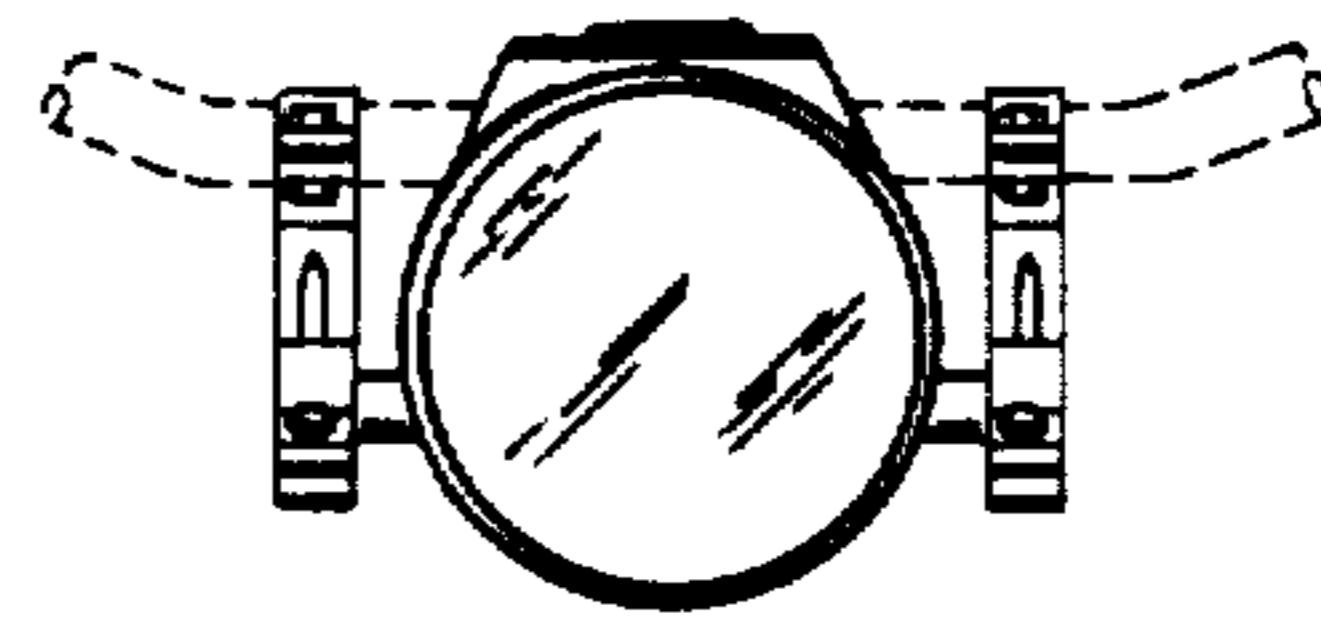

FIG. 4

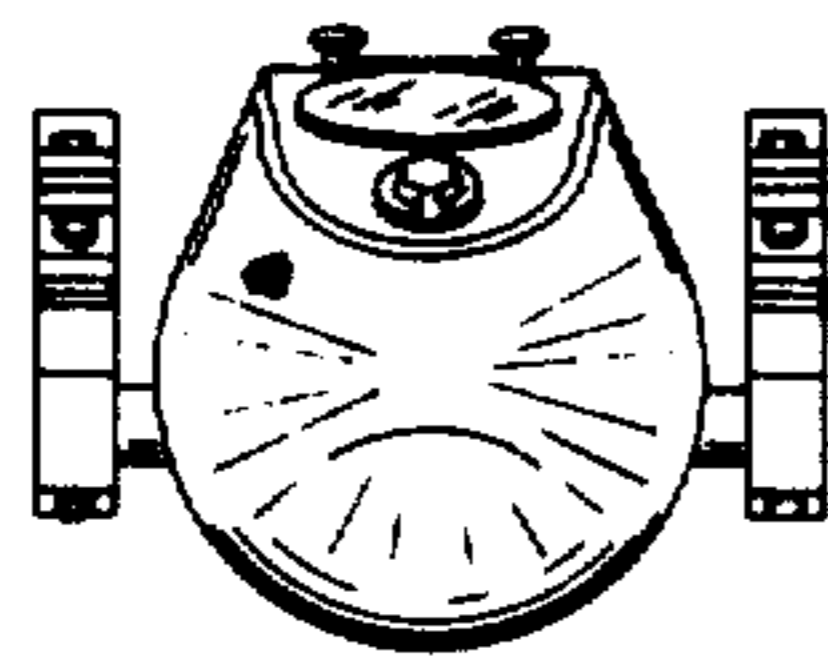

FIG. 5

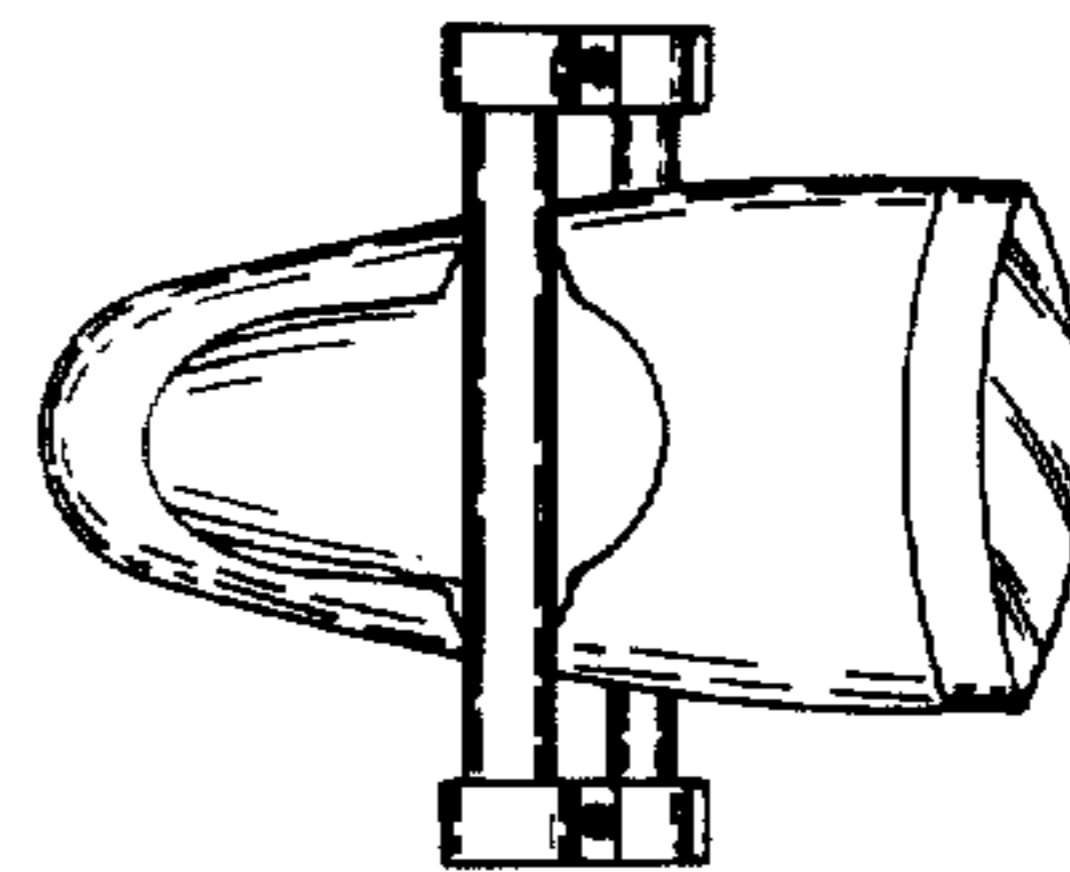

FIG. 6