

[54] COMBINED SEAT AND EASEL  
[76] Inventor: Peter K. Arnold, New Artist School of Fine Art, 8 Durham St. East, Auckland, New Zealand

[\*\*] Term: 14 Years

[21] Appl. No.: 971,761

[22] Filed: Dec. 21, 1978

[51] Int. Cl. .... D6-05

[52] U.S. Cl. .... D6/17; D6/64; D6/180

[58] Field of Search ..... D6/17, 180; 297/195, 297/201, 204; 248/454

[56] References Cited

U.S. PATENT DOCUMENTS

D. 140,281	2/1945	Weller et al. ....	D6/17
D. 145,659	10/1946	Covington ....	D6/17
D. 182,061	2/1958	Cote ....	D6/17

D. 183,407	8/1958	Schaefer .....	D6/17
D. 207,959	6/1967	Gervais .....	D6/17
D. 209,048	10/1967	Schafer et al. ....	D6/17
D. 252,237	7/1979	Demaio .....	D6/17

Primary Examiner—Bruce W. Dunkins  
Attorney, Agent, or Firm—Ladas & Parry

[57] CLAIM

The ornamental design for a combined seat and easel, as shown and described.

DESCRIPTION

FIG. 1: is a perspective view of a combined seat and easel showing my new design.

FIG. 2: is a side elevation view.

FIG. 3: is a top plan view.

FIG. 4: is an underside plan view.

FIG. 5: is a front elevation view.

FIG. 6: is a rear elevation view.

FIG. 7: is a side elevation view of the combined seat and easel when collapsed for transport.

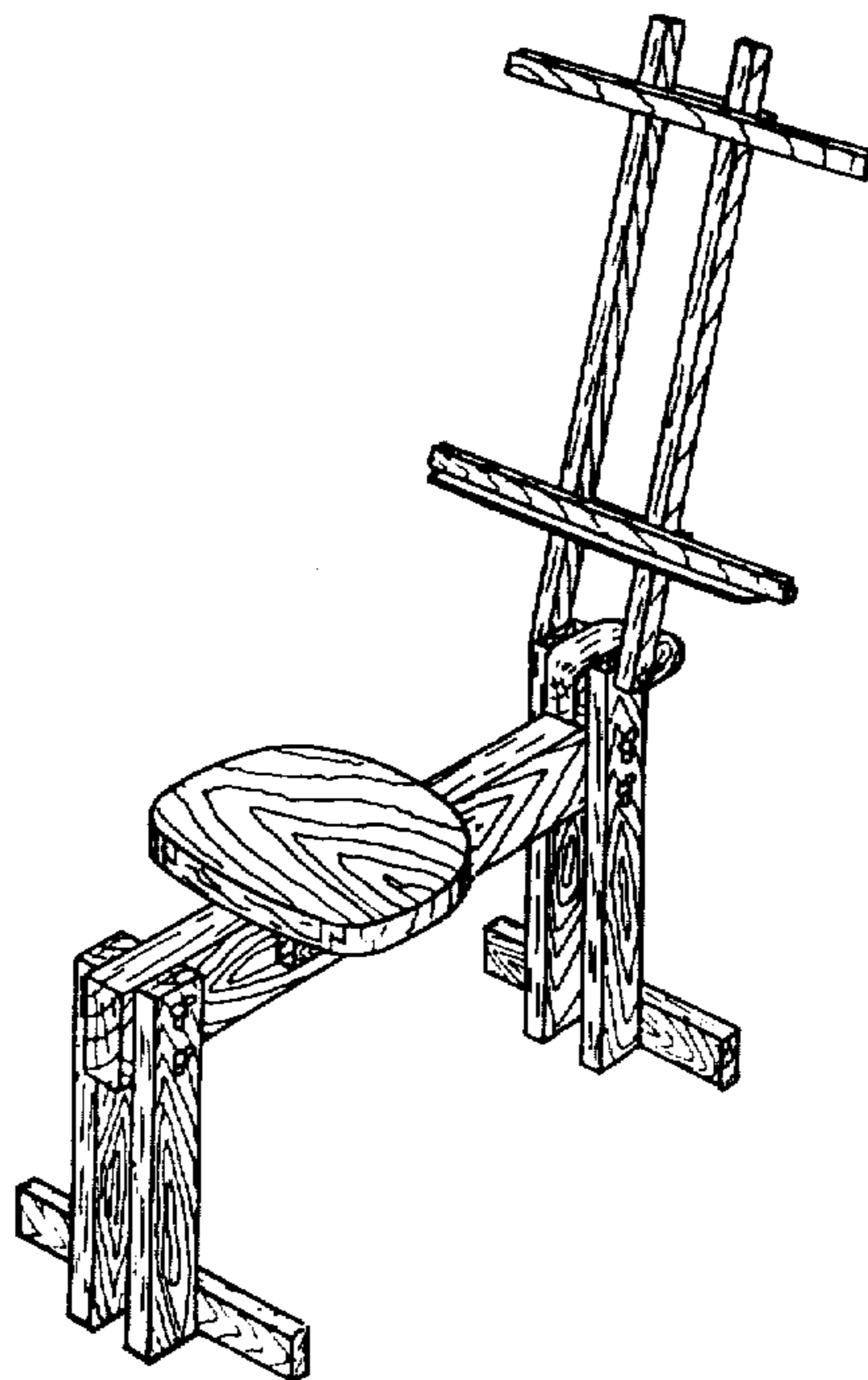

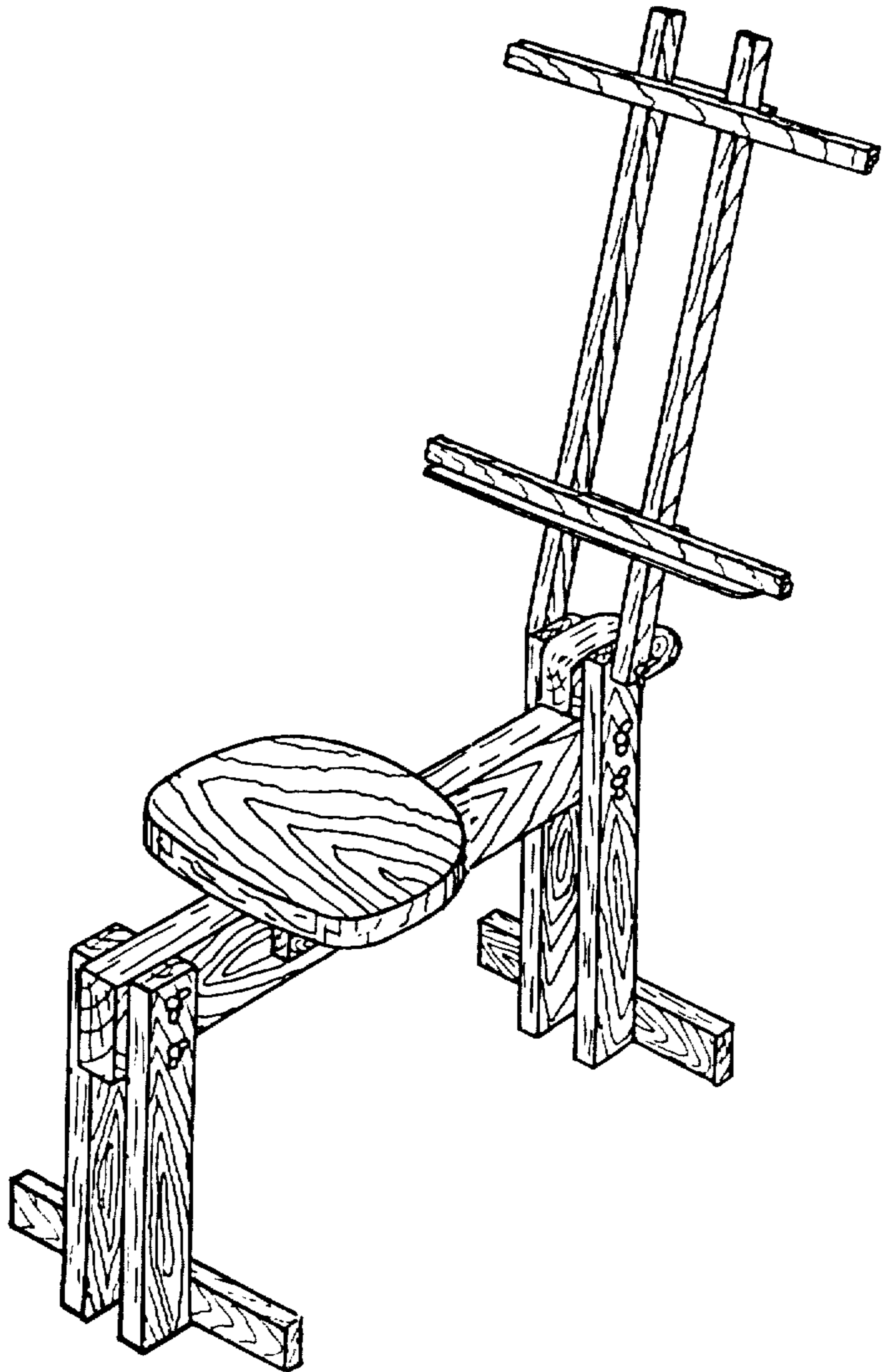

FIGURE 1

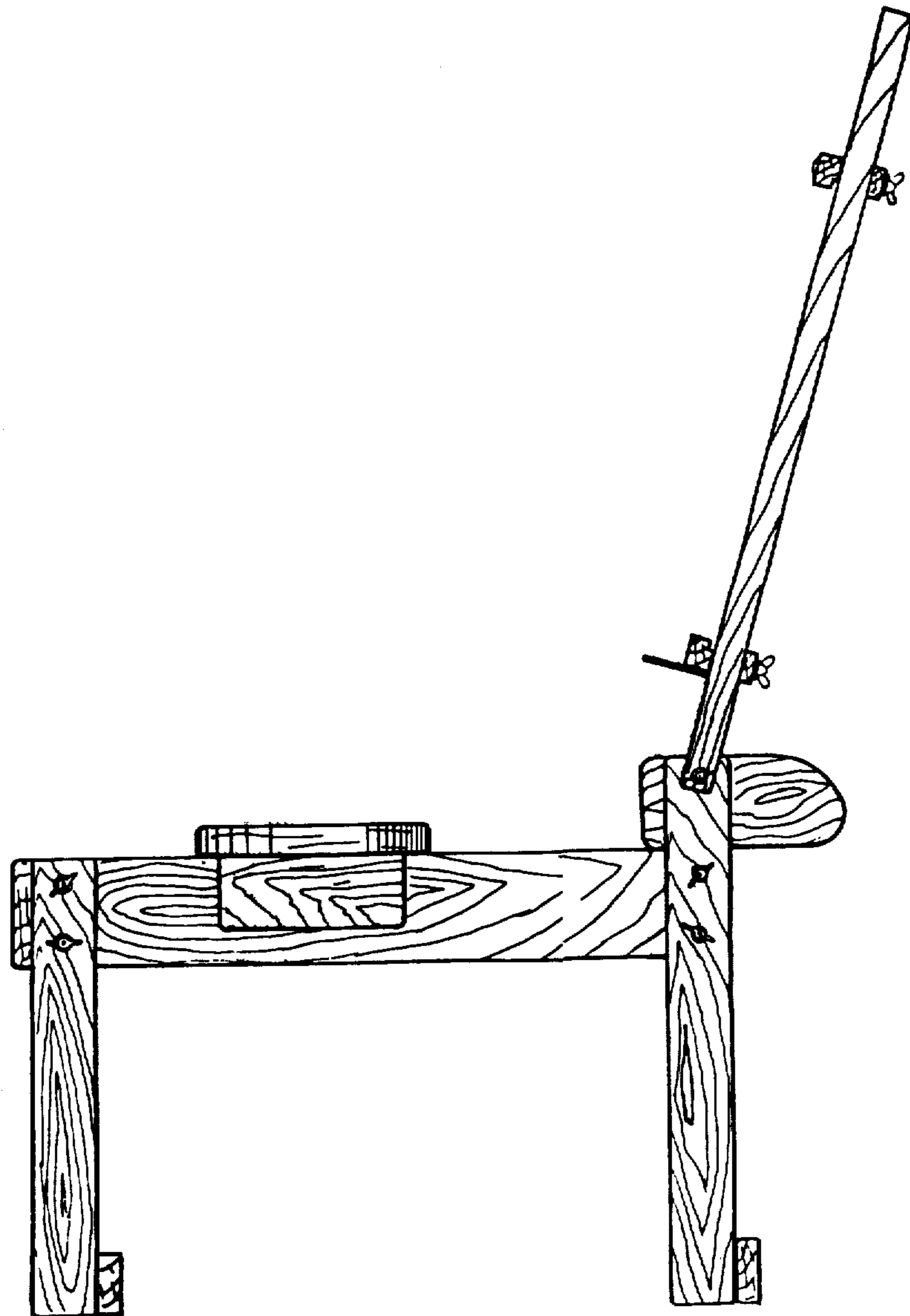

FIGURE 2

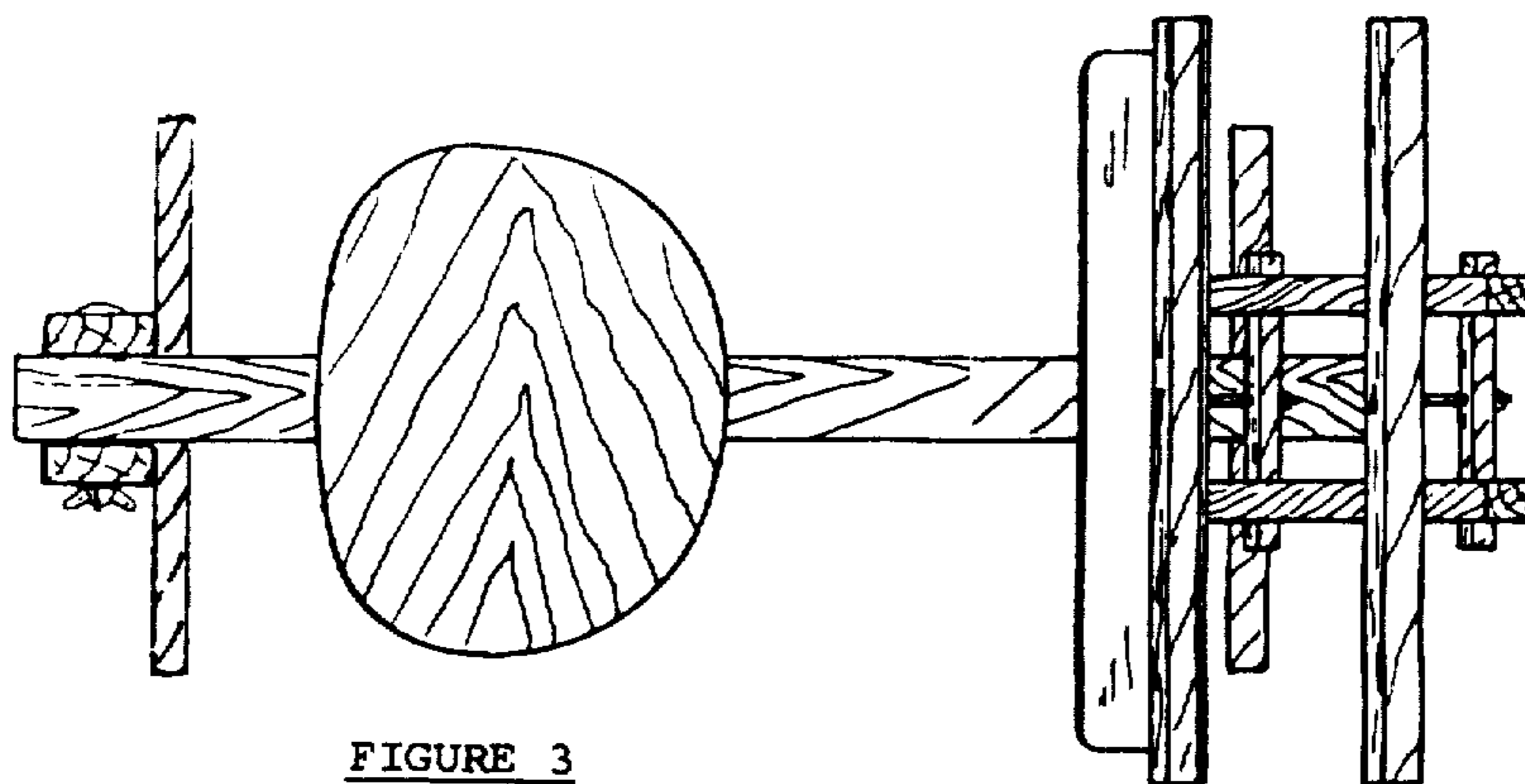

FIGURE 3

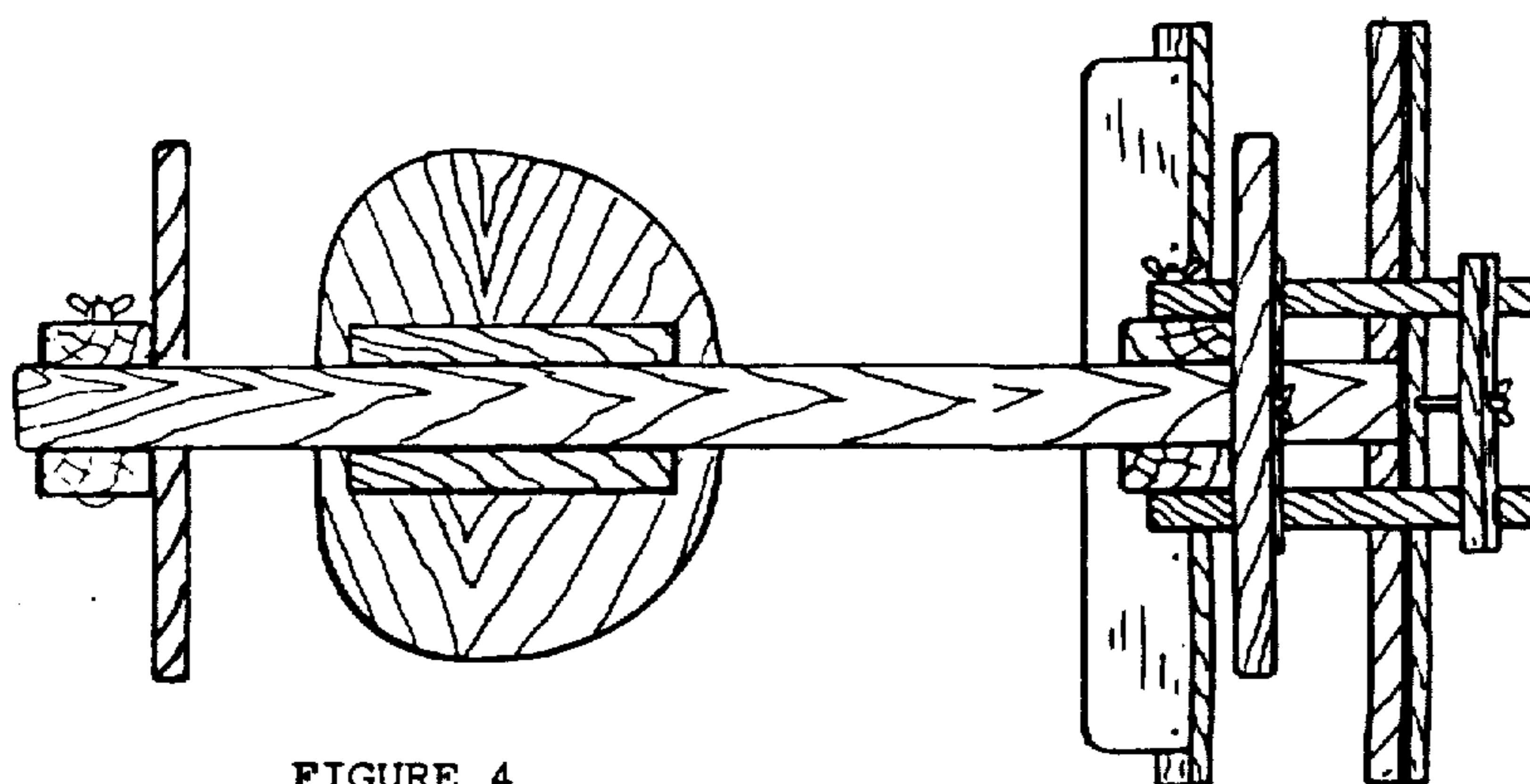

FIGURE 4

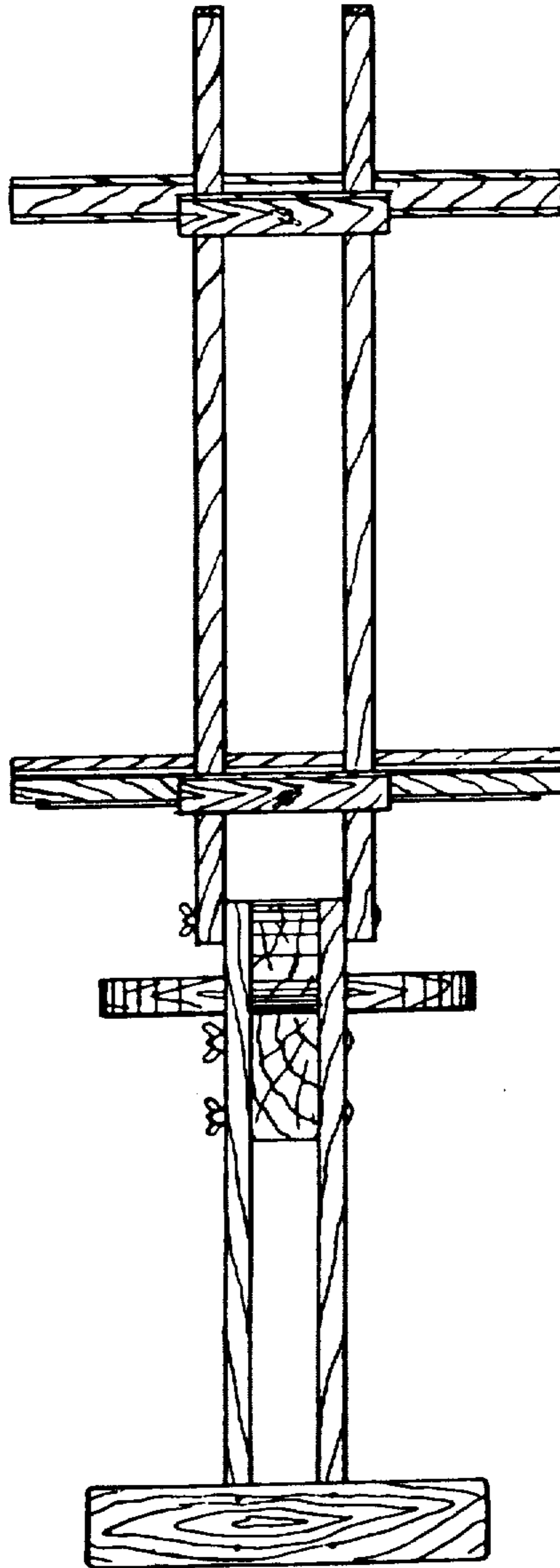

FIG. 5

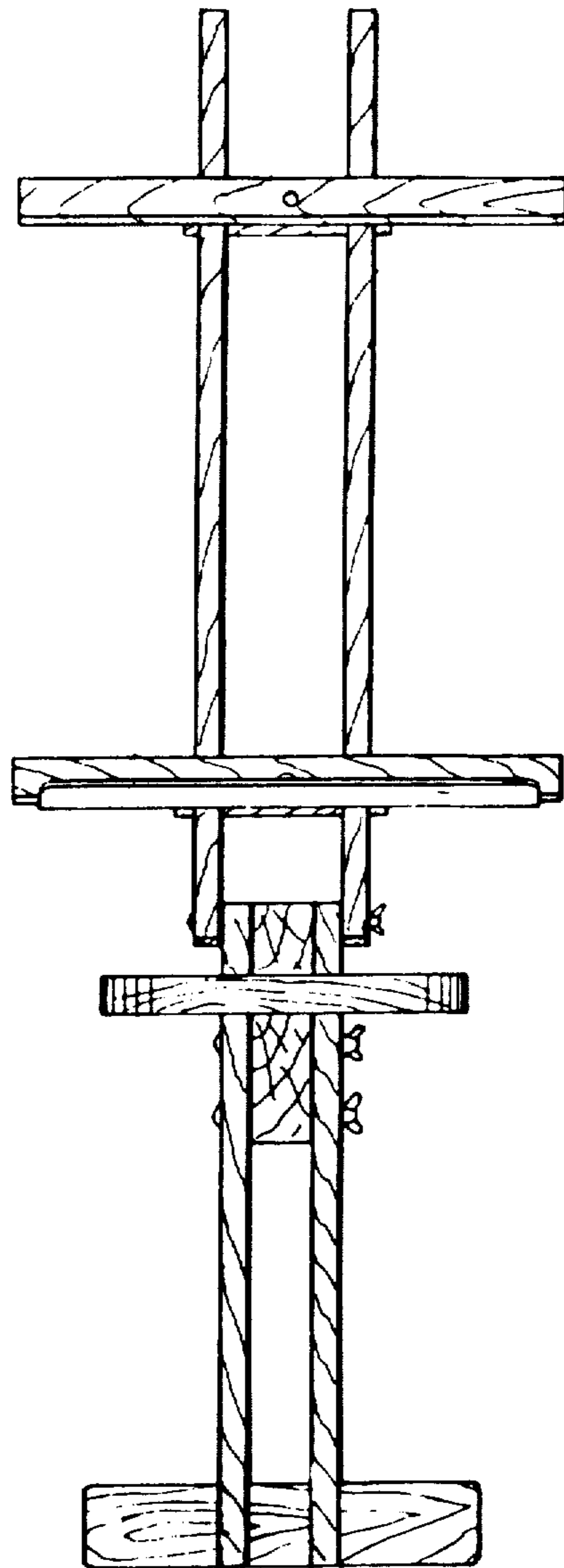

FIG. 6

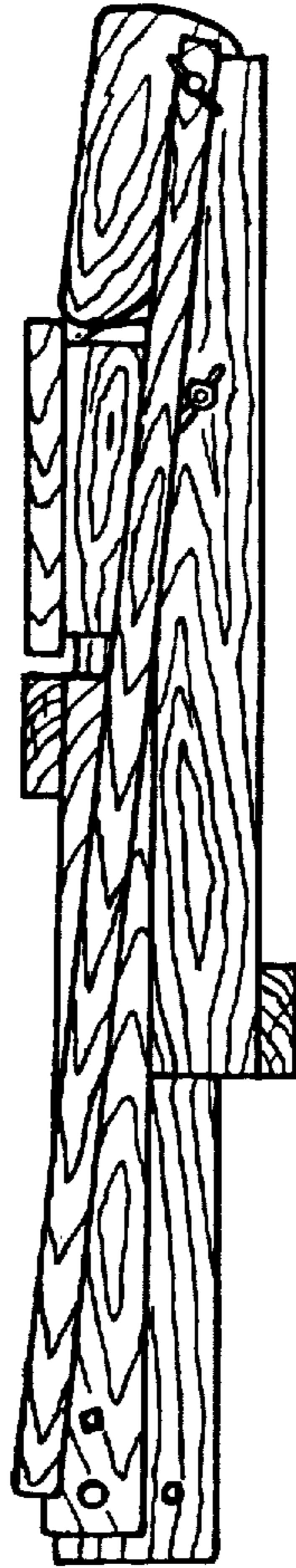

FIGURE 7