

[54] TOY CRANE TRUCK

[75] Inventor: Jack L. Breneman, Orchard Park, N.Y.

[73] Assignee: The Quaker Oats Company, Chicago, Ill.

[**] Term: 14 Years

[21] Appl. No.: 952,697

[22] Filed: Oct. 19, 1978

[51] Int. Cl. D21-01

[52] U.S. Cl. D21/131

[58] Field of Search D21/128, 131, 132, 133, D21/134, 135, 141; D12/1, 14, 15, 57, 82; 46/214, 215, 222, 201, 202, 209, 252, 251; D15/10, 12

[56] References Cited

U.S. PATENT DOCUMENTS

D. 210,229 2/1968 Genin D21/133
D. 244,476 5/1977 Asano D21/132

D. 246,479 11/1977 Asano D21/132
D. 252,231 6/1979 Asano D21/131

OTHER PUBLICATIONS

Sears 1977, "Wish Book", p. 565, item #7, Michigan Shovel.

Wards Xmas Catalog, 1977, p. 356, item #10, "Hook-N-Ladder".

Primary Examiner—Charles A. Rademaker
Attorney, Agent, or Firm—Cumpston & Shaw

[57] CLAIM

The ornamental design for a toy crane truck, substantially as shown.

DESCRIPTION

FIG. 1 is a right-side elevational view of a toy crane truck showing my new design;
FIG. 2 is a top plan view thereof;
FIG. 3 is a left-side elevational view thereof;
FIG. 4 is a bottom plan view thereof;
FIG. 5 is a front elevational view thereof;
FIG. 6 is a rear elevational view.

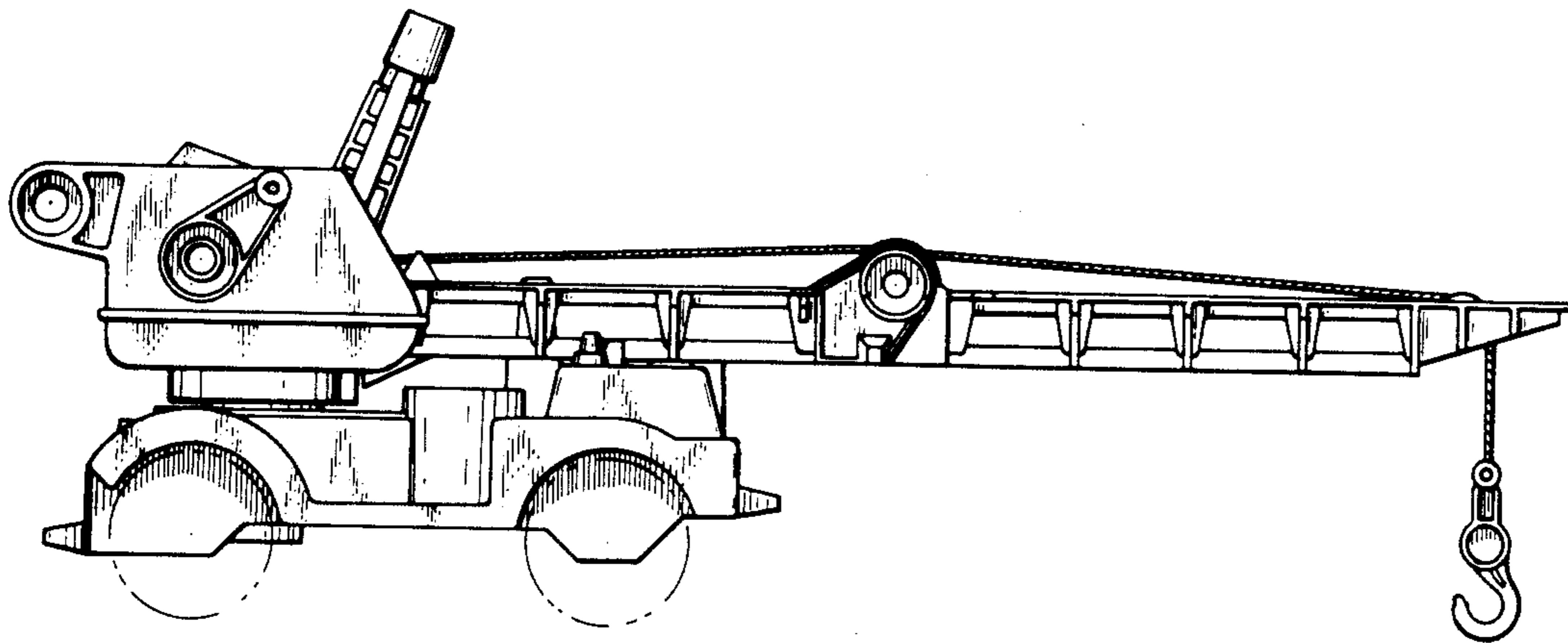

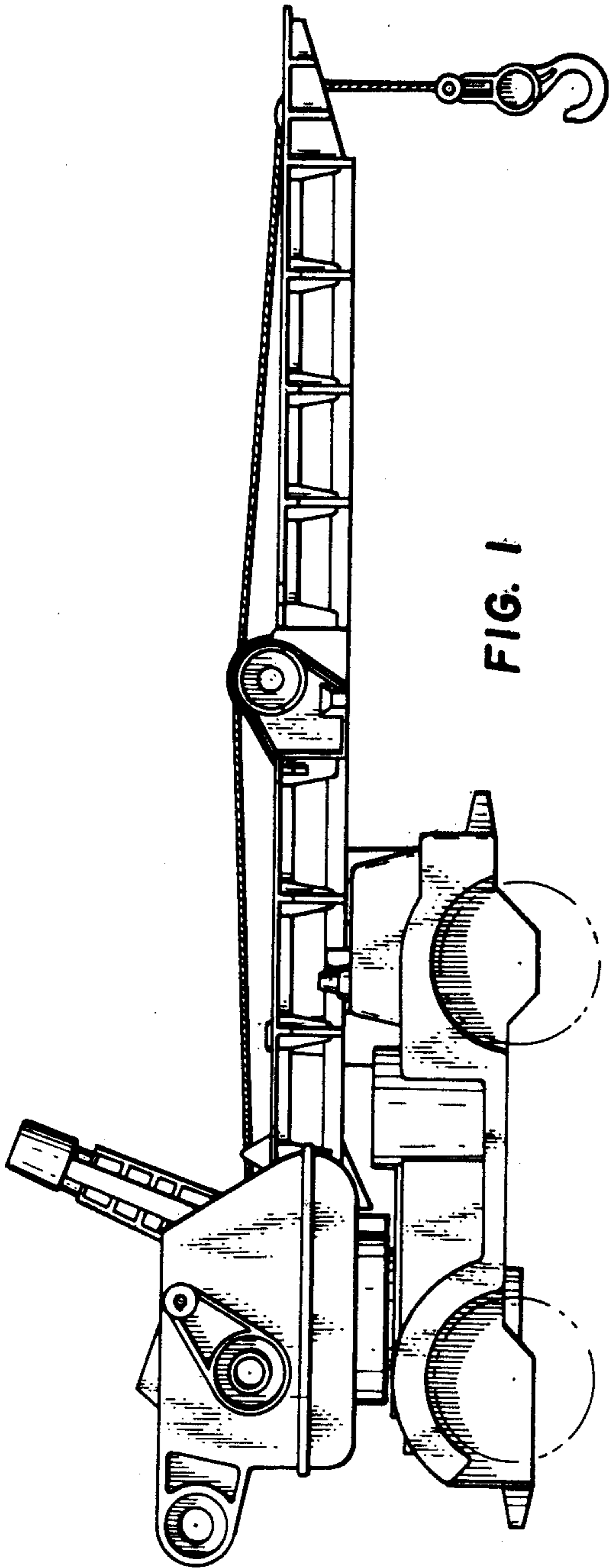

FIG. 1

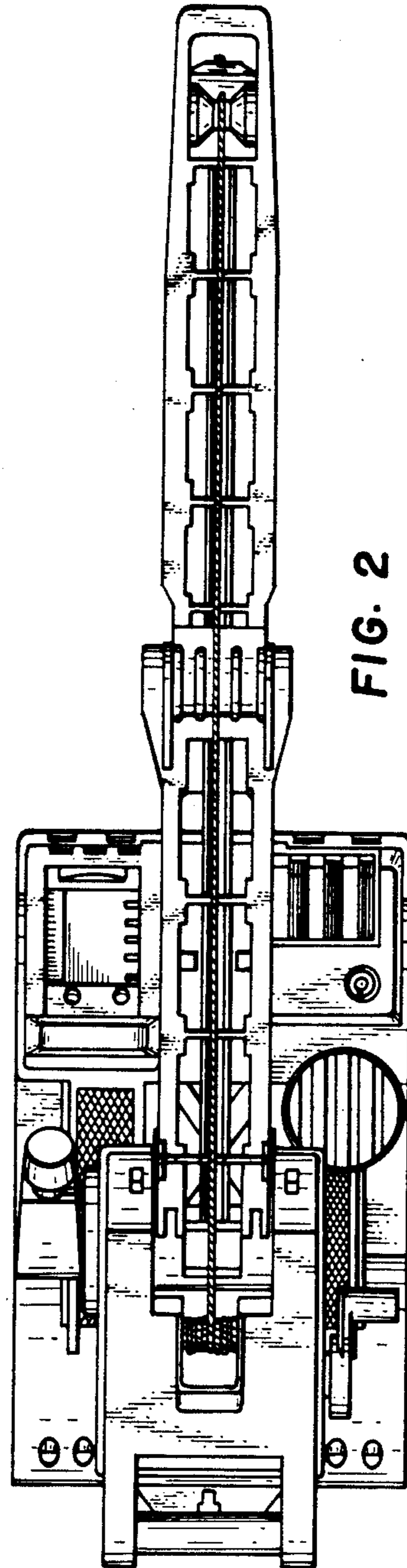
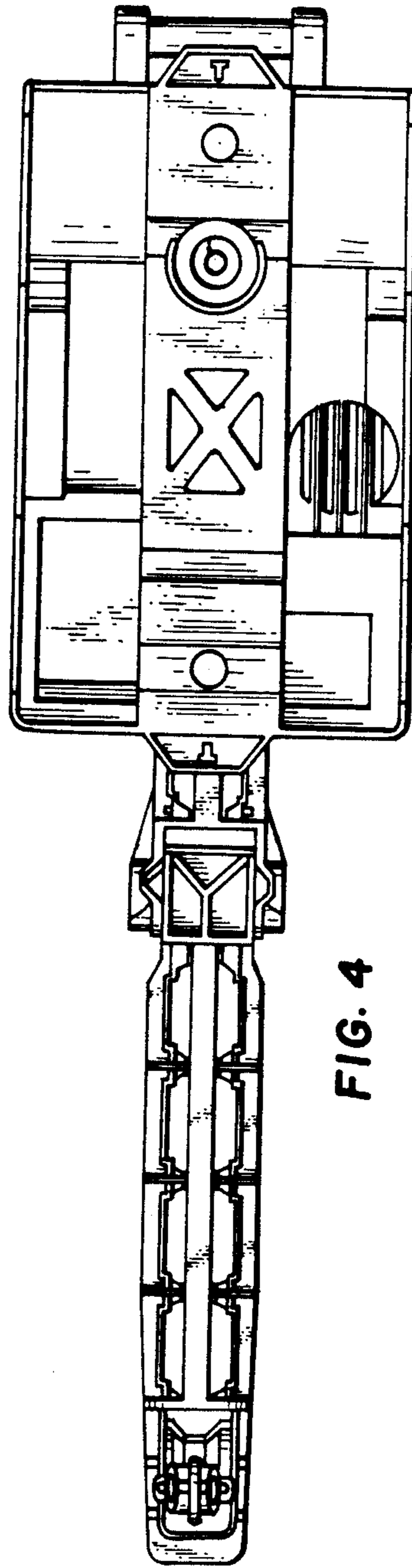
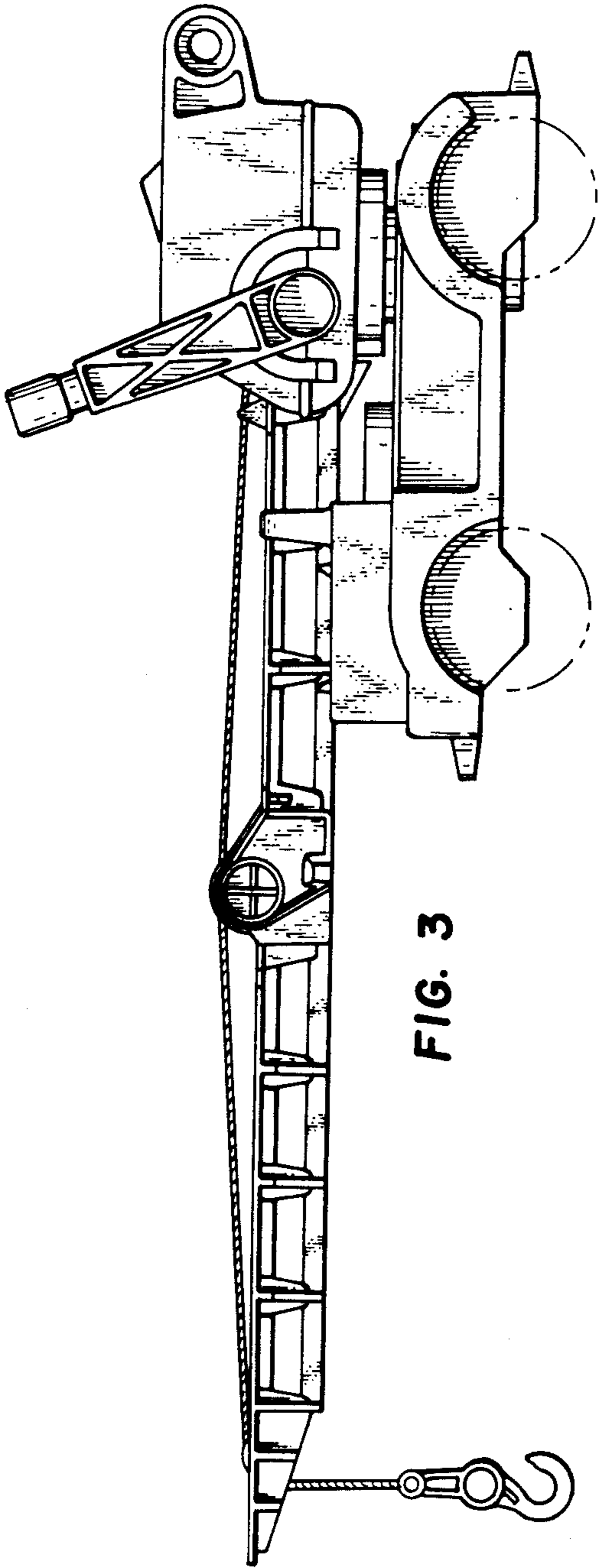

FIG. 2



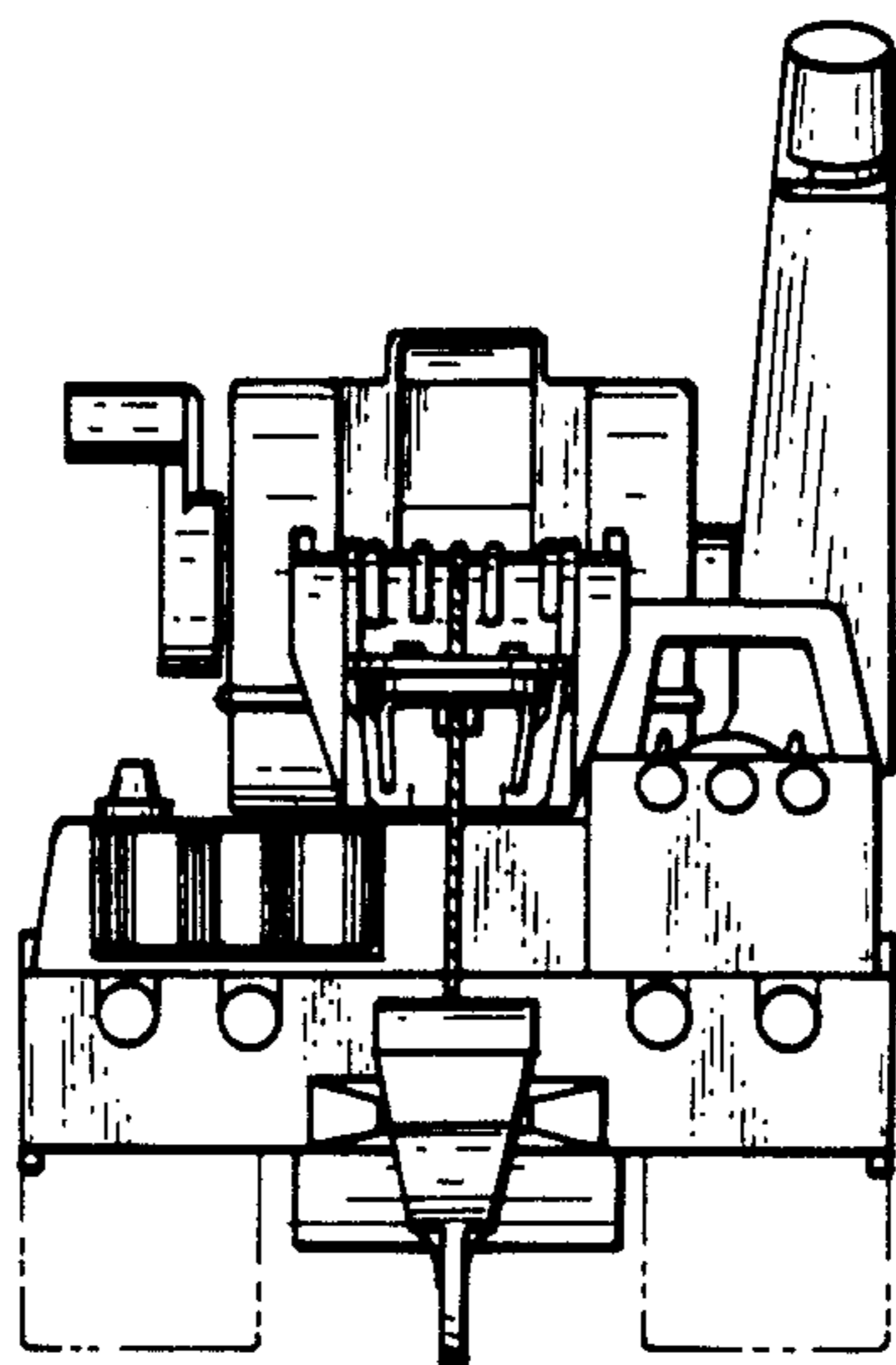

FIG. 5

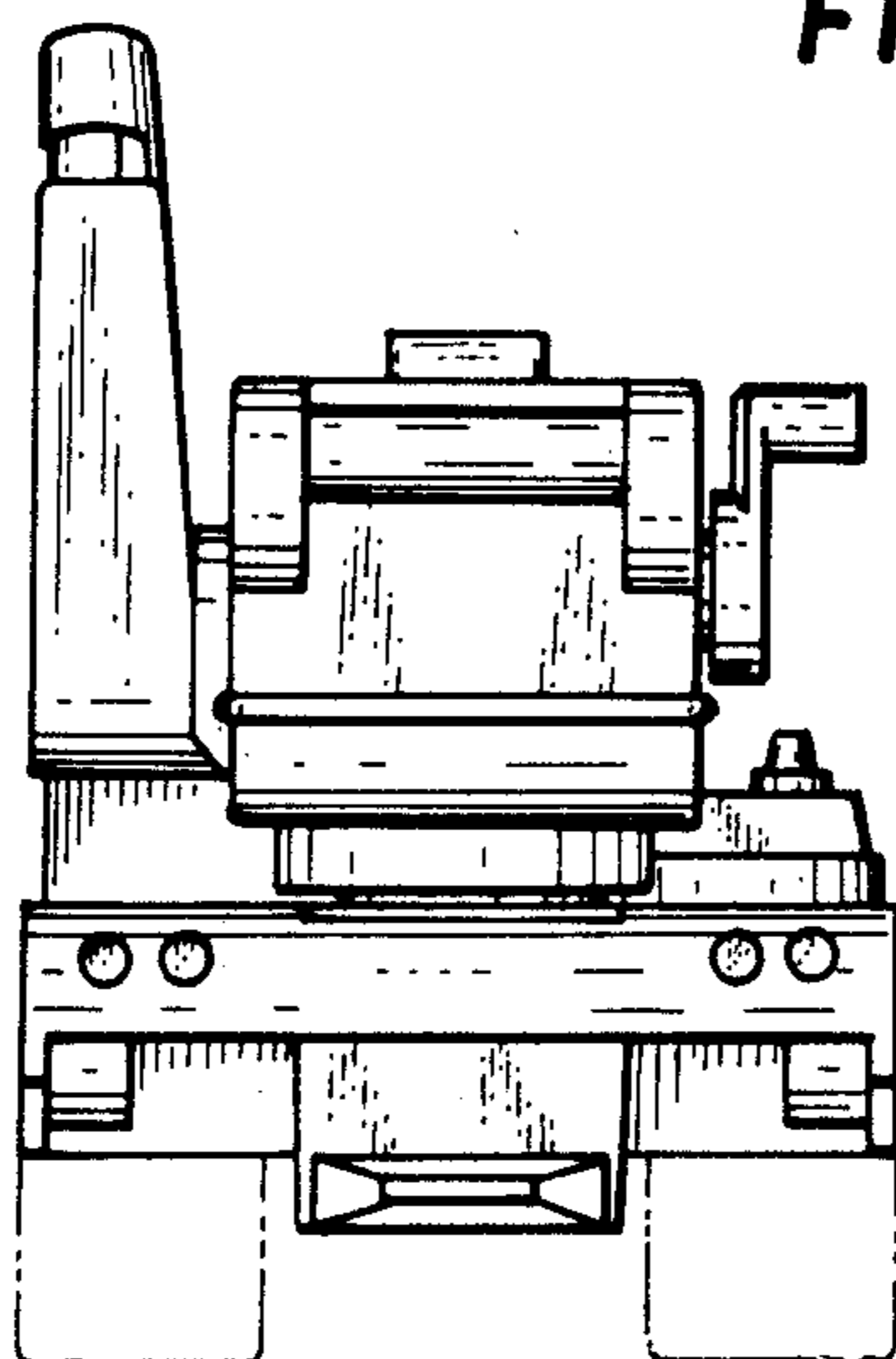

FIG. 6