

[54] CASTER

2,049,344 7/1936 Wittke, Jr. 16/18 R
2,468,399 4/1949 Grossman 16/18 R

[76] Inventor: Kiyooki Kameda, 2635 Omiya,
Fujinomiya-shi, Japan

Primary Examiner—Bruce W. Dunkins
Attorney, Agent, or Firm—Schwartz & Weinrieb

[**] Term: 14 Years

[21] Appl. No.: 950,668

[57] CLAIM

The ornamental design for "a caster", substantially as shown.

[22] Filed: Oct. 12, 1978

[51] Int. Cl. D6—99

[52] U.S. Cl. D6/191

[58] Field of Search D6/191, 194, 195, 196;
16/18 R, 18 A, 18 CG, 18 B, 19

DESCRIPTION

FIG. 1 is an elevational view of a caster according to the present invention;

FIG. 2 is a rear elevational view of FIG. 1;

FIG. 3 is a top view of FIG. 1;

FIG. 4 is a left side view of FIG. 1;

FIG. 5 is a right side view of FIG. 1;

FIG. 6 is a bottom view of FIG. 1; and

FIG. 7 is a longitudinal sectional view, taken along the line VII—VII in FIG. 1.

[56] References Cited

U.S. PATENT DOCUMENTS

199,313 1/1878 Ritchey 16/18 R
1,066,754 7/1913 Risom 16/18 B
1,285,142 11/1918 Happensack 16/18 CG

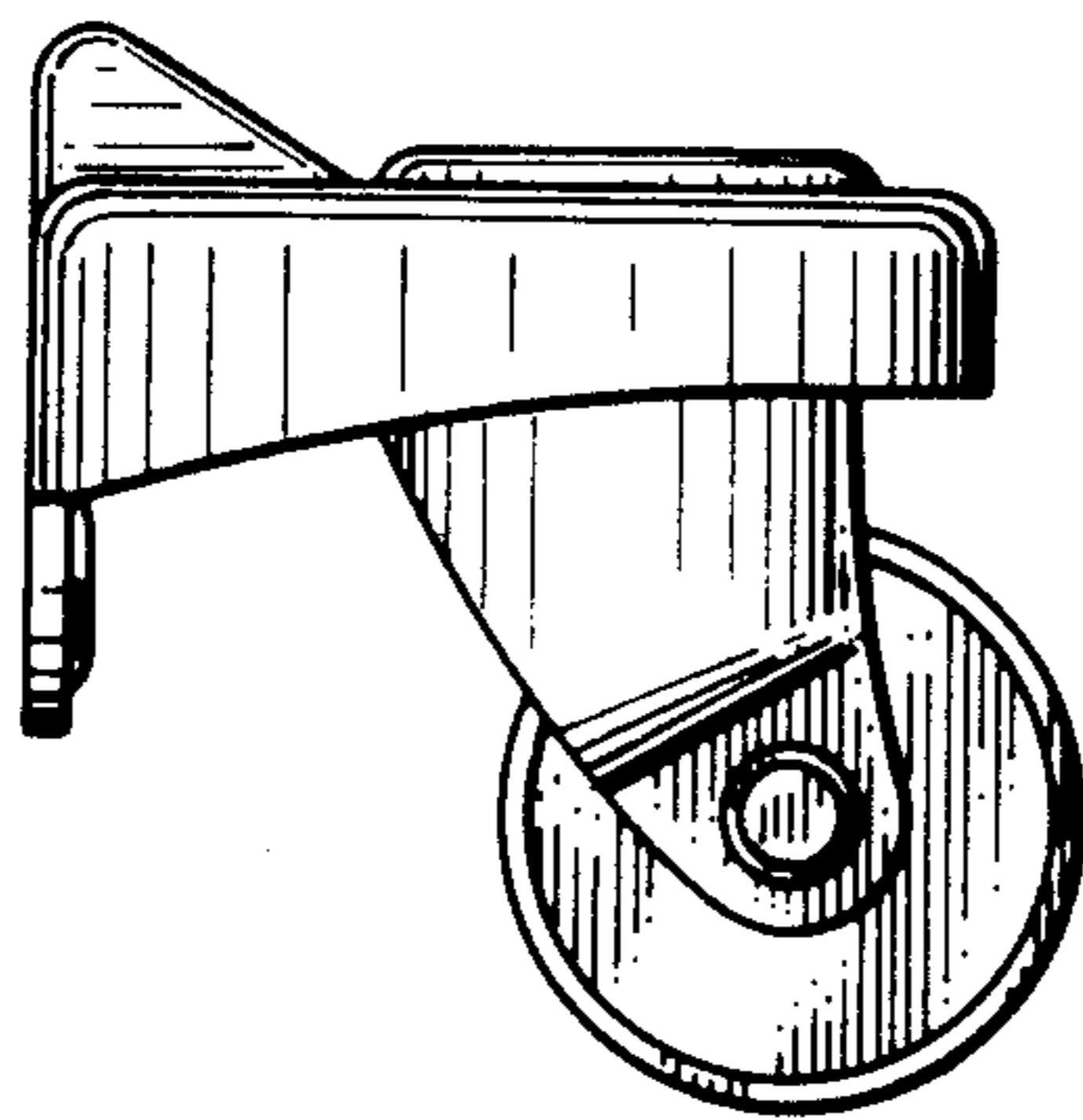

FIG. 1

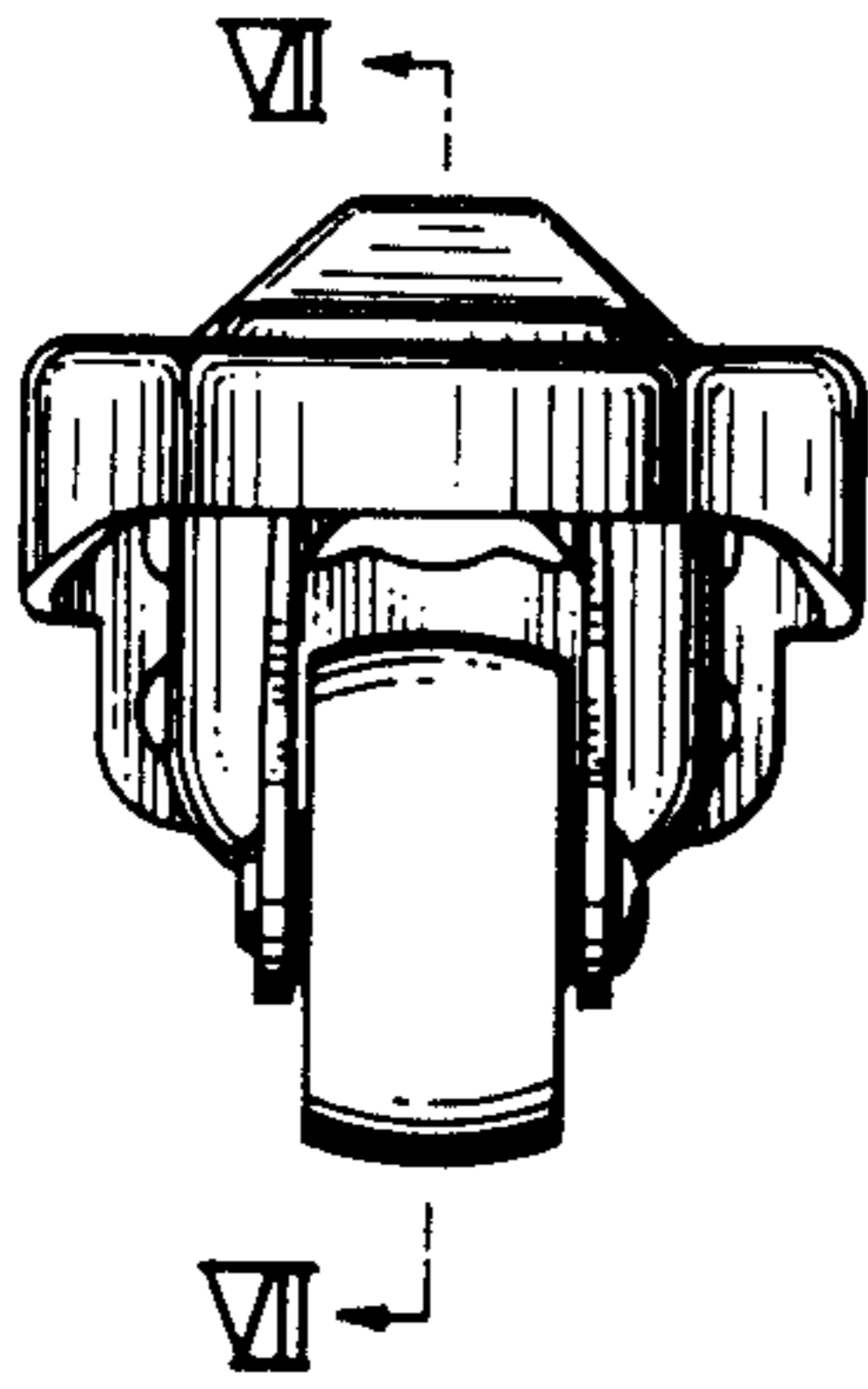

FIG. 2

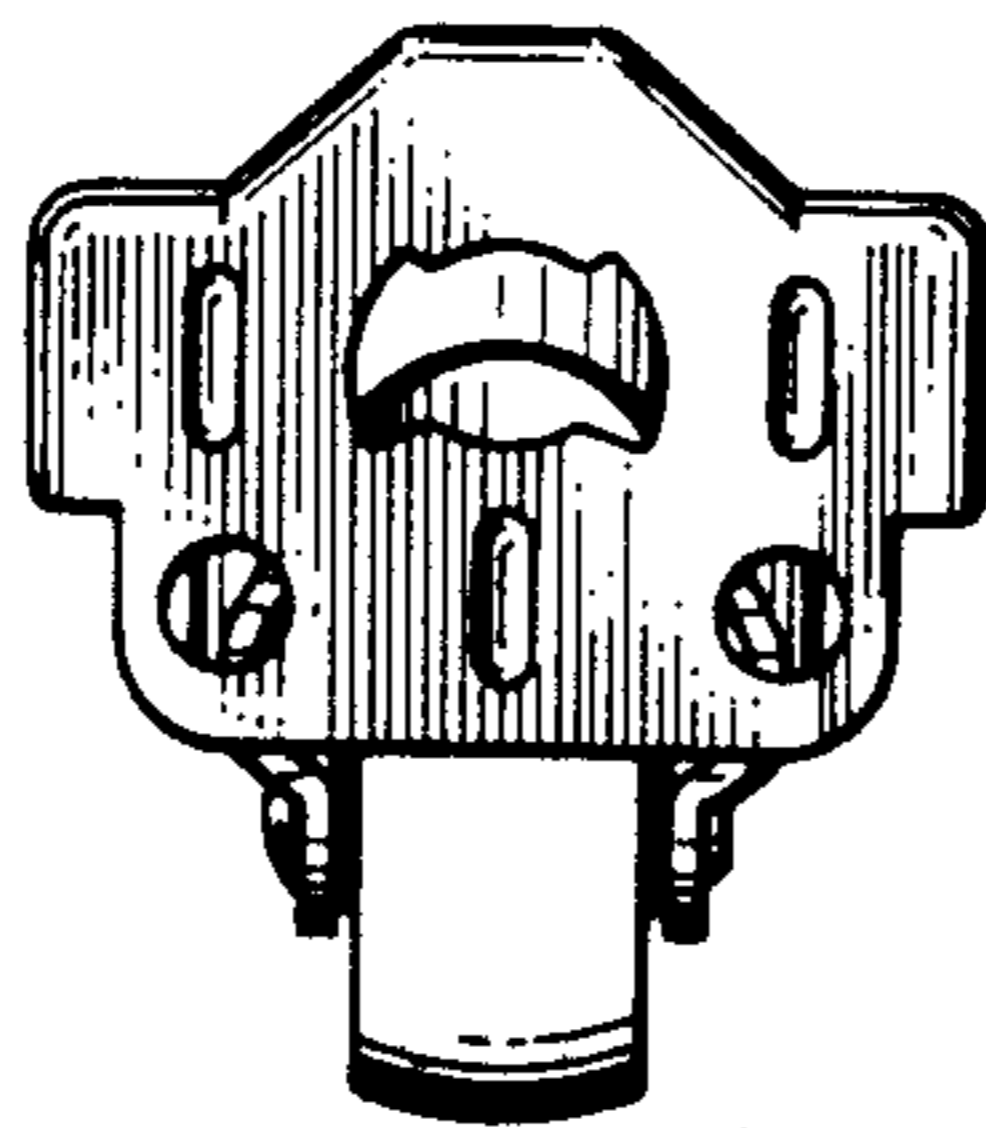

FIG. 3

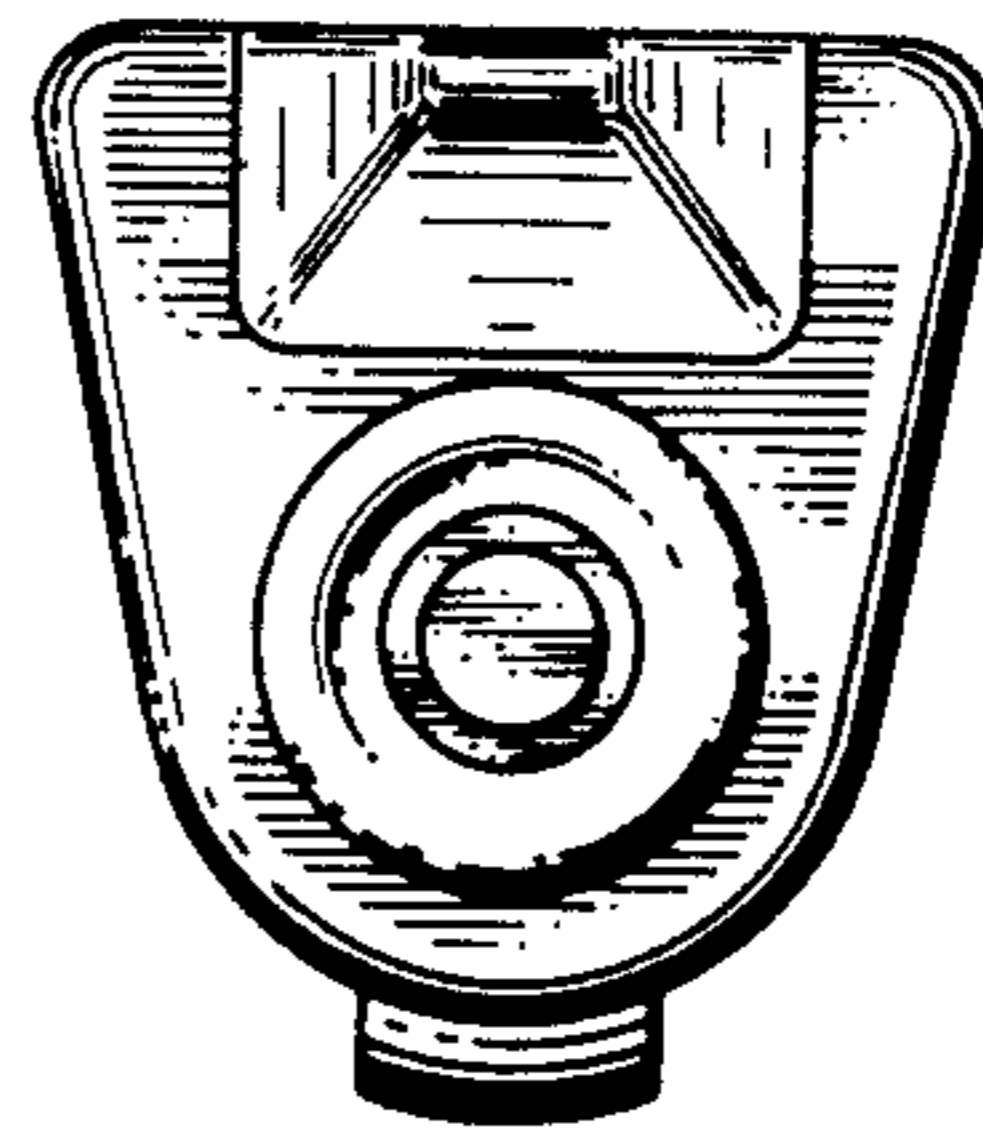

FIG. 4

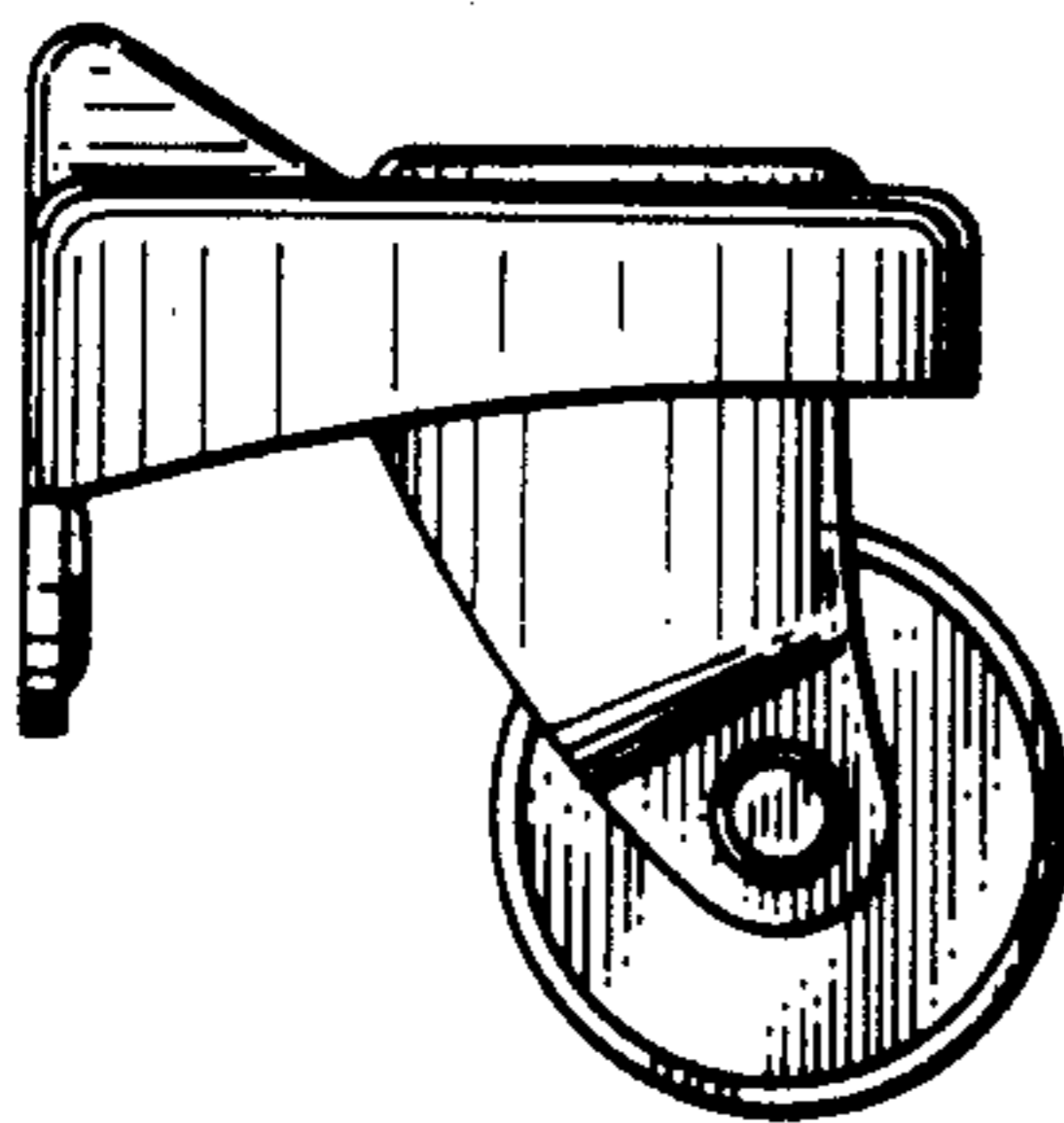

FIG. 5

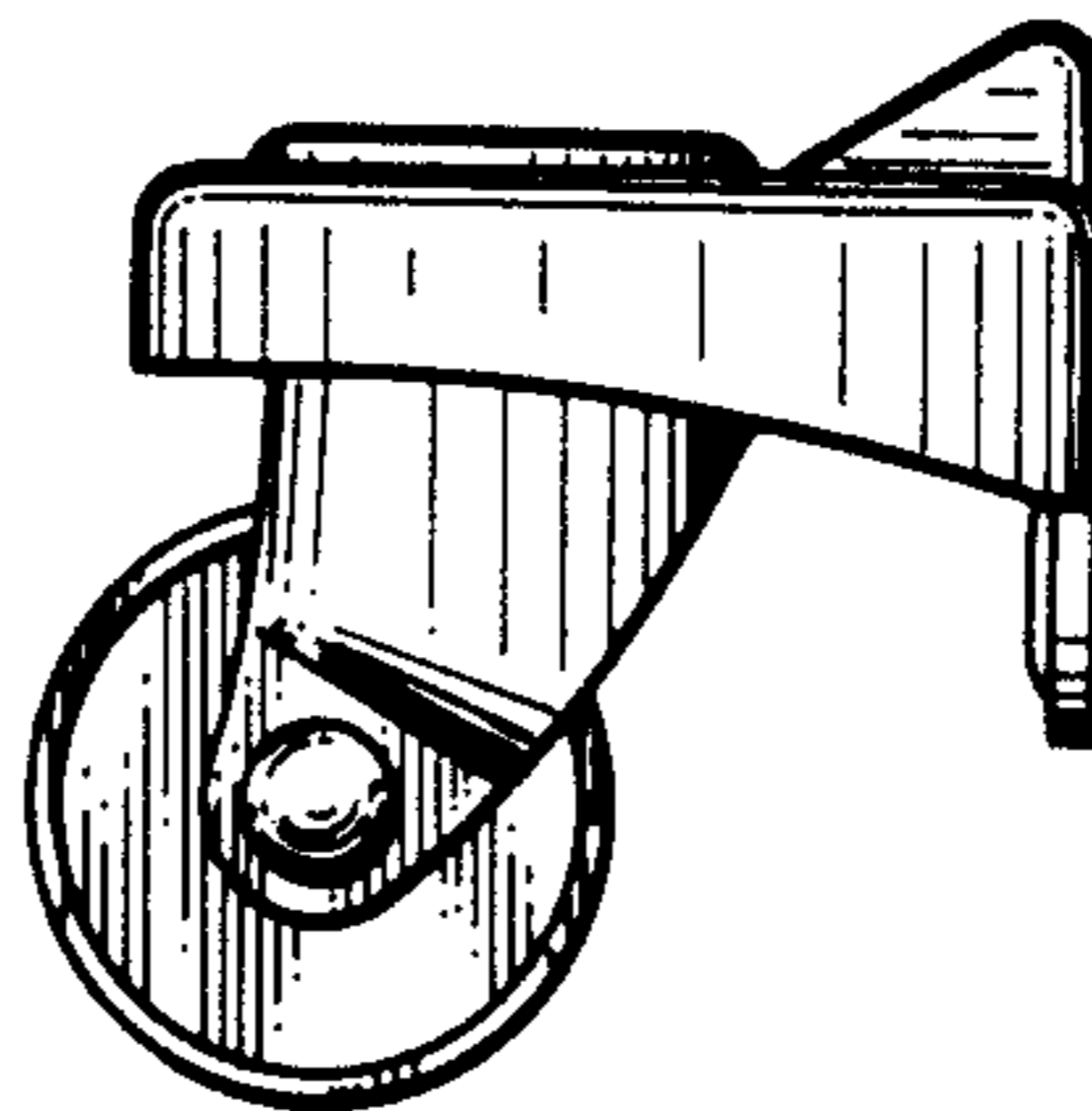

FIG. 6

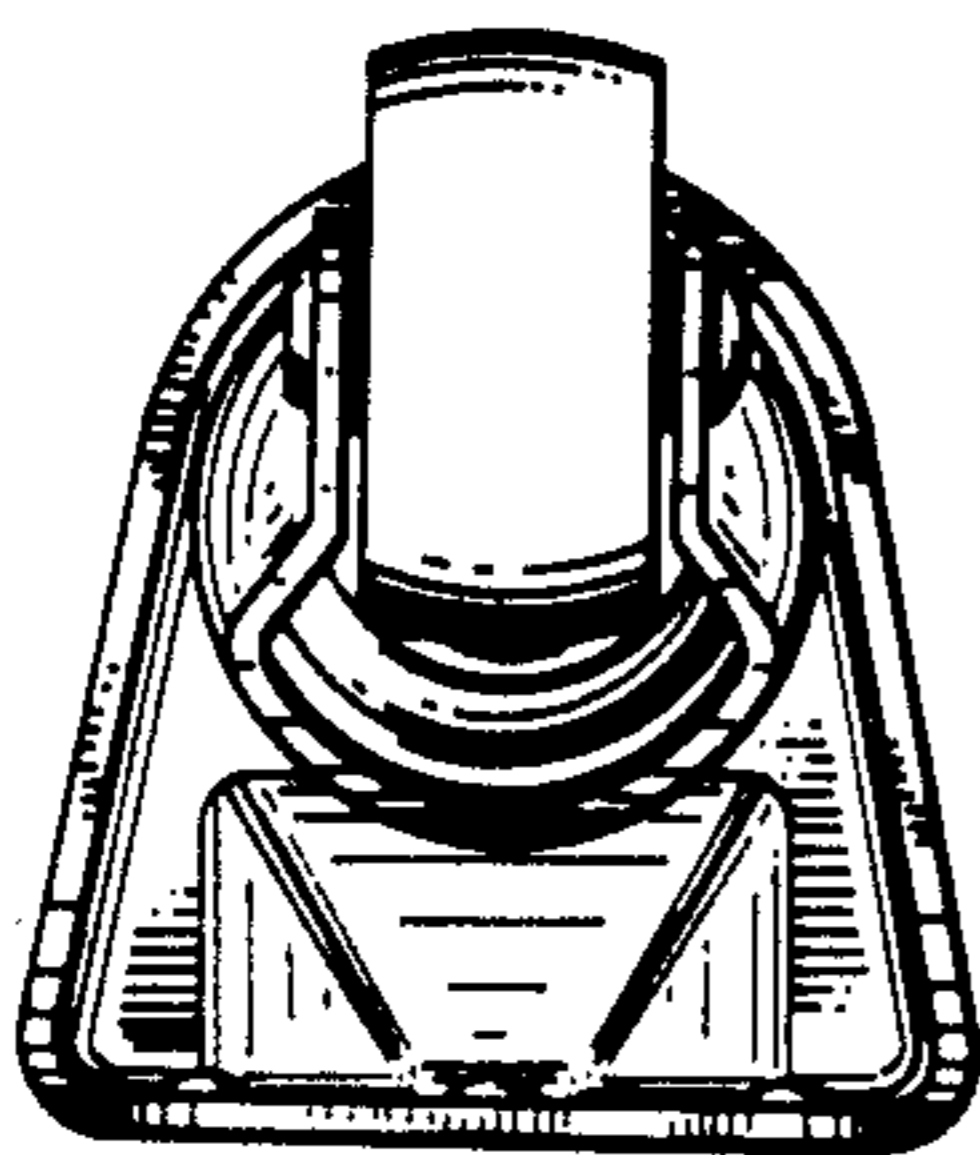

FIG. 7

