

[54] TENDER COMPRISING FOUR SEPARATE HULL PARTS

[76] Inventor: Stefan Norlund, Ståltrådsvägen 32, 161 31 Bromma, Sweden

[\*\*] Term: 14 Years

[21] Appl. No.: 890,759

[22] Filed: Mar. 27, 1978

[30] Foreign Application Priority Data

Sep. 26, 1977 [SE] Sweden ..... 1929

[51] Int. Cl. .... D12-06

[52] U.S. Cl. .... D12/62

[58] Field of Search ..... D12/62; 9/2 S

[56] References Cited

U.S. PATENT DOCUMENTS

D. 226,870	5/1973	Livingston .....	D12/62
D. 232,816	9/1974	Miya et al. ....	D12/62
3,822,427	7/1974	Ewart, Jr. ....	9/2 S

Primary Examiner—Alan P. Douglas  
Attorney, Agent, or Firm—Sughrue, Rothwell, Mion, Zinn and Macpeak

[57] CLAIM

The ornamental design for a tender comprising four separate hull parts, as shown and described.

DESCRIPTION

FIG. 1 is a perspective view of the tender in a position of use.

FIG. 2 is an exploded view of the separate parts of the tender in a dismounted state.

FIG. 3 is a perspective view of the tender in a transporting position.

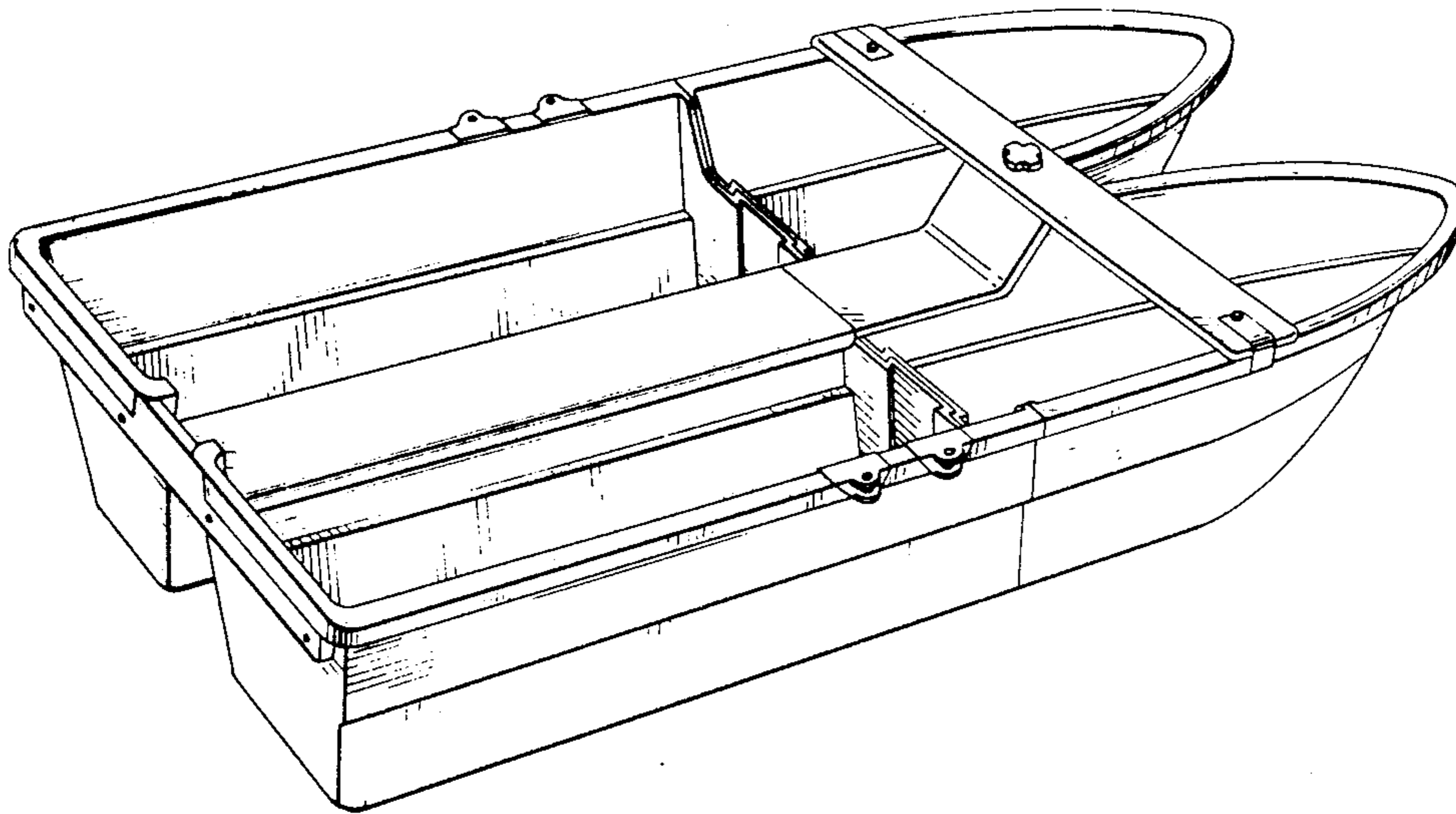

**FIG. 1**

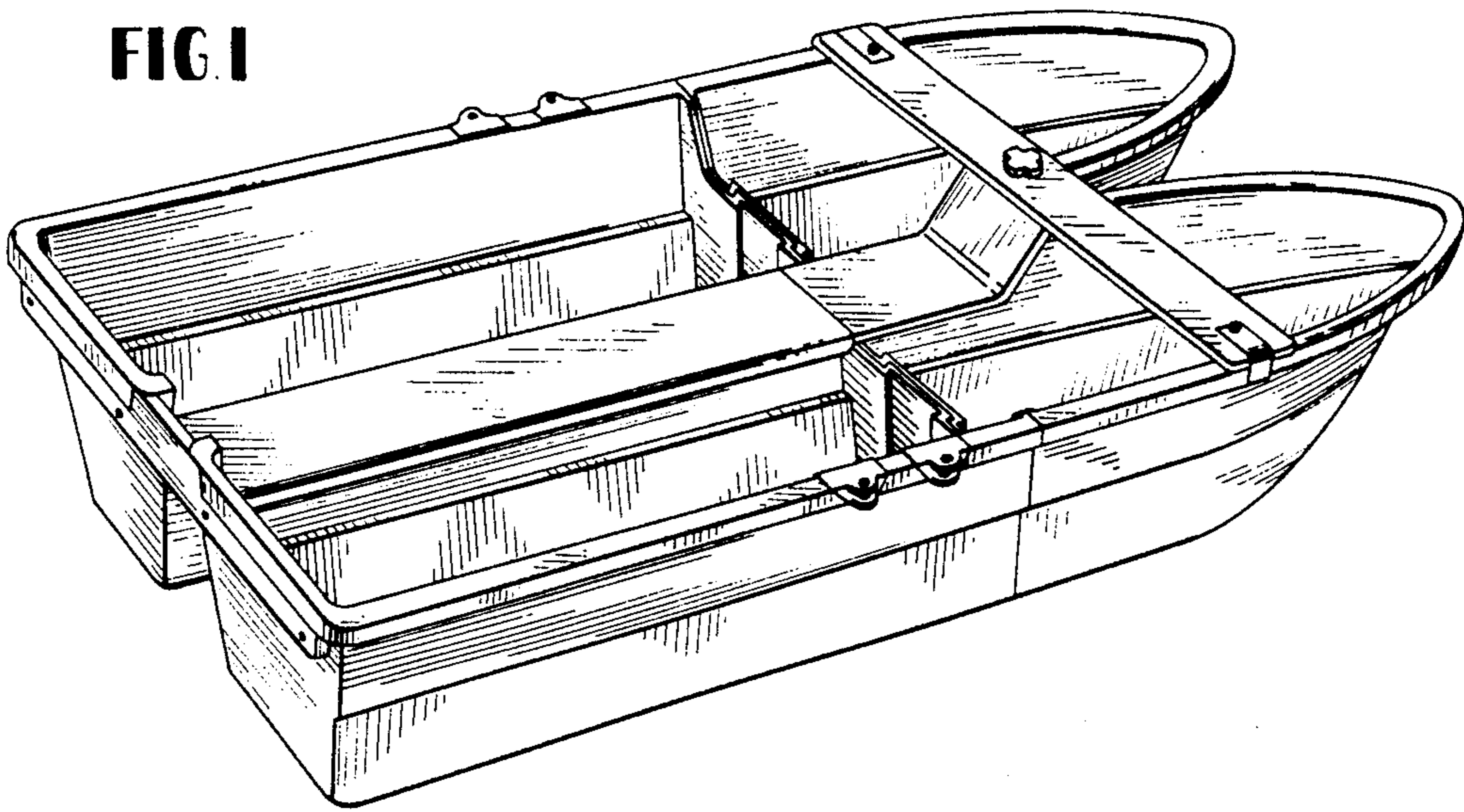

**FIG. 3**

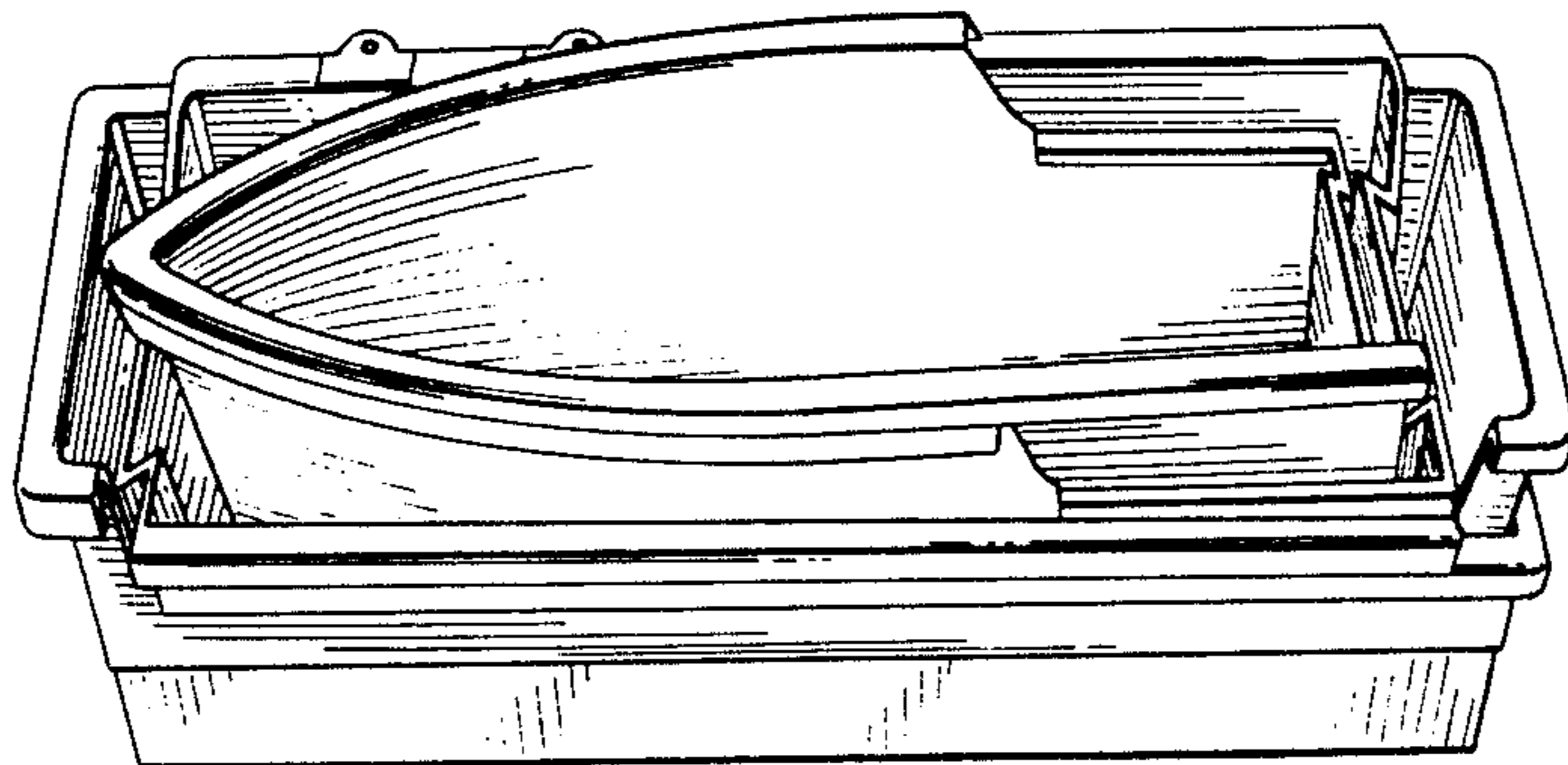

FIG. 2

