

[54] COMBINED AIR PRESSURE GAUGE AND DUAL TIRE AIR FILLING DEVICE

[76] Inventor: Chauncey B. Eller, 23100 Vista Grande Way, Colton, Calif. 92324

[**] Term: 14 Years

[21] Appl. No.: 925,223

[22] Filed: Jul. 17, 1978

[51] Int. Cl. D10-04

[52] U.S. Cl. D10/86

[58] Field of Search D10/85, 86; 137/227; 73/146, 146.2, 146.3, 146.8

[56] References Cited

U.S. PATENT DOCUMENTS

D. 179,526	1/1957	Price	D10/86
D. 247,429	3/1978	Teal	D10/86
1,894,648	1/1933	Wahl	D10/86 X
1,985,759	12/1934	Baumgartner	137/227 X
3,429,332	2/1969	Mazeika	137/227

3,739,637 6/1973 Novak 73/146.3

FOREIGN PATENT DOCUMENTS

661669 7/1929 France 137/227

Primary Examiner—Nelson O. Holtje
Attorney, Agent, or Firm—William C. Babcock

[57] CLAIM

The ornamental design for a combined air pressure gauge and dual tire air filling device, as shown and described.

DESCRIPTION

FIG. 1 is a top perspective view of a combined air pressure gauge and dual tire air filling device showing my new design;

FIG. 2 is a top plan view thereof;

FIG. 3 is a bottom plan view thereof;

FIG. 4 is a far side elevational view thereof;

FIG. 5 is a near side elevational view thereof;

FIG. 6 is a left end elevational view thereof; and

FIG. 7 is a right end elevational view thereof.

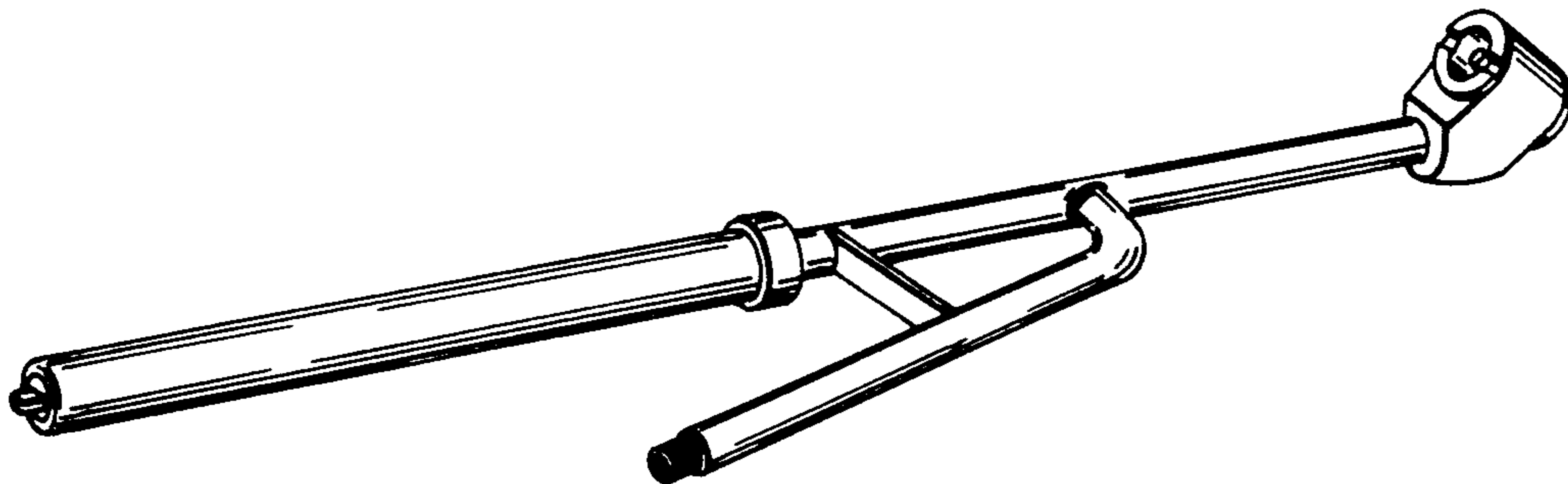

FIG. 1

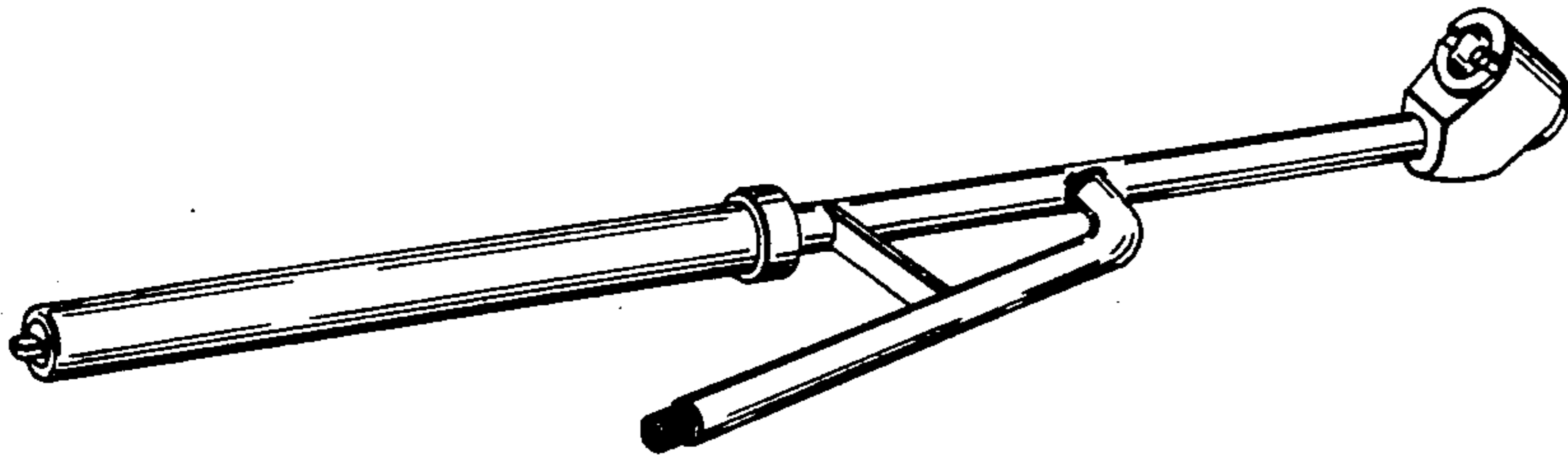

FIG. 2

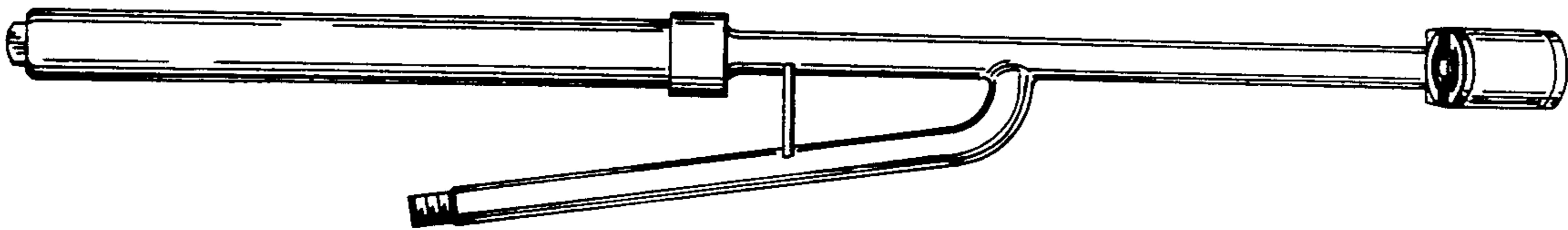

FIG. 3

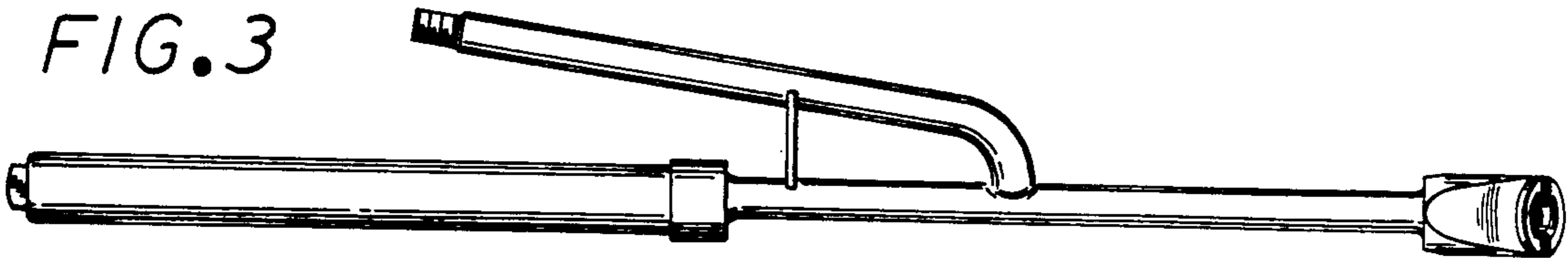

FIG. 4

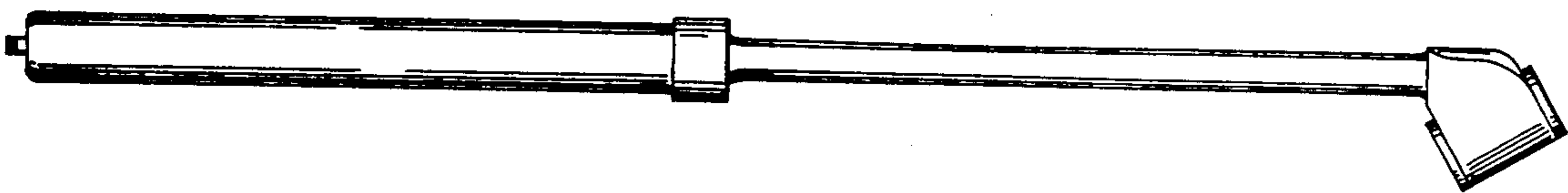

FIG. 5

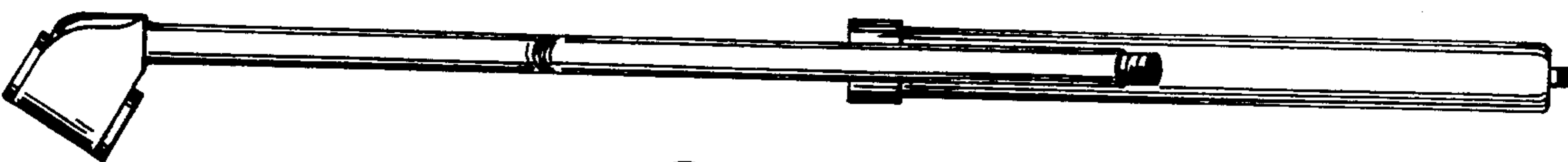

FIG. 6

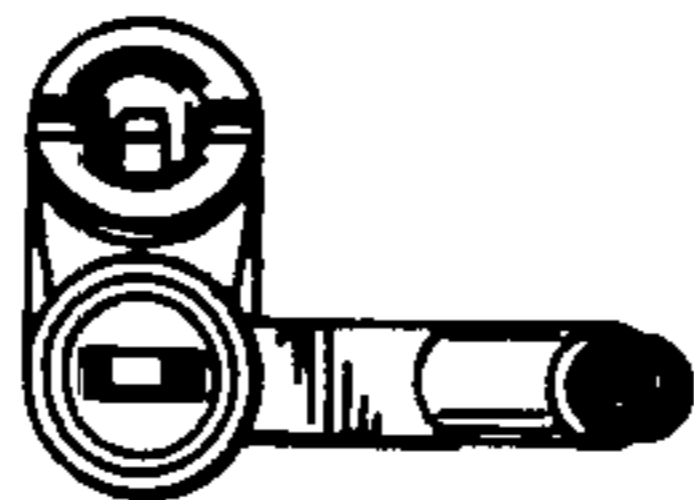

FIG. 7

