

[54] MOTORCYCLE HUB LOCK

[76] Inventor: Richard J. Fouhy, 8980 Westhill Rd., Lakeside, Calif. 92040

[**] Term: 14 Years

[21] Appl. No.: 940,180

[22] Filed: Sep. 7, 1978

[51] Int. Cl. D8-07

[52] U.S. Cl. D8/331

[58] Field of Search D8/331, 333, 343; 70/58, 226, 227, 233, 236; 46/27, 28, 29

[56] References Cited

U.S. PATENT DOCUMENTS

3,760,620 9/1973 Robles 70/226
3,797,284 3/1974 Grossman 70/58

Primary Examiner—James M. Gandy

Attorney, Agent, or Firm—John L. Haller

[57] CLAIM

The ornamental design for a motorcycle hub lock, as shown and described.

DESCRIPTION

FIG. 1 is a perspective view of a motorcycle hub lock showing my new design;

FIG. 2 is a front elevational view thereof;

FIG. 3 is end elevational view thereof;

FIG. 4 is a top plan view thereof;

FIG. 5 is perspective view of a motorcycle hub lock showing a second embodiment of my new design;

FIG. 6 is an end elevational view of FIG. 5;

FIG. 7 is a perspective view of a motorcycle hub lock showing a third embodiment of my new design; and

FIG. 8 is an end elevational view of FIG. 7.

The undisclosed end of the lock is understood to be flat and unornamented.

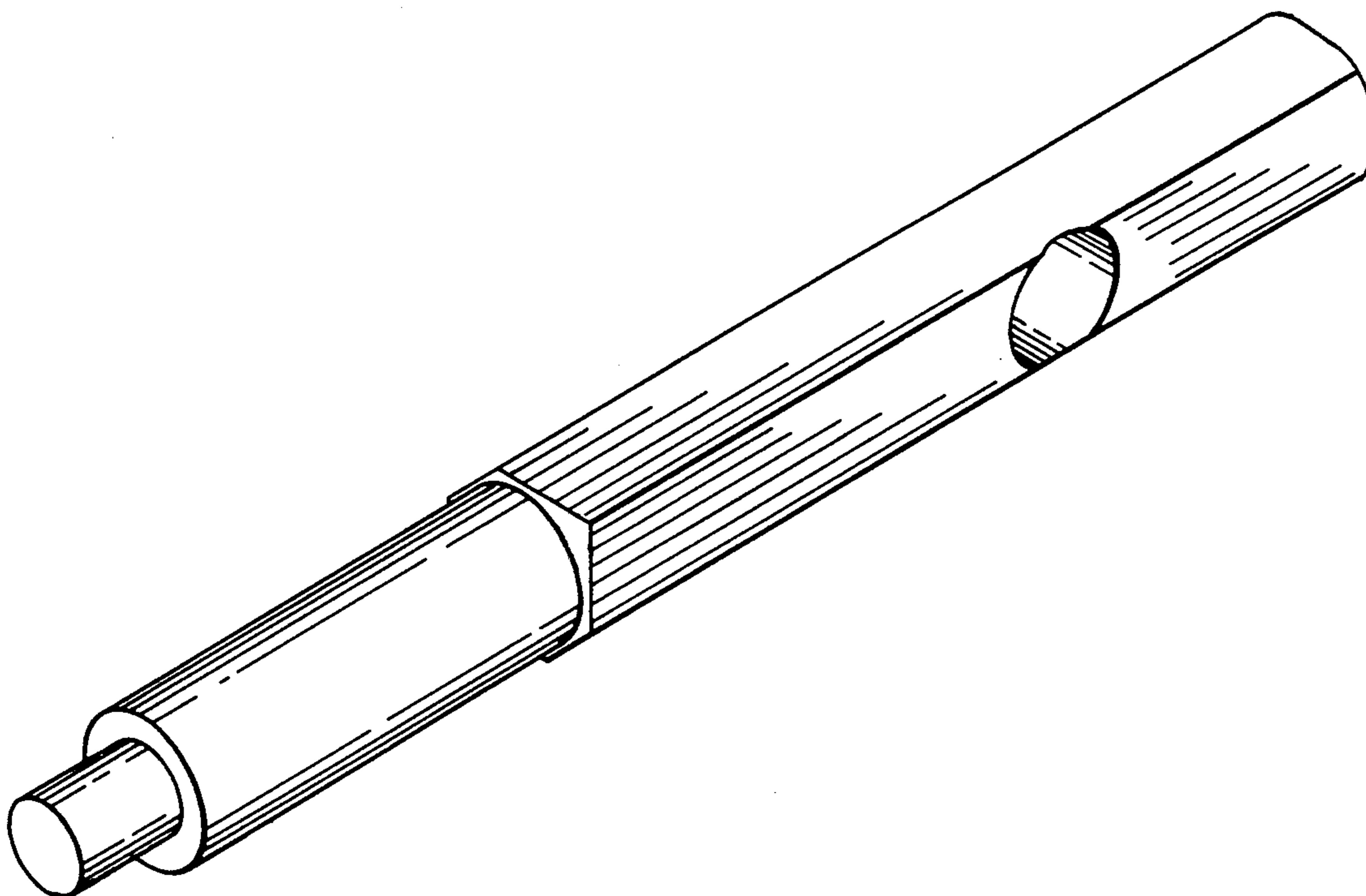

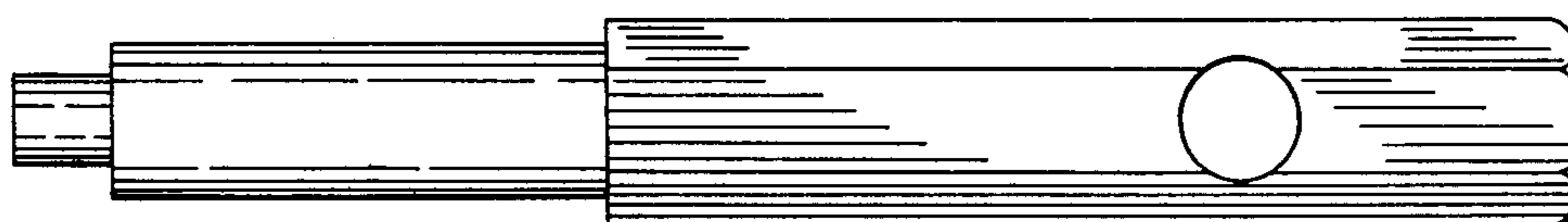
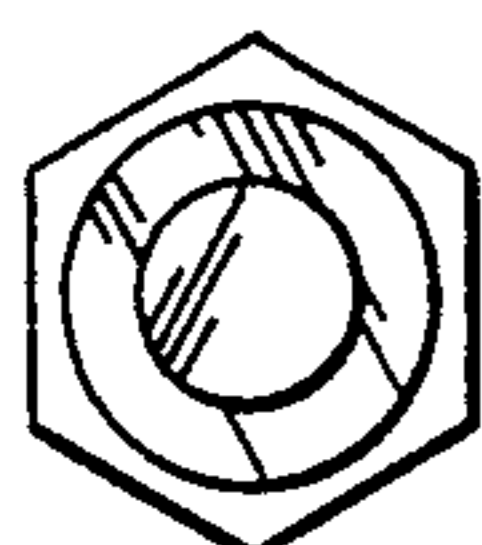
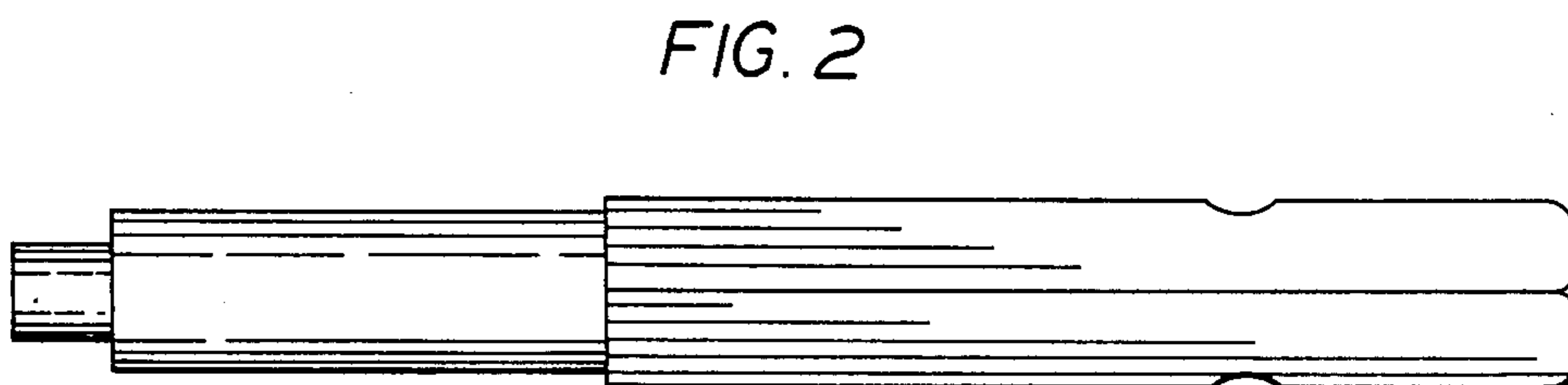
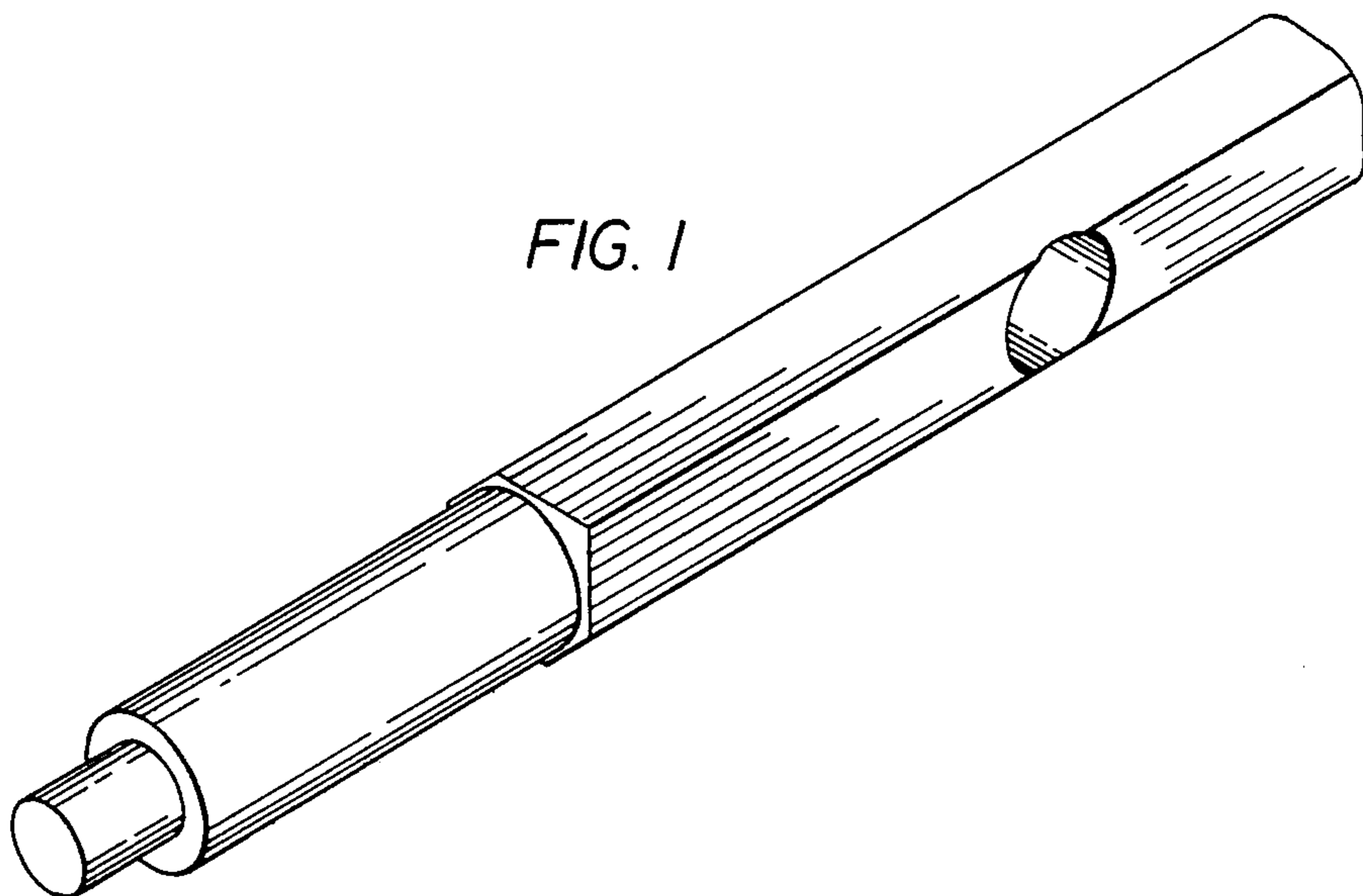

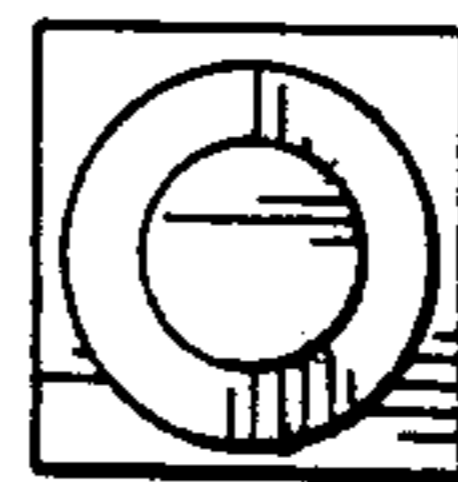
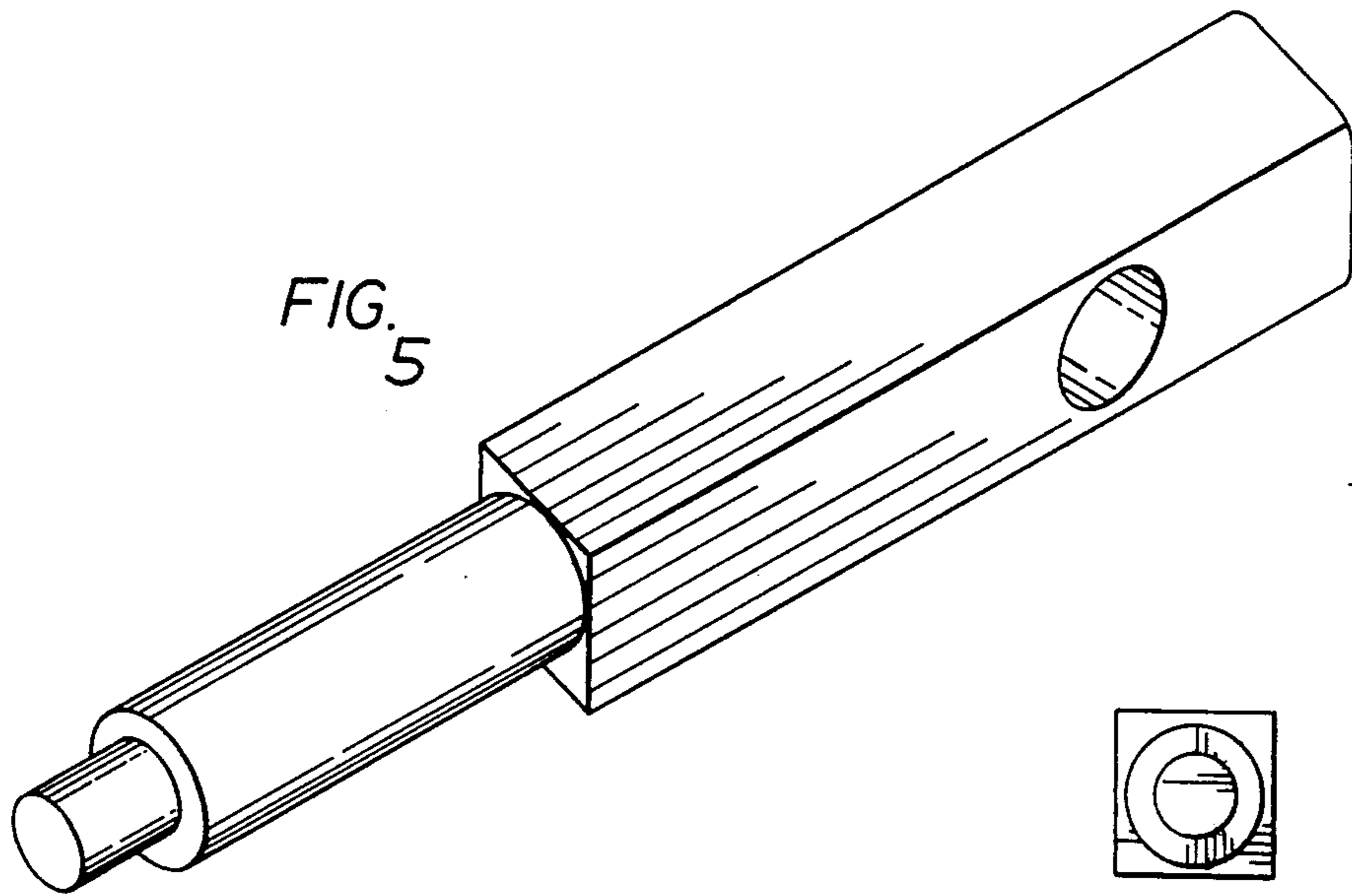

FIG. 6

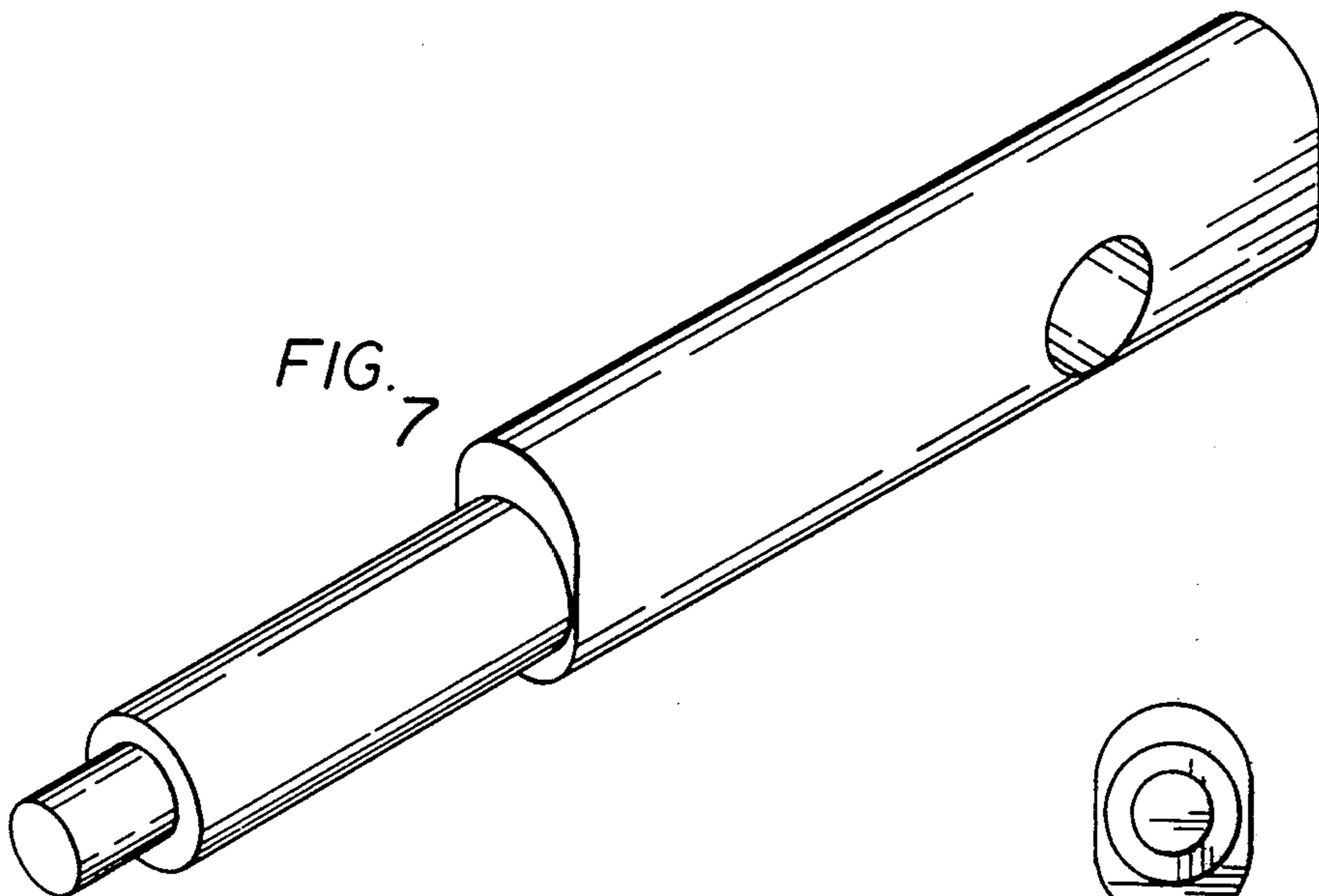

FIG. 8