

[54] RAILROAD RESTAURANT

[76] Inventor: Gary M. Levin, 940 E. 19 St., Brooklyn, N.Y. 11230

[\*\*] Term: 14 Years

[21] Appl. No.: 145,048

[22] Filed: Apr. 30, 1980

Related U.S. Application Data

[62] Division of Ser. No. 928,387, Jul. 27, 1978.

[51] Int. Cl. .... D25-03

[52] U.S. Cl. .... D25/11; D25/17; D25/22; D25/23; D25/33; D25/52

[58] Field of Search ..... D25/1, 3, 7, 11, 17, D25/22, 23, 24, 25, 26, 33, 52; 52/73; D12/101, 102, 103

[56] References Cited

U.S. PATENT DOCUMENTS

|            |        |              |         |
|------------|--------|--------------|---------|
| D. 115,683 | 7/1939 | Bemis .....  | D25/11  |
| D. 227,356 | 6/1973 | Winter ..... | D25/11  |
| 3,673,749  | 7/1972 | Allen .....  | 52/73   |
| 4,098,036  | 7/1978 | Spöler ..... | 52/73 X |

OTHER PUBLICATIONS

Interiors, Oct. 1976, p. 88, Victoria Station Restaurant. Progressive Architecture, Apr. 1977, p. 112, Building at lower right.

Primary Examiner—A. Hugo Word

Attorney, Agent, or Firm—Howard Alan Taishoff

[57] CLAIM

The ornamental design for a railroad restaurant, as shown and described.

DESCRIPTION

FIG. 1 is a front perspective view of the right side of a railroad restaurant according to my new design;  
 FIG. 2 is a front perspective view of the left side of the railroad restaurant of FIG. 1;  
 FIG. 3 is a top view of the railroad restaurant of FIG. 1;  
 FIG. 4 is an elevational view of the right side shown in FIG. 1;  
 FIG. 5 is an elevational view of the left side shown in FIG. 2;  
 FIG. 6 is an elevational view of the front shown in FIG. 1;  
 FIG. 7 is an elevational view of the rear of the railroad restaurant of FIG. 1.

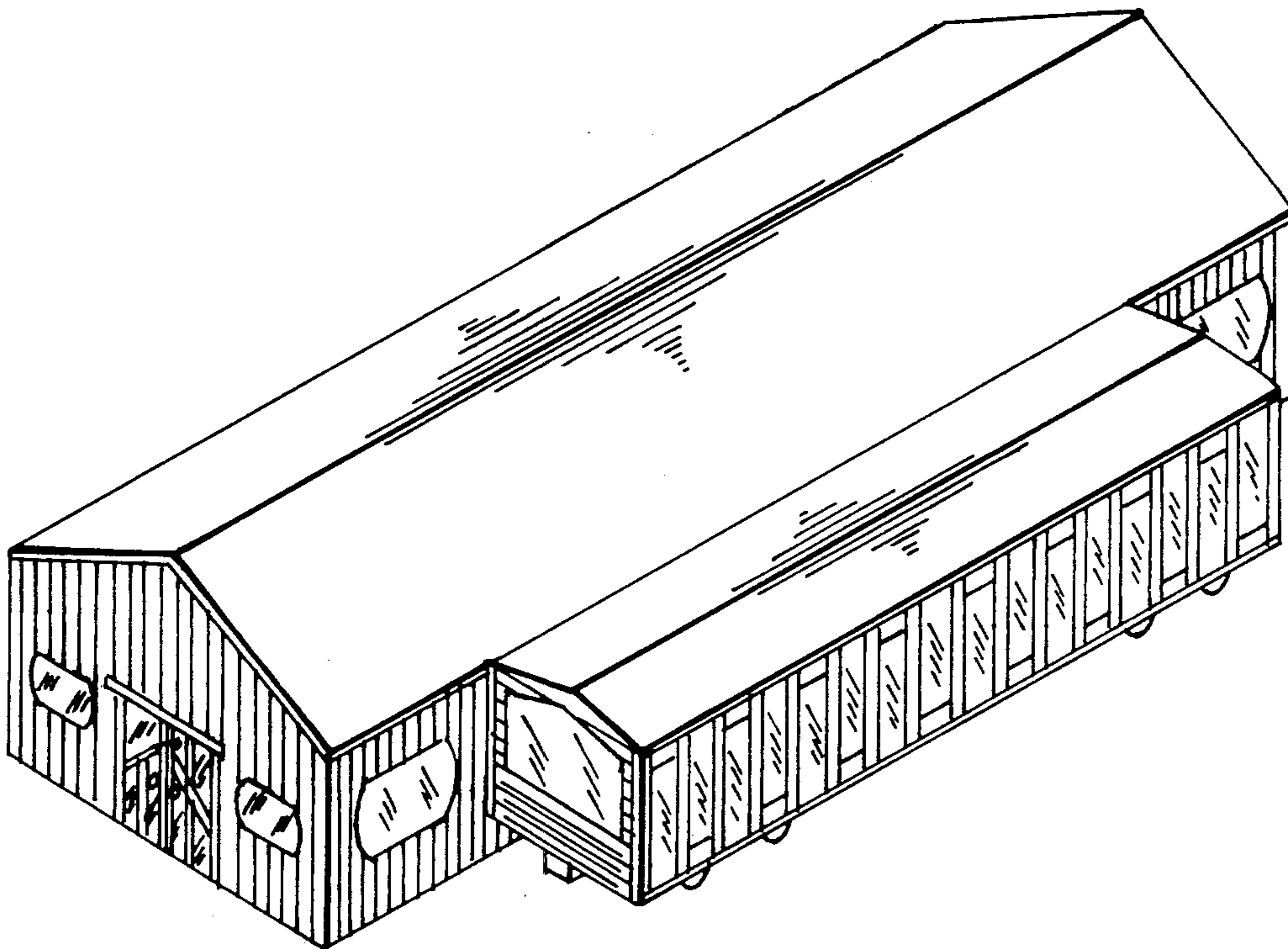

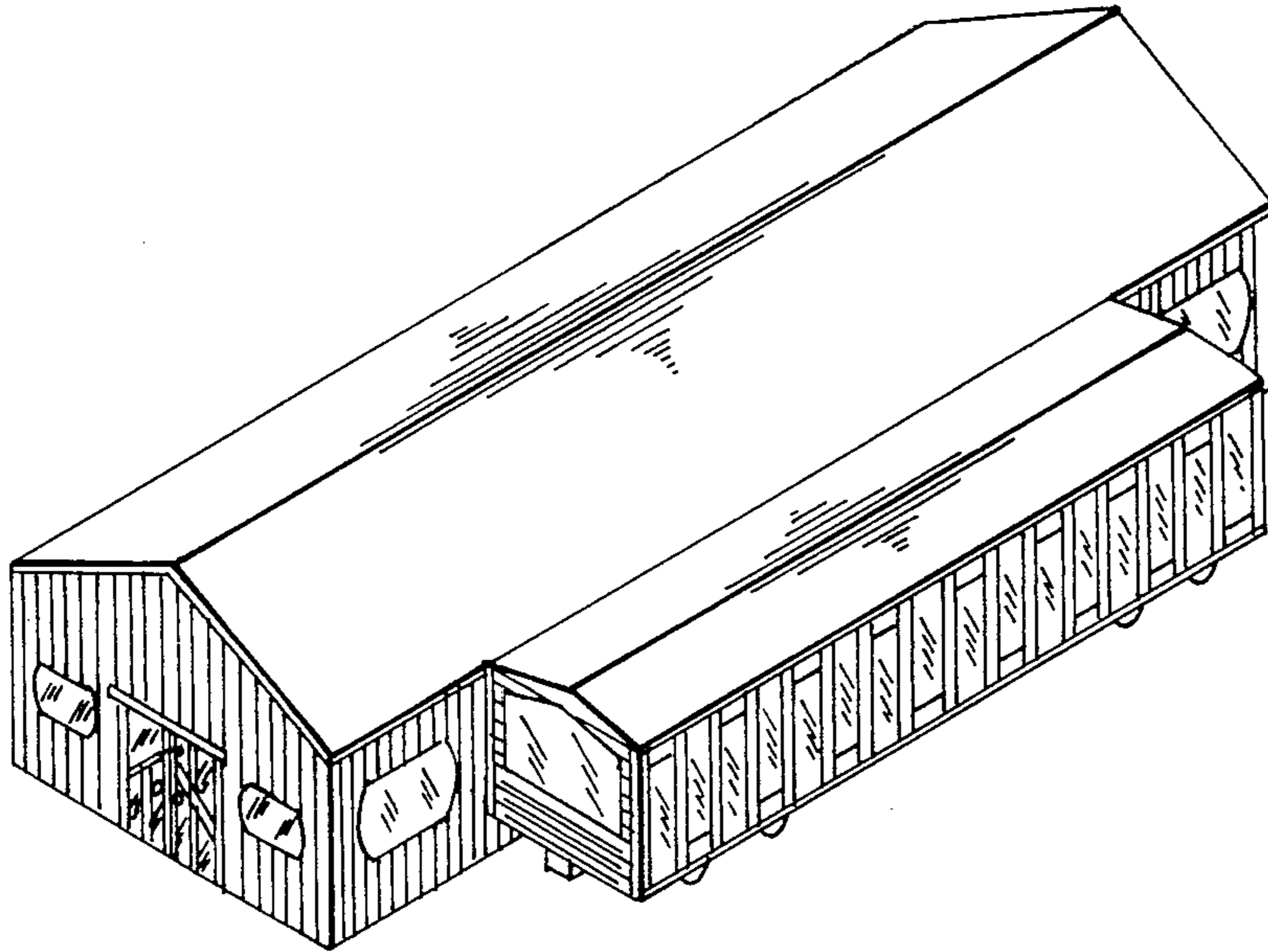

Figure 1

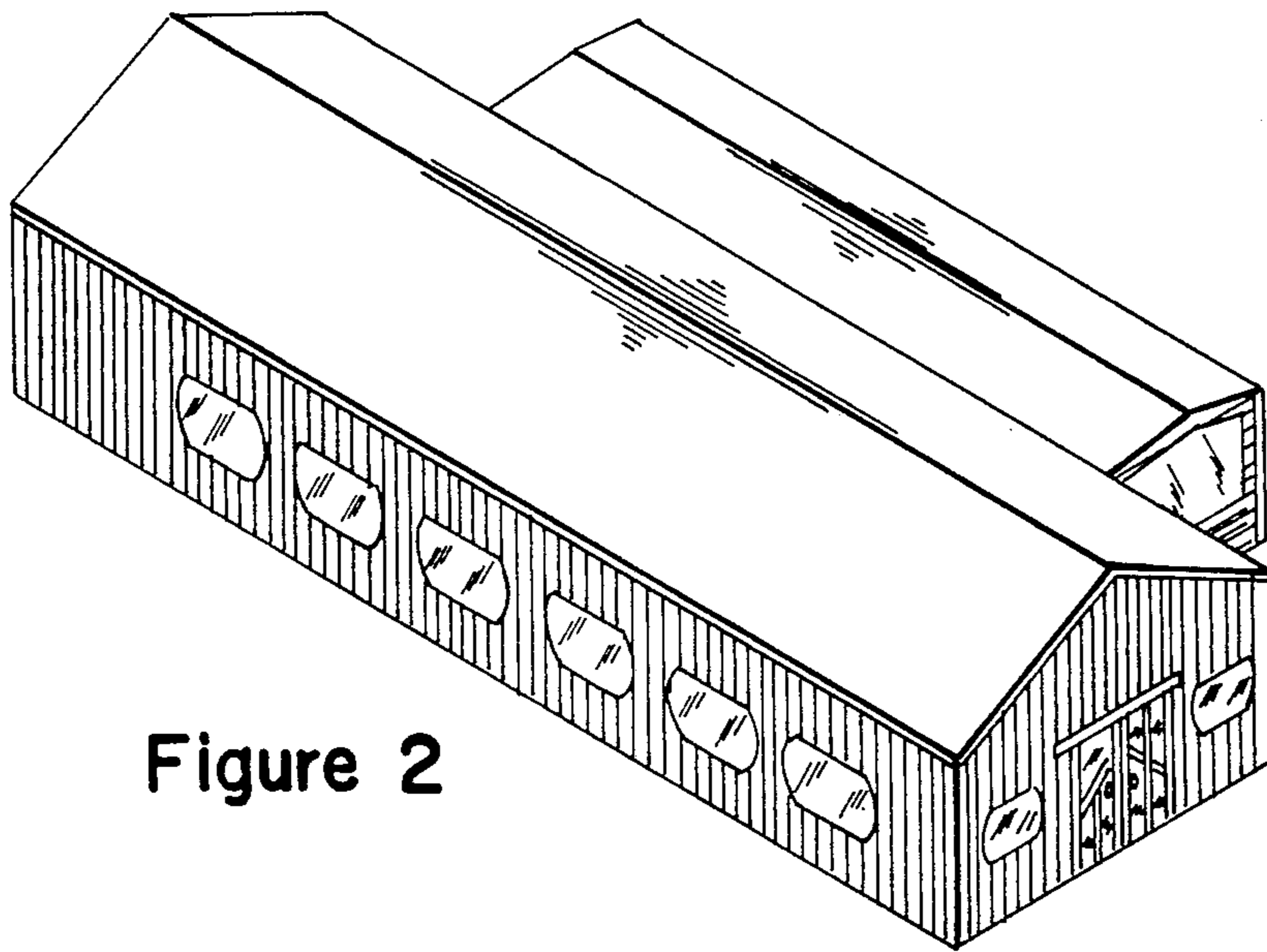

Figure 2

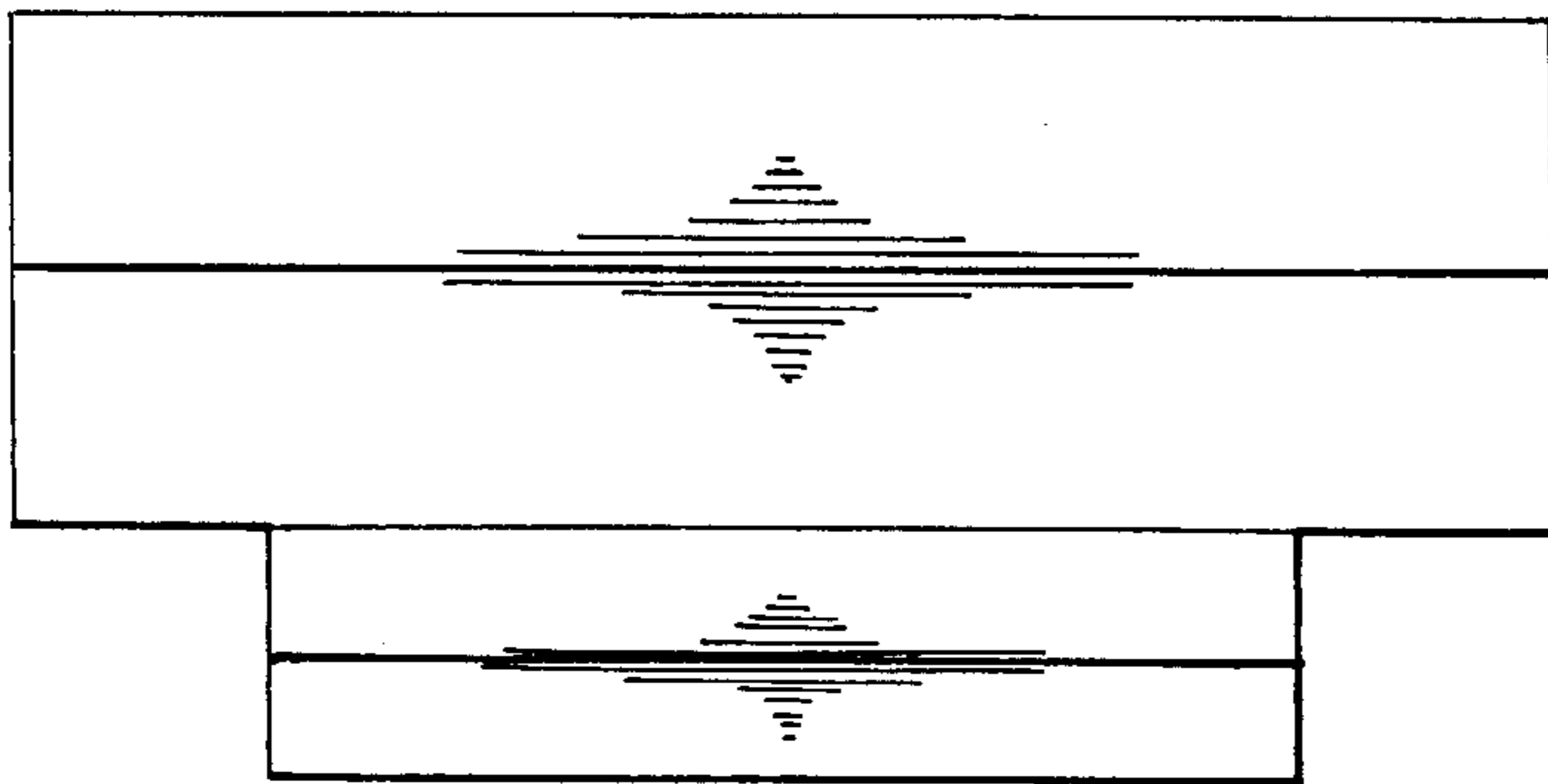

Figure 3

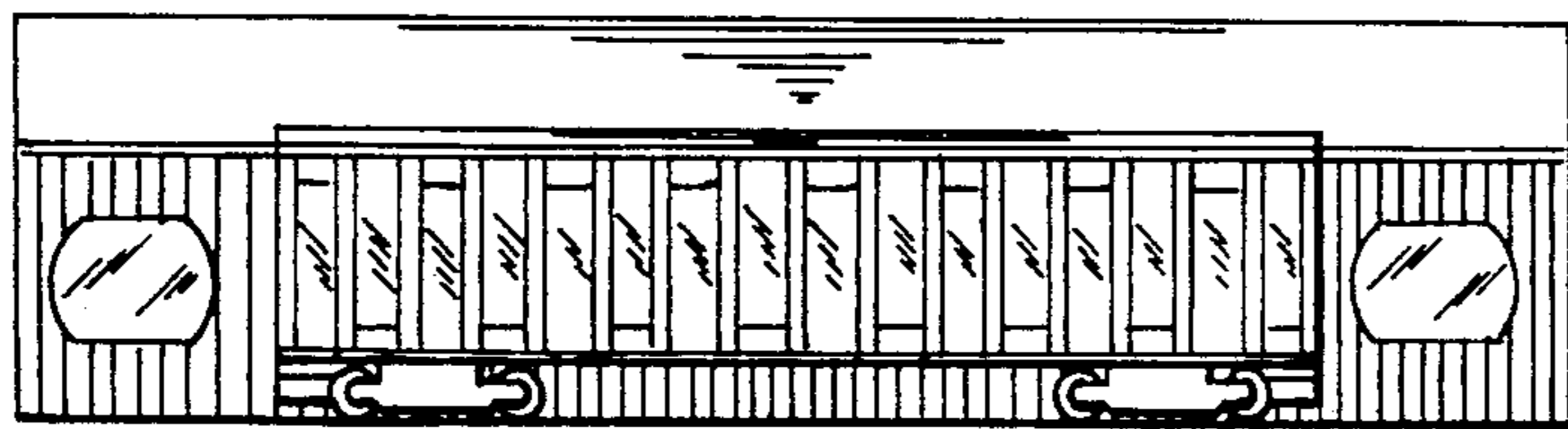

Figure 4

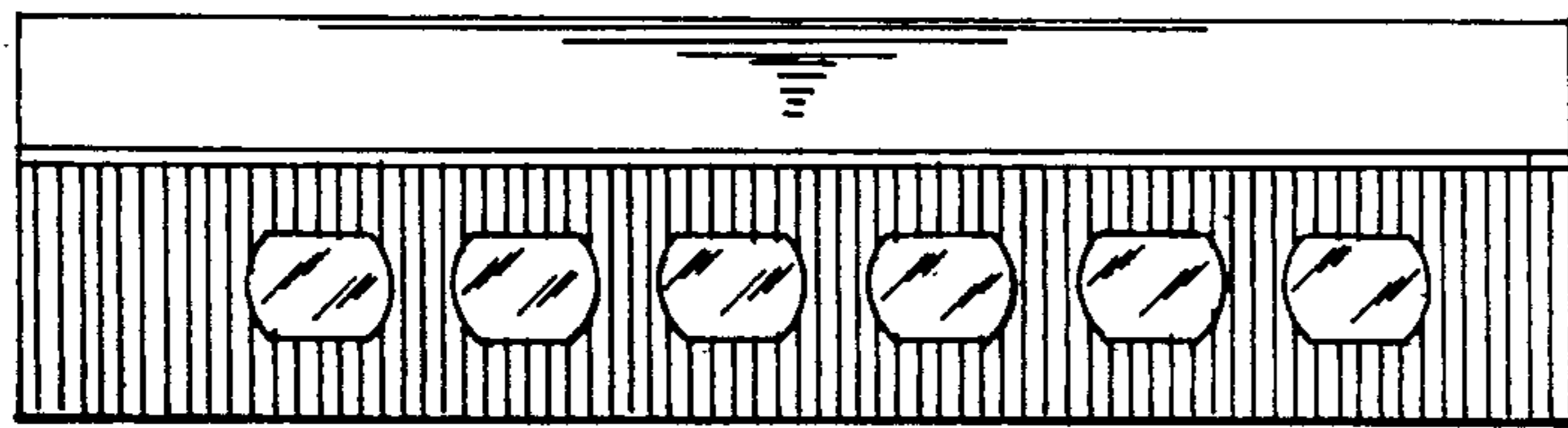

Figure 5

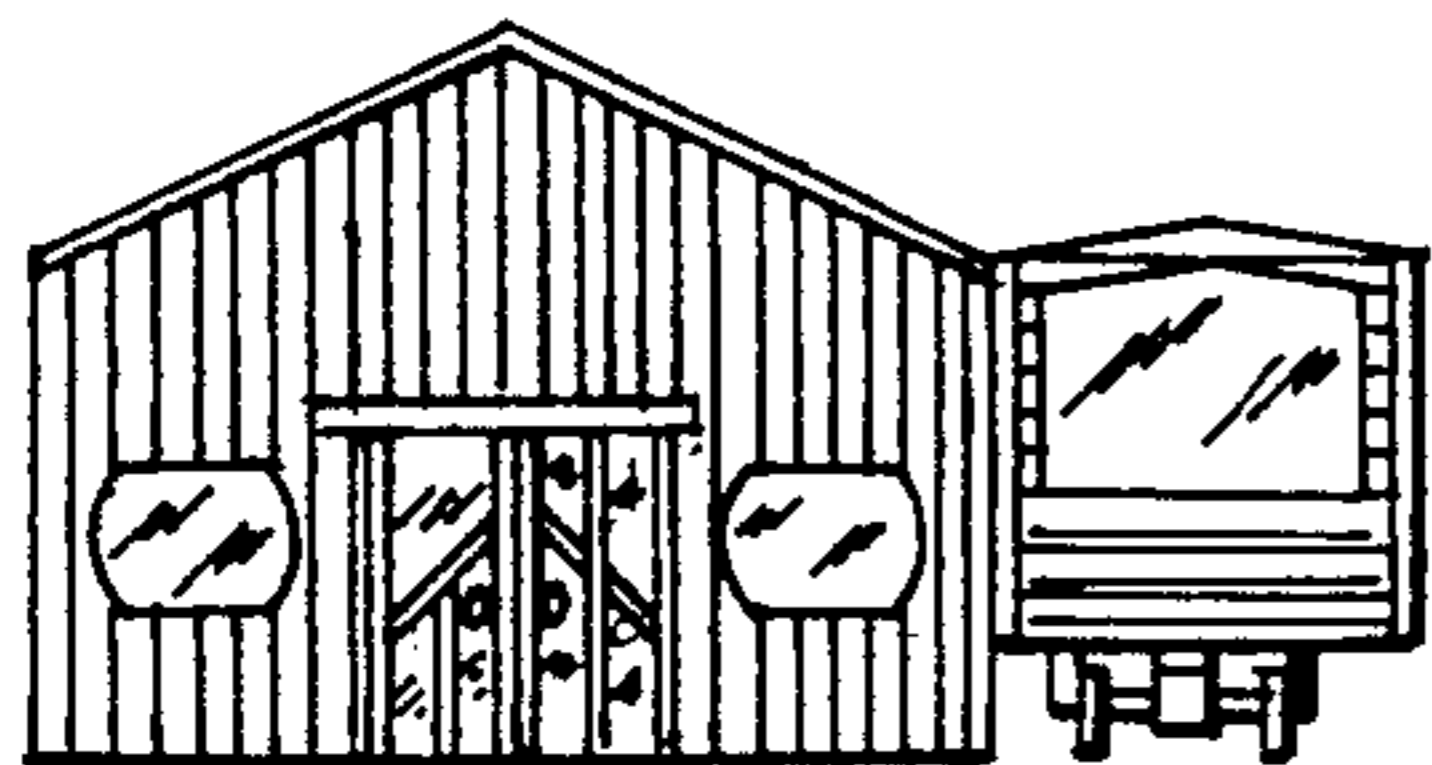

Figure 6

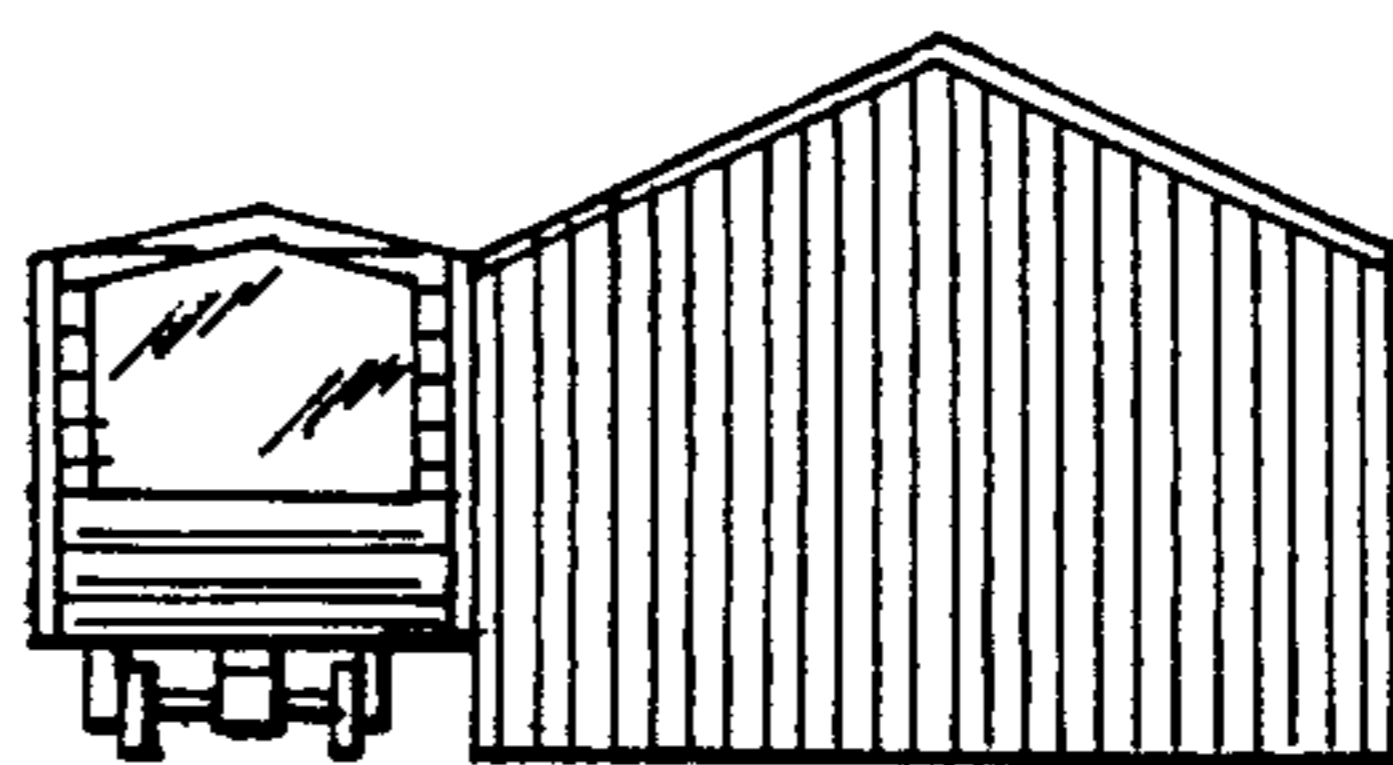

Figure 7