

[54] WIRE WHEEL CENTER FOR A TRUCK
[76] Inventor: Lee Simpson, 220 Clovis Ave., Apt.
102, Clovis, Calif. 93706
[**] Term: 14 Years
[21] Appl. No.: 13,620
[22] Filed: Feb. 21, 1979
[51] Int. Cl. D12-16
[52] U.S. Cl. D12/205
[58] Field of Search D12/205; 301/95, 95 B,
301/37 R, 37 SS, 63 R, 64 R, 64 SD, 65, 66, 73,
54, 58

[56] **References Cited**
U.S. PATENT DOCUMENTS
D. 170,463 9/1953 Jenkins, Jr. D12/205

OTHER PUBLICATIONS
Motor Trend, 7/77, p. 85, Wire Wheel, lower center of page.
Primary Examiner—James M. Gandy
Attorney, Agent, or Firm—Huebner & Worrel

[57] **CLAIM**
The ornamental design for a wire wheel center for a truck, as shown and described.

DESCRIPTION
FIG. 1 is a front elevational view of the wire wheel center for a truck showing my new design, it being understood that the broken lines in the drawing are for illustrative purposes only.
FIG. 2 is a rear elevational view thereof.
FIG. 3 is a side elevational view thereof.

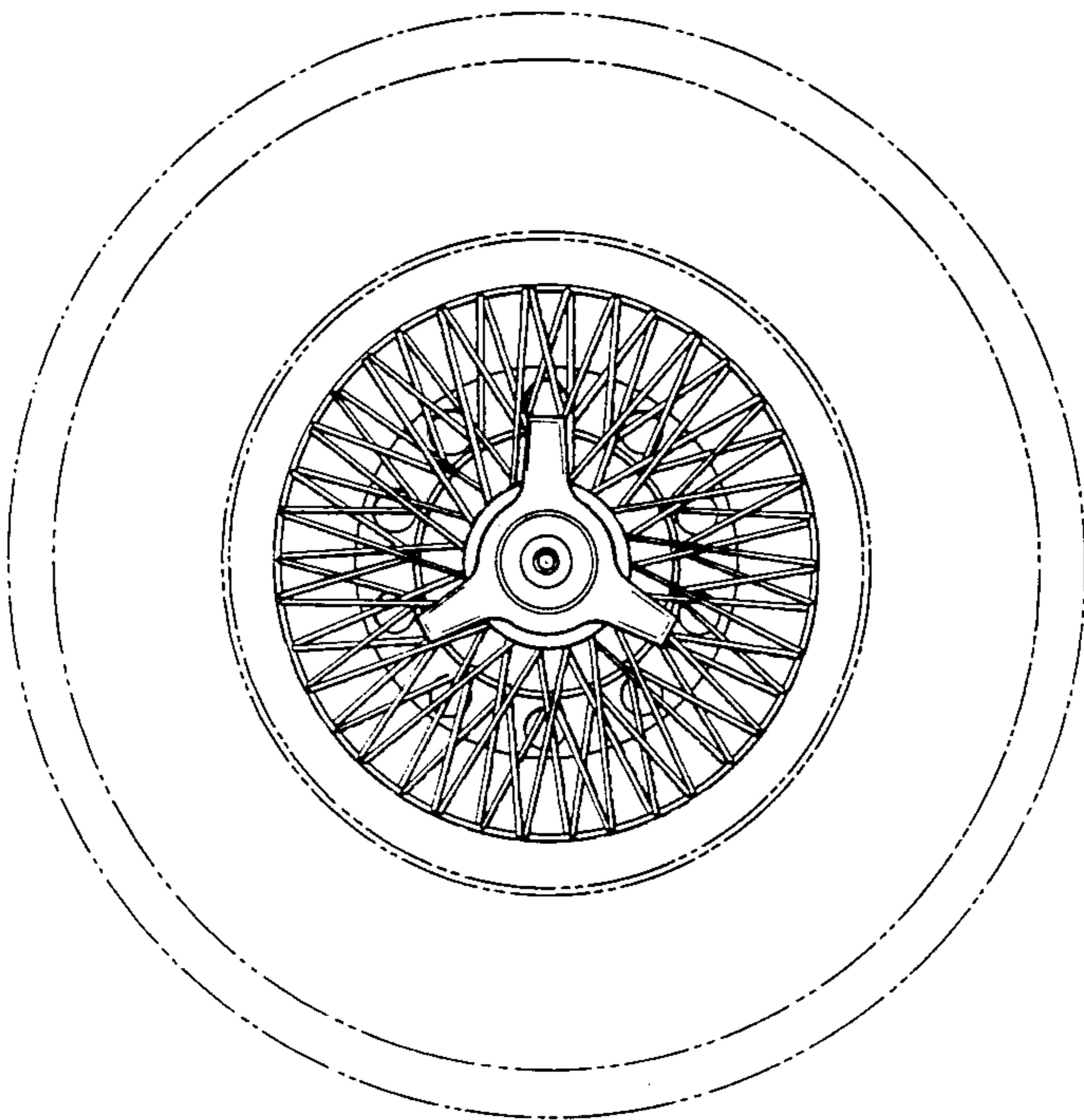

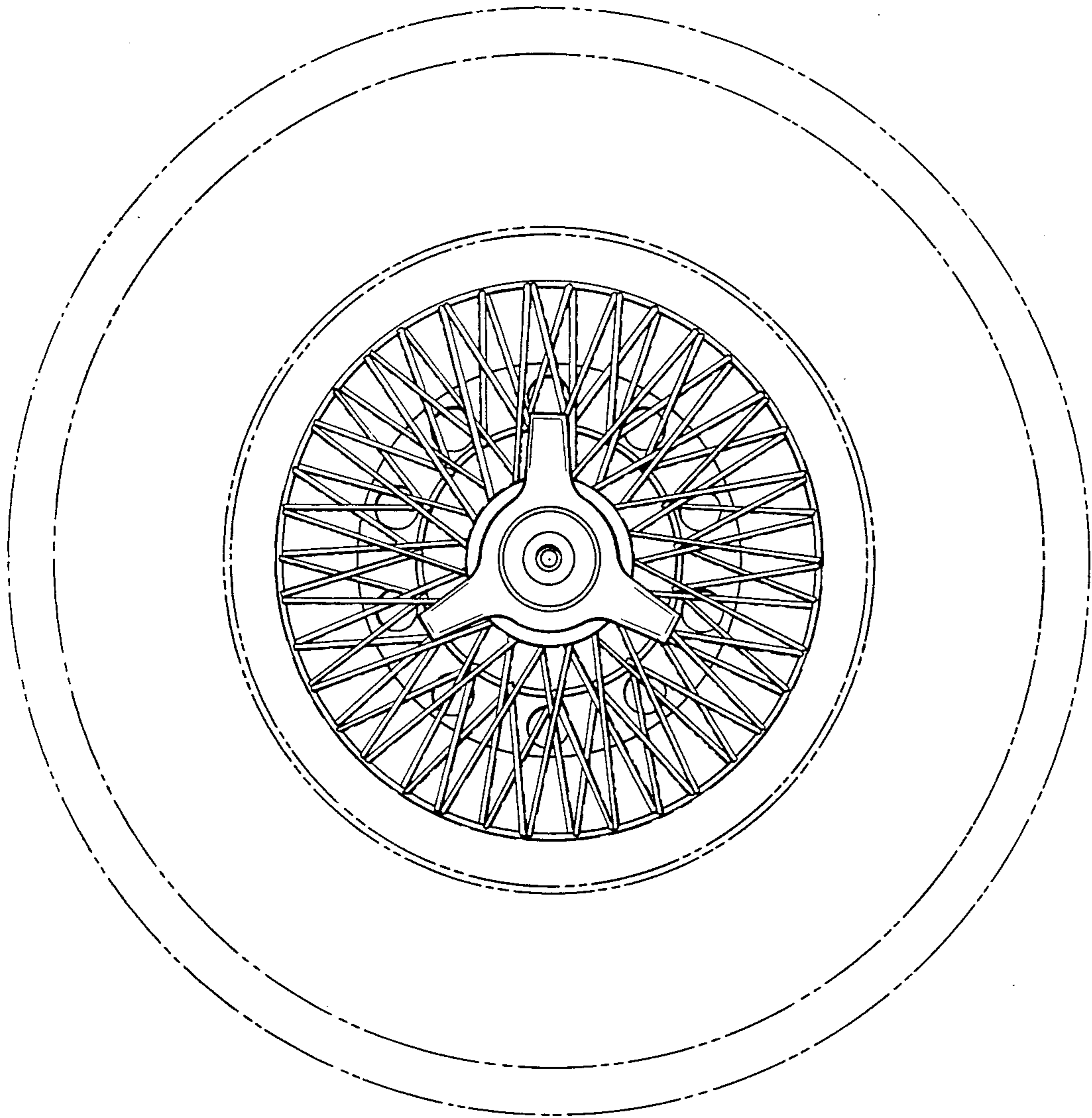

FIG. 1

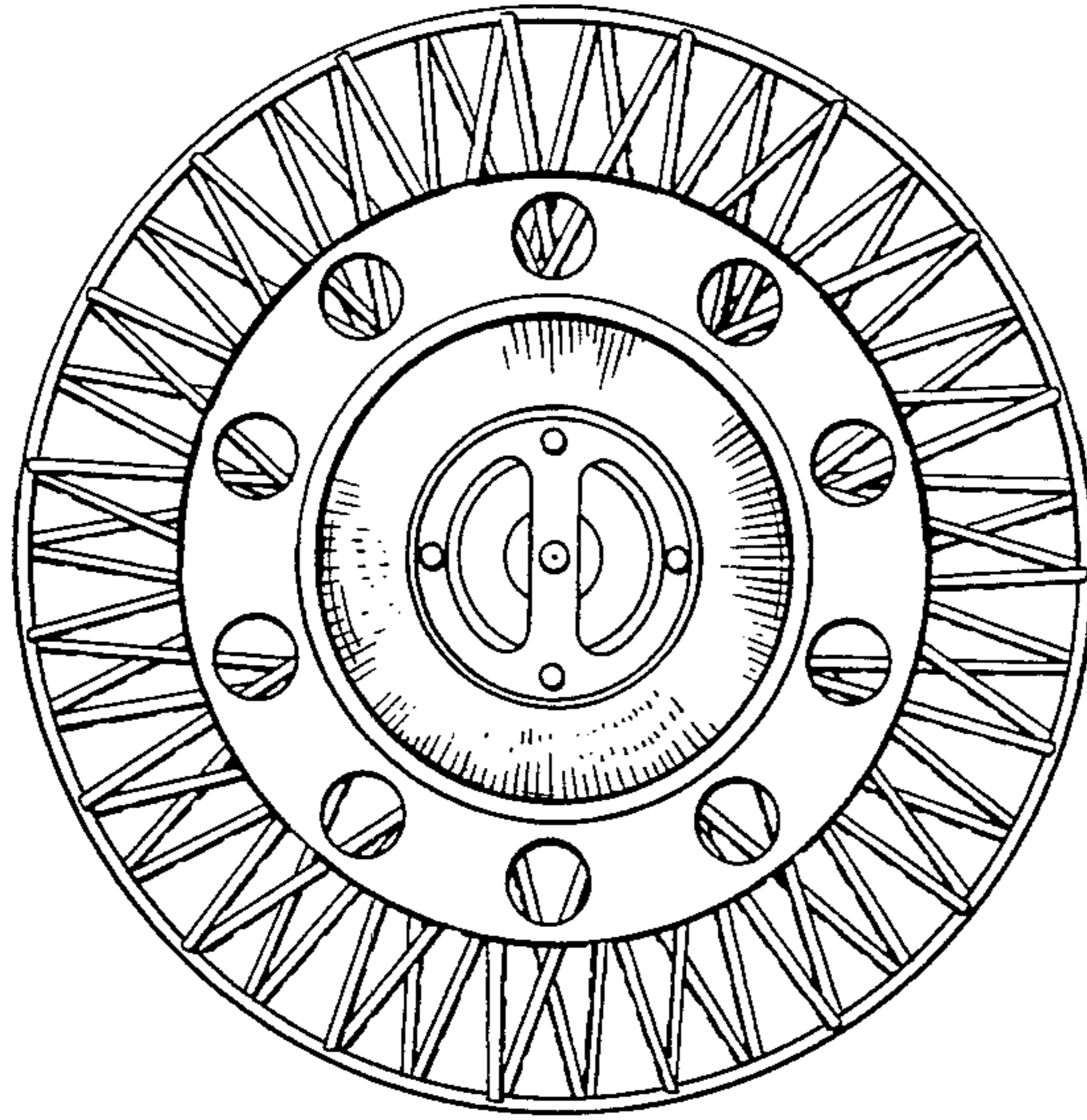

FIG. 2

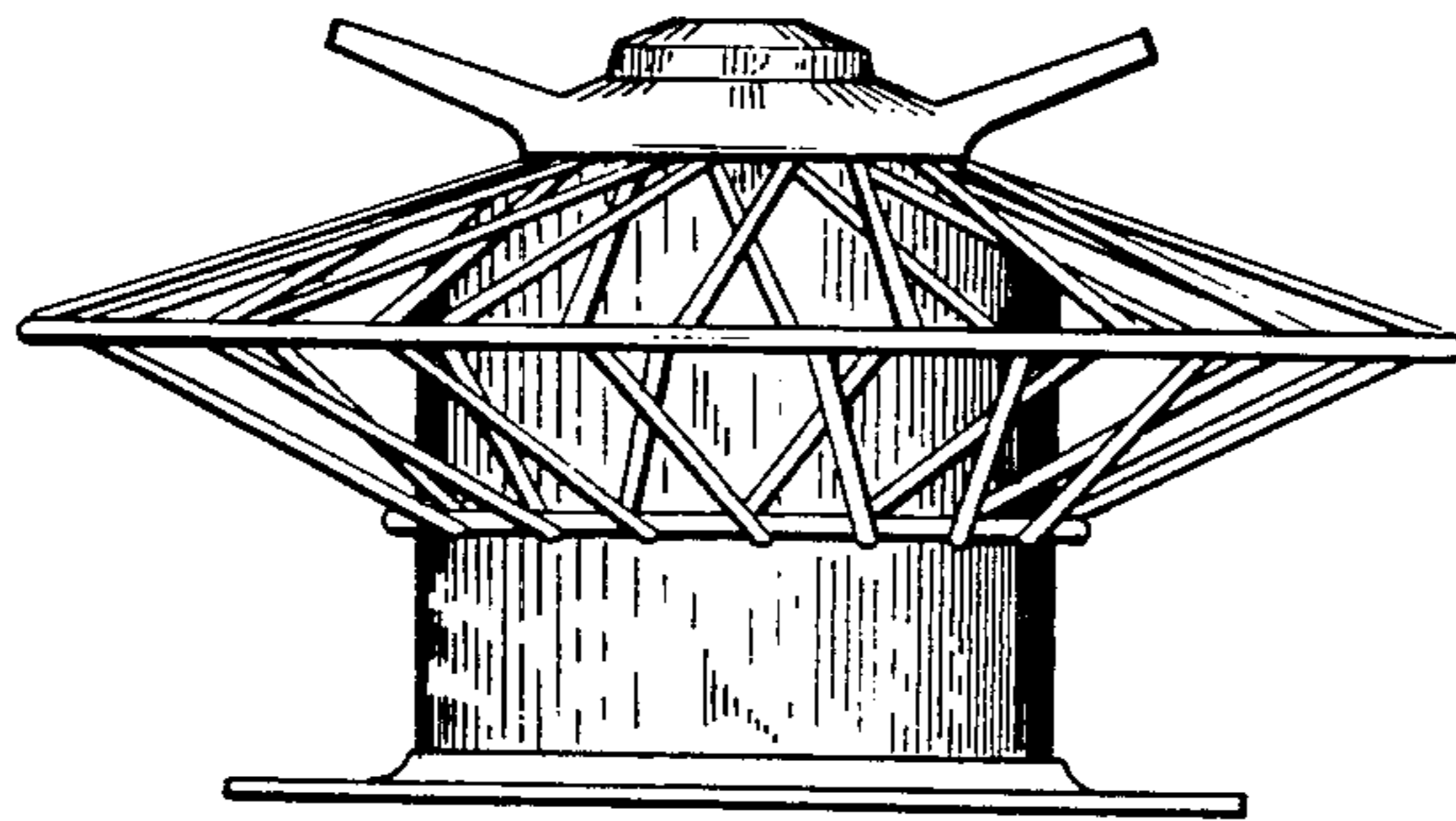

FIG. 3