

[54] COMBINED UPPER HULL AND BOAT INTERIOR

[75] Inventor: Charles Bednar, Oak Park, Ill.

[73] Assignee: Viking Boat Company, Inc., Middlebury, Ind.

[\*\*] Term: 14 Years

[21] Appl. No.: 966,764

[22] Filed: Dec. 5, 1978

[51] Int. Cl. .... D12-06

[52] U.S. Cl. .... D12/318

[58] Field of Search ..... D12/62, 70; 9/1.1, 6 W, 9/6 P, 6 M, 6 R

[56] References Cited

U.S. PATENT DOCUMENTS

D. 204,523 4/1966 Cole ..... D12/62  
D. 251,778 5/1979 Trabue ..... D12/70

Primary Examiner—Sam Rosen

[57] CLAIM

The ornamental design for a combined upper hull and boat interior, as shown and described.

DESCRIPTION

FIG. 1 is a perspective view of a combined upper hull and boat interior showing my new design; FIG. 2 is a side elevational view thereof; FIG. 3 is a top plan view thereof; FIG. 4 is a front elevation view thereof; and FIG. 5 is a rear elevation view thereof. The bottom of the boat is shown in dashed lines in FIGS. 2, 4 and 5 for illustrative purposes only and does not form part of my claimed design.

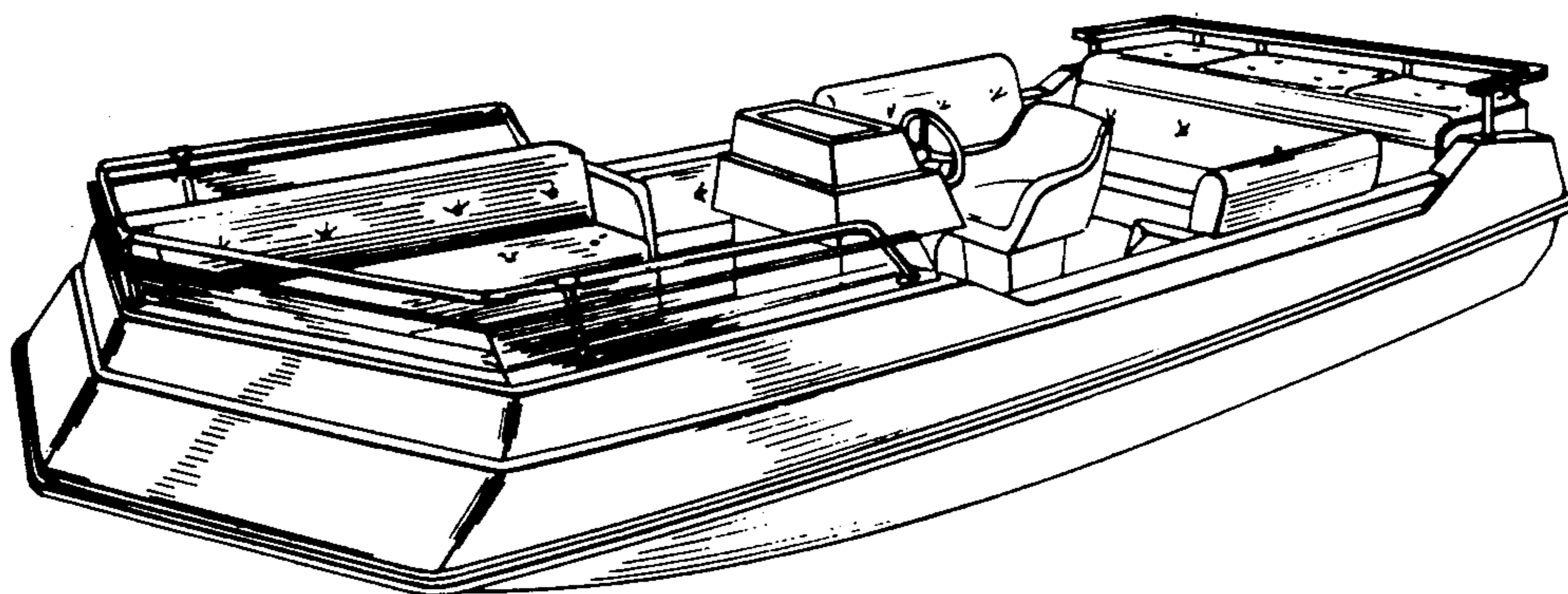

Fig. 1

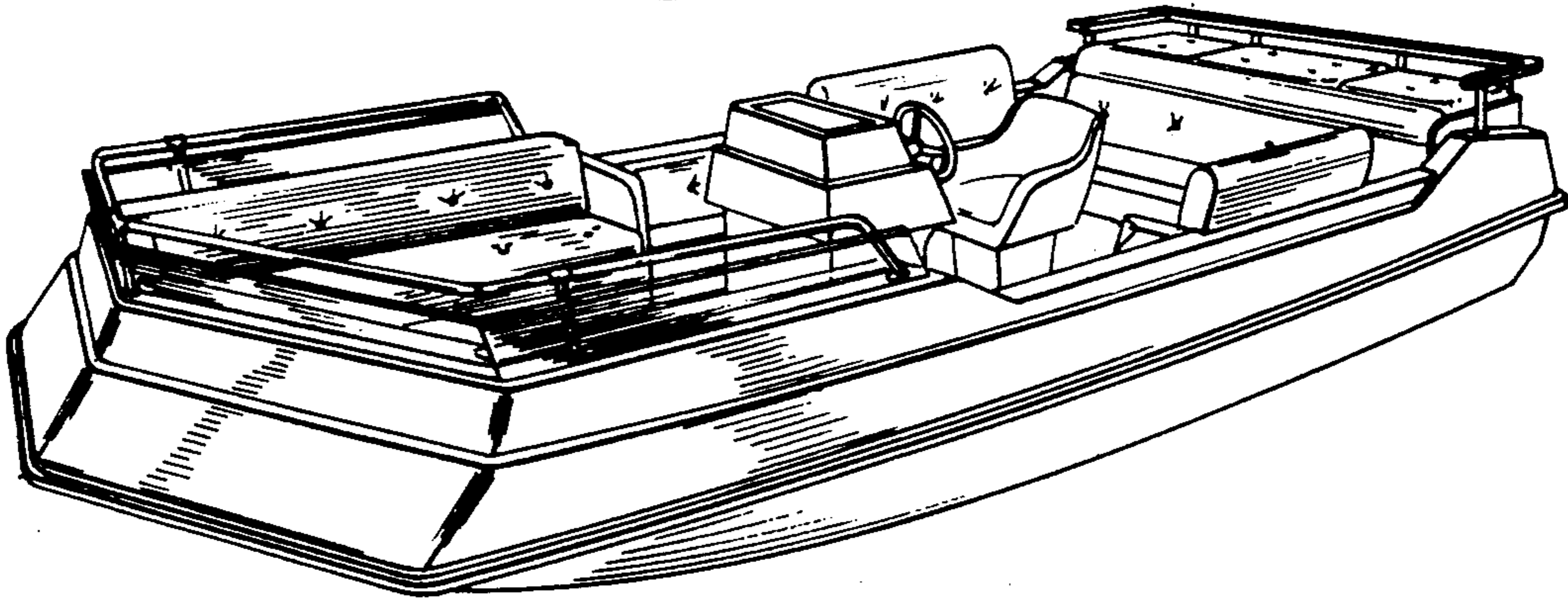

Fig. 2

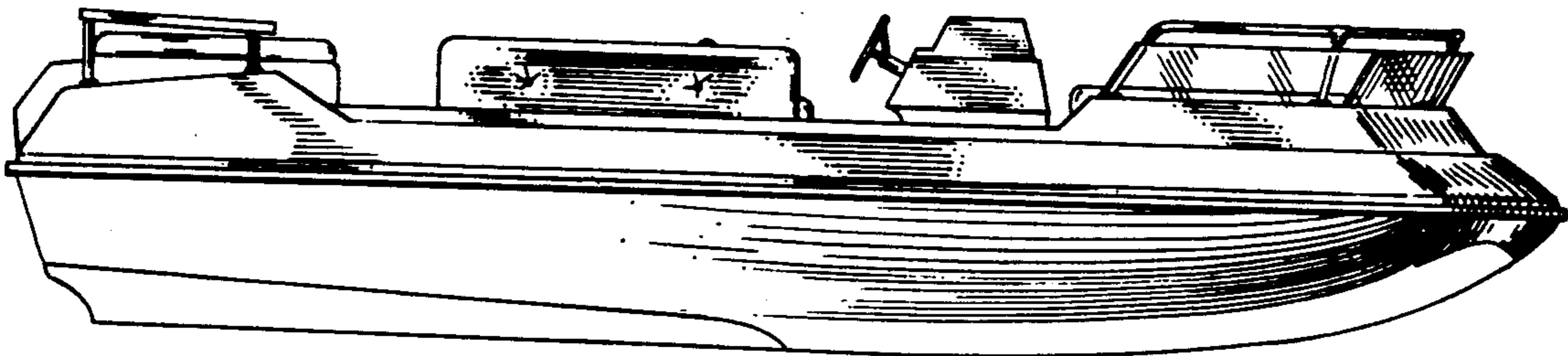

Fig. 3

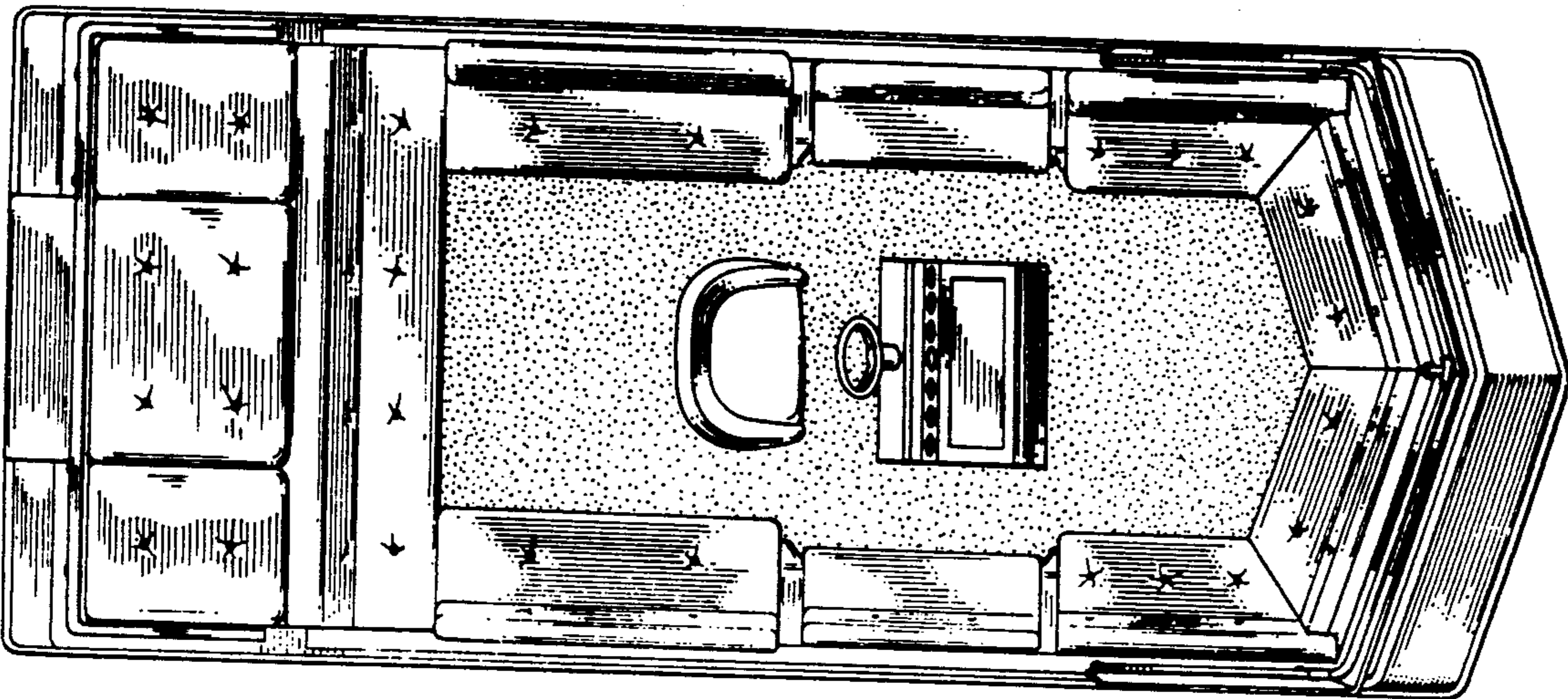

Fig. 4

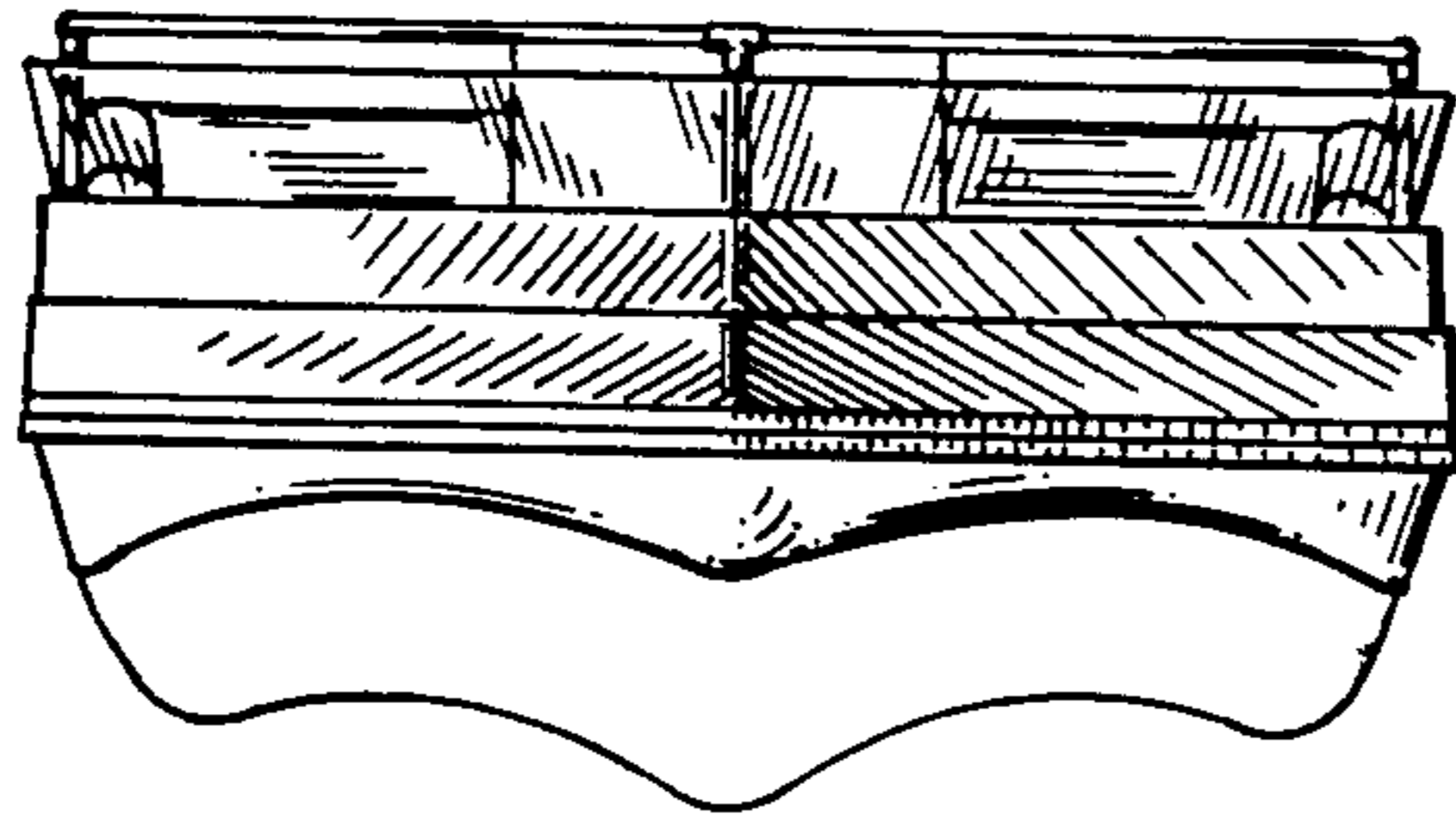

Fig. 5

