

[54] PORTABLE EASEL, SEAT AND CARRYING CASE COMBINATION

2,372,077 3/1945 Glinecki 297/156
3,765,719 10/1973 Silver 297/139

[76] Inventor: Joseph Licastro, II, 7329 Hooper Ave., Bakersfield, Calif. 93308

Primary Examiner—Bruce W. Dunkins
Attorney, Agent, or Firm—Claude A. S. Hamrick

[**] Term: 14 Years

[57] CLAIM

[21] Appl. No.: 874,568

The ornamental design for a portable easel, seat and carrying case combination, substantially as shown and described.

[22] Filed: Feb. 2, 1978

DESCRIPTION

[51] Int. Cl. D6—05

FIG. 1 is a front perspective view of a portable easel, seat and carrying case combination showing my design in assembled position for use;

[52] U.S. Cl. D6/17

FIG. 2 is an elevational view thereof showing one of the two identical sides;

[58] Field of Search D6/17, 18, 26, 29, 55, D6/64, 180; 248/441, 457; 297/135, 139, 140, 141, 156, 17, 195

FIG. 3 is a rear elevational view;

[56] References Cited

U.S. PATENT DOCUMENTS

FIG. 4 is an upside down view showing the relationship between the seat and leg unit, the easel member having been omitted for convenience of illustration; and

FIG. 5 is a perspective view showing the painting easel mated together with the artist seat to form a carrying case.

D. 169,012	3/1953	Musacco	D6/17
D. 175,016	6/1955	Cote	D6/17
1,557,541	10/1925	Lynch et al.	297/156
1,951,960	3/1934	Anduaga	297/156

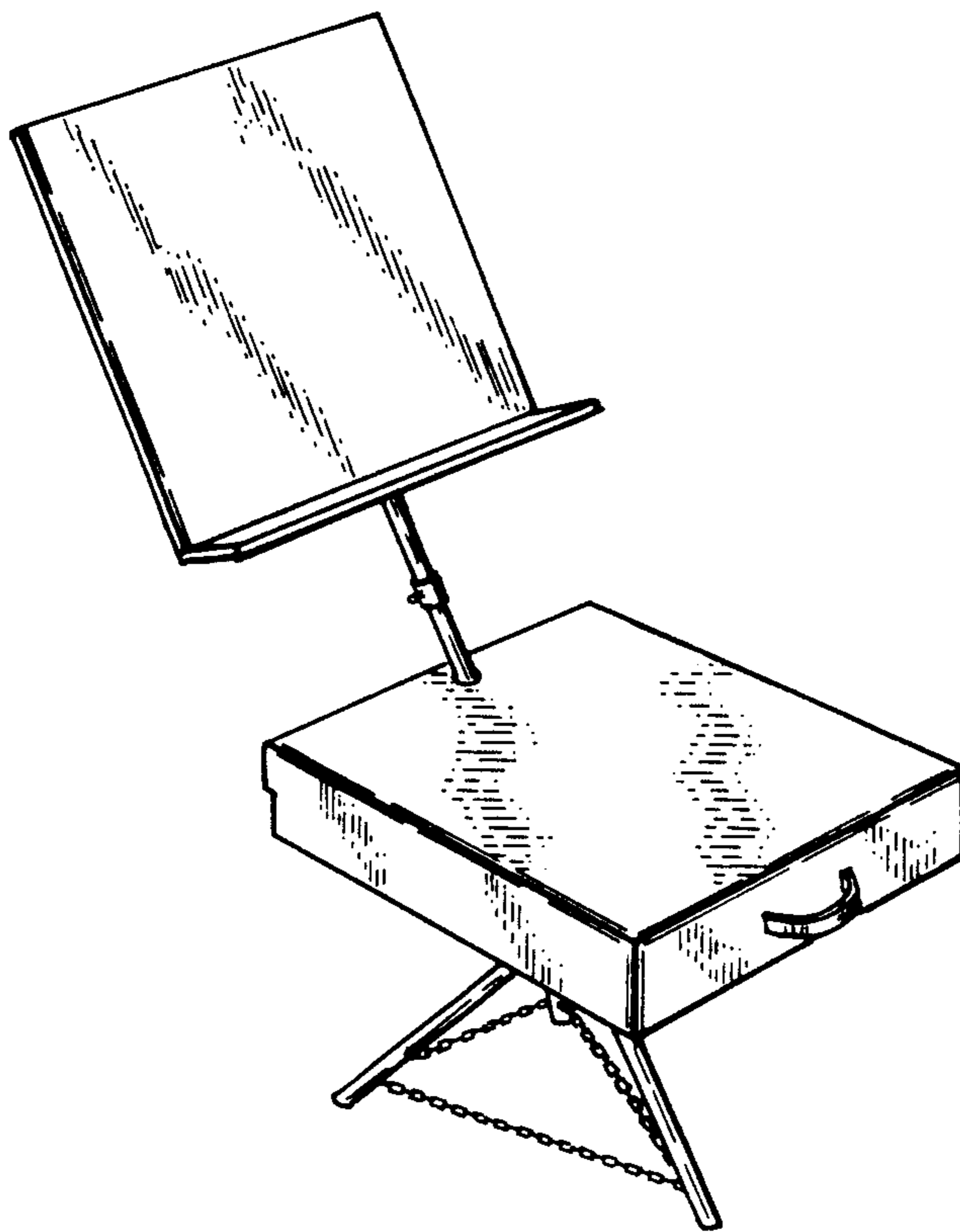

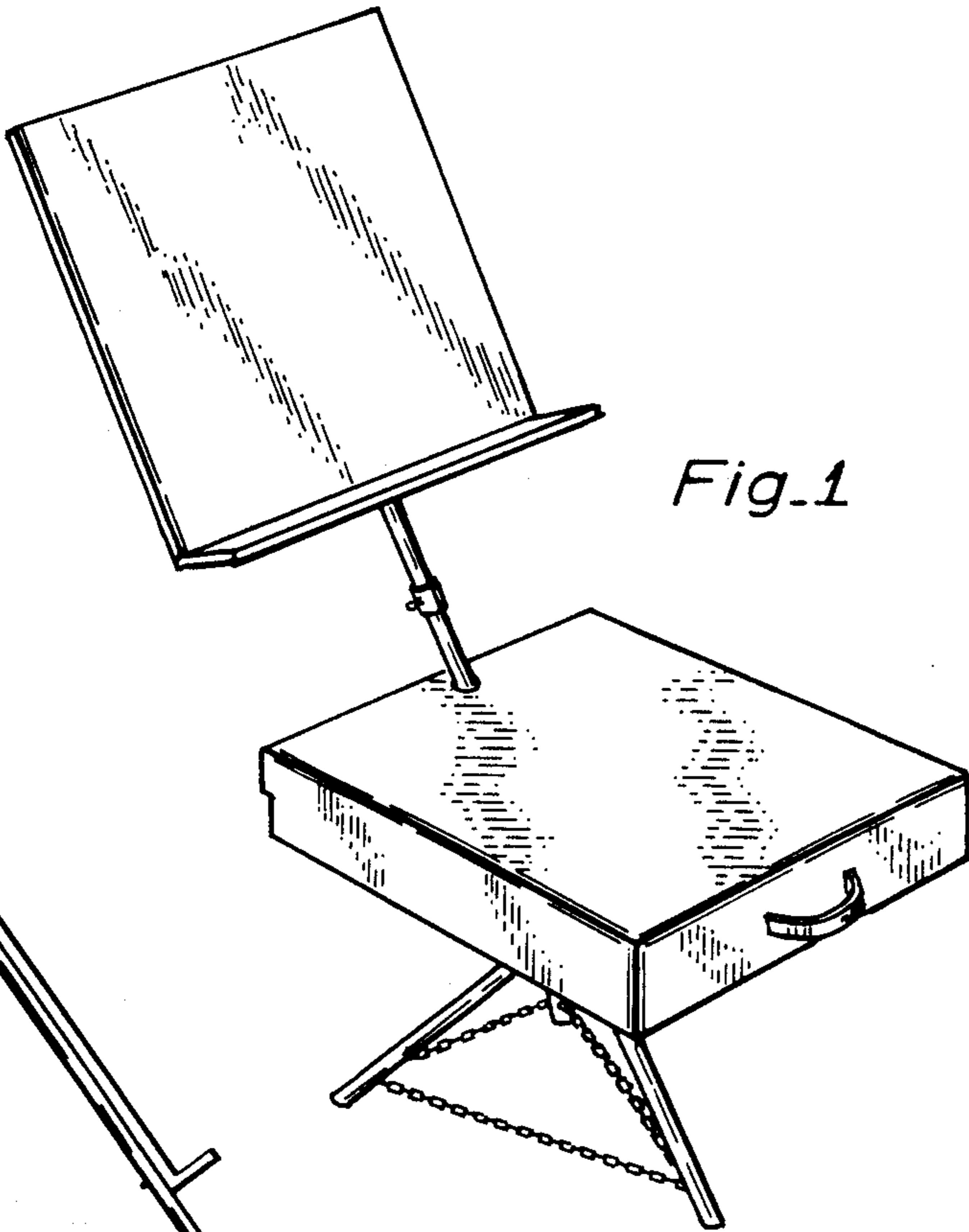

Fig. 1

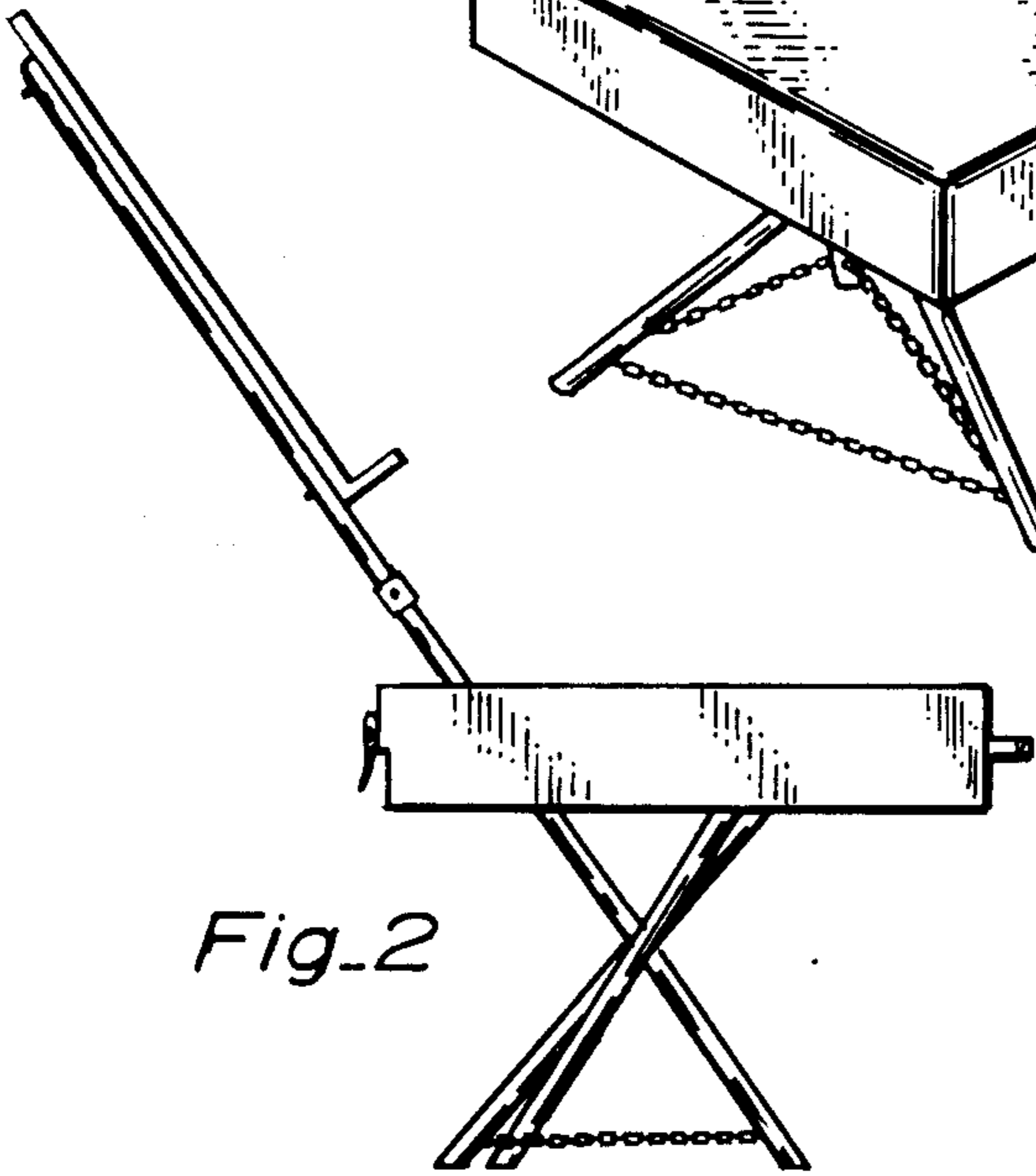

Fig. 2

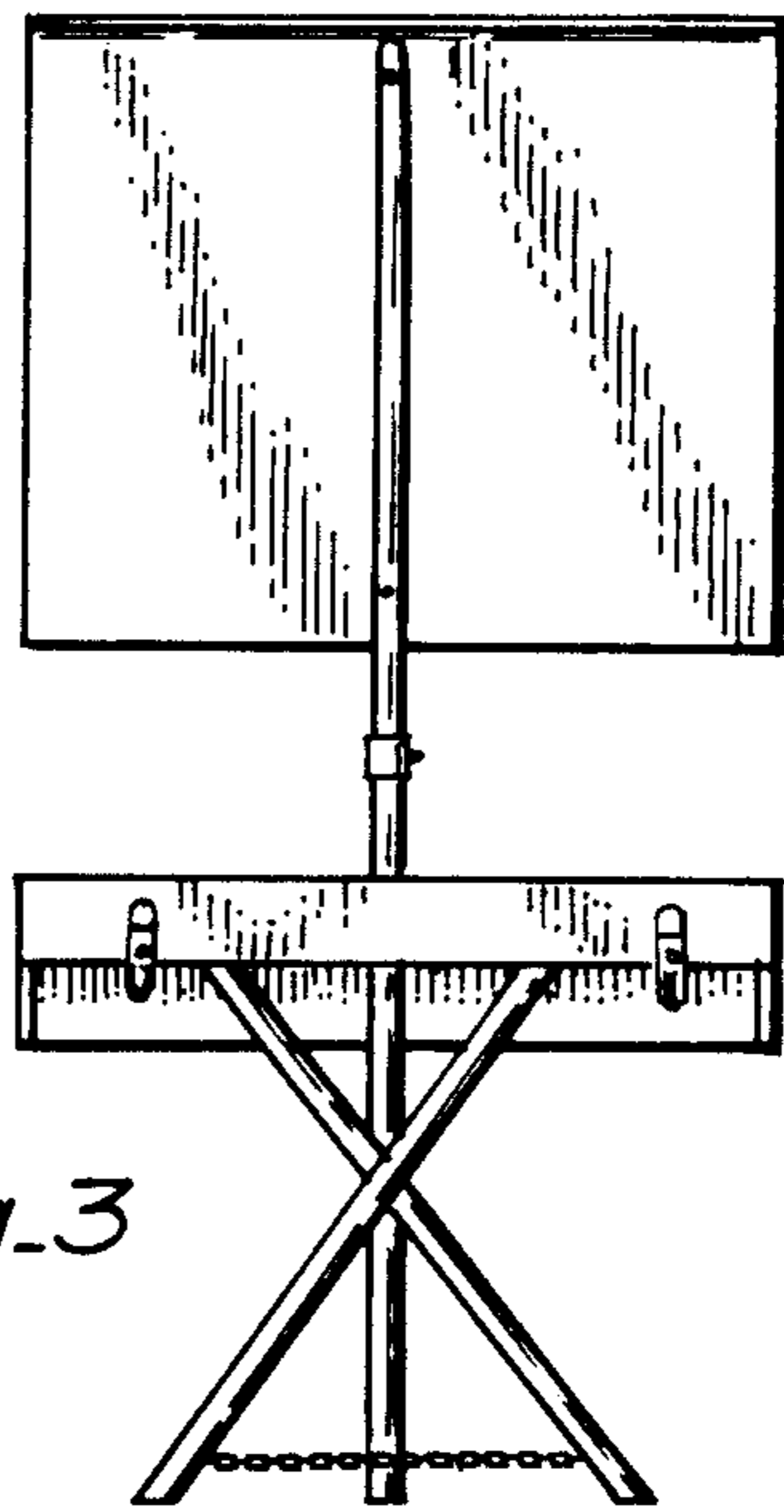

Fig. 3

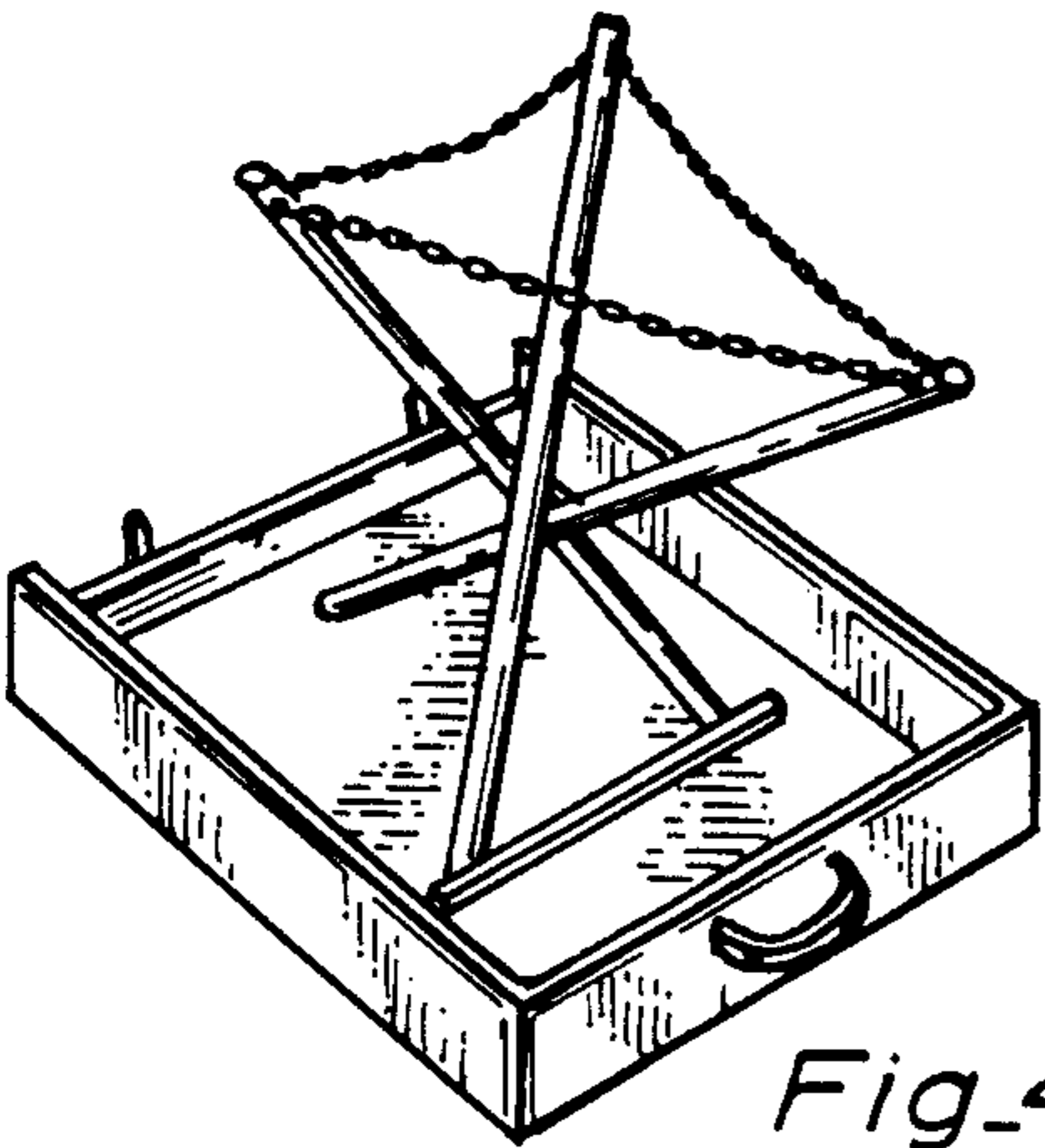

Fig. 4

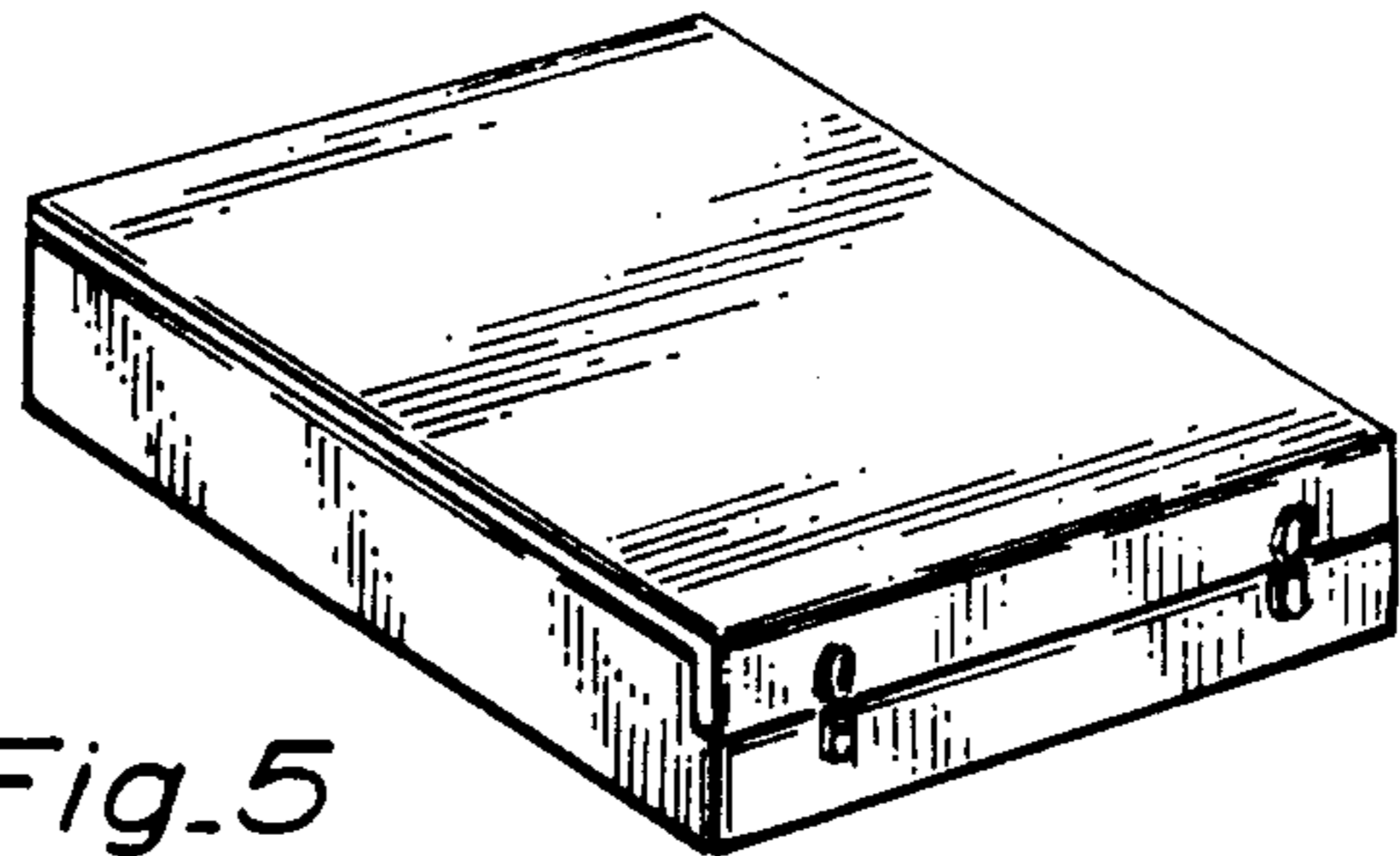

Fig. 5