

[54] TOY AIRPLANE

[76] Inventor: Sheldon N. Spizz, 41 Gage Ct., Freehold, N.J. 07728

[**] Term: 14 Years

[21] Appl. No.: 9,414

[22] Filed: Feb. 5, 1979

[51] Int. Cl. D21-01

[52] U.S. Cl. D21/89

[58] Field of Search D21/82, 87, 88, 89, D21/91, 49; 244/153 R, 153 A, 154, 155; 46/74 R, 74 D, 79, 80, 81

[56] References Cited

U.S. PATENT DOCUMENTS

D. 59,419	10/1921	Haworth	D21/89
D. 223,770	6/1972	Goodman	D21/89
1,790,849	2/1931	Tegarty	46/79
2,008,997	7/1935	Theodore	46/79

Primary Examiner—Charles A. Rademaker
Attorney, Agent, or Firm—Brumbaugh, Graves,
Donohue & Raymond

[57] CLAIM

The ornamental design for a toy airplane, substantially as shown and described.

DESCRIPTION

FIG. 1 is a top plan view of a toy airplane showing my new design;
 FIG. 2 is a right side elevational view thereof, the side opposite being substantially a mirror image;
 FIG. 3 is a front elevational view thereof;
 FIG. 4 is a rear elevational view thereof in an inverted condition;
 FIG. 5 is a bottom plan view thereof;
 FIG. 6 is a front perspective view thereof;
 FIG. 7 is a right side elevational view thereof showing the wind member in an alternate position; and
 FIG. 8 is a front perspective view of the embodiment shown in FIG. 7.

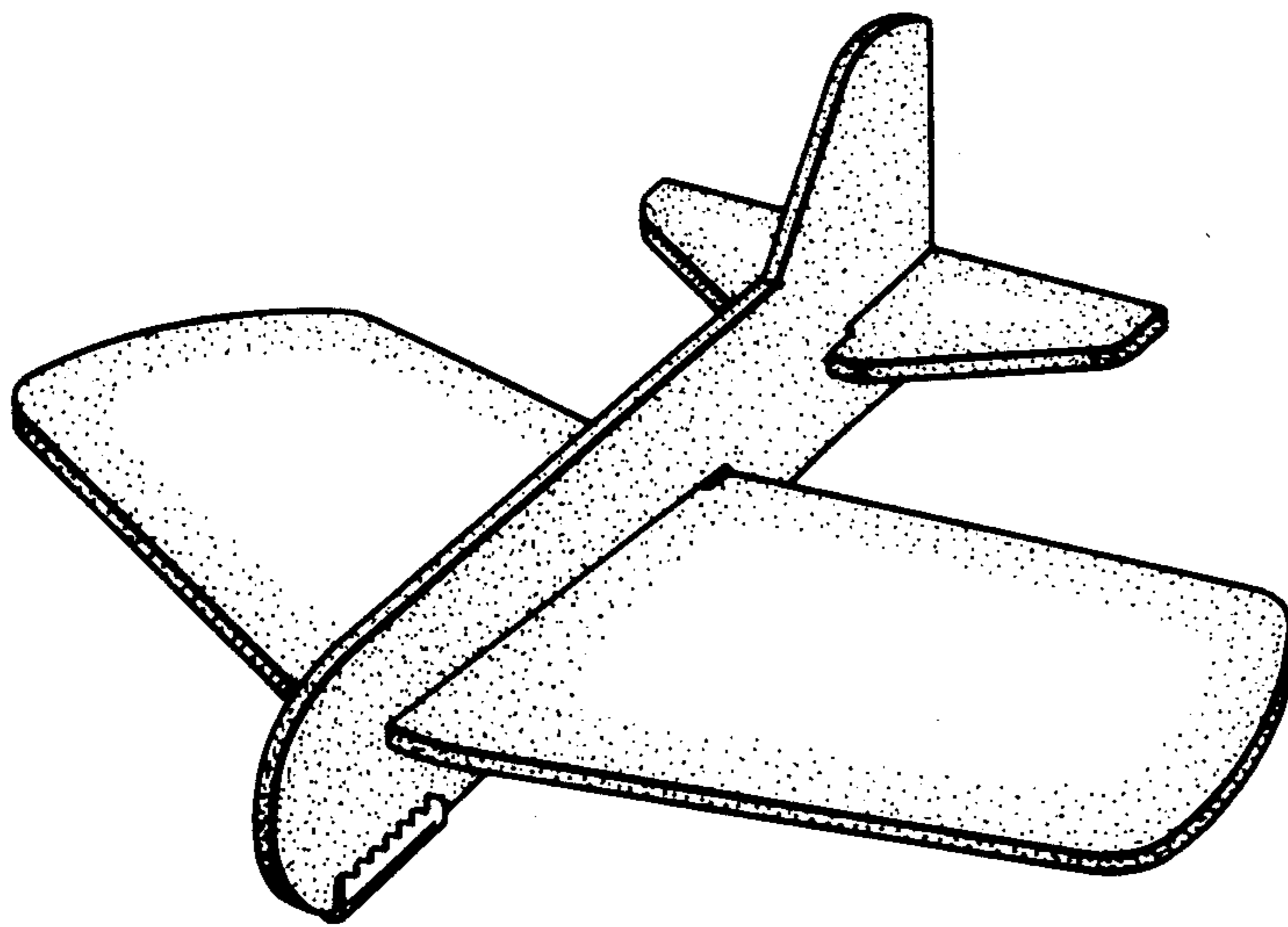

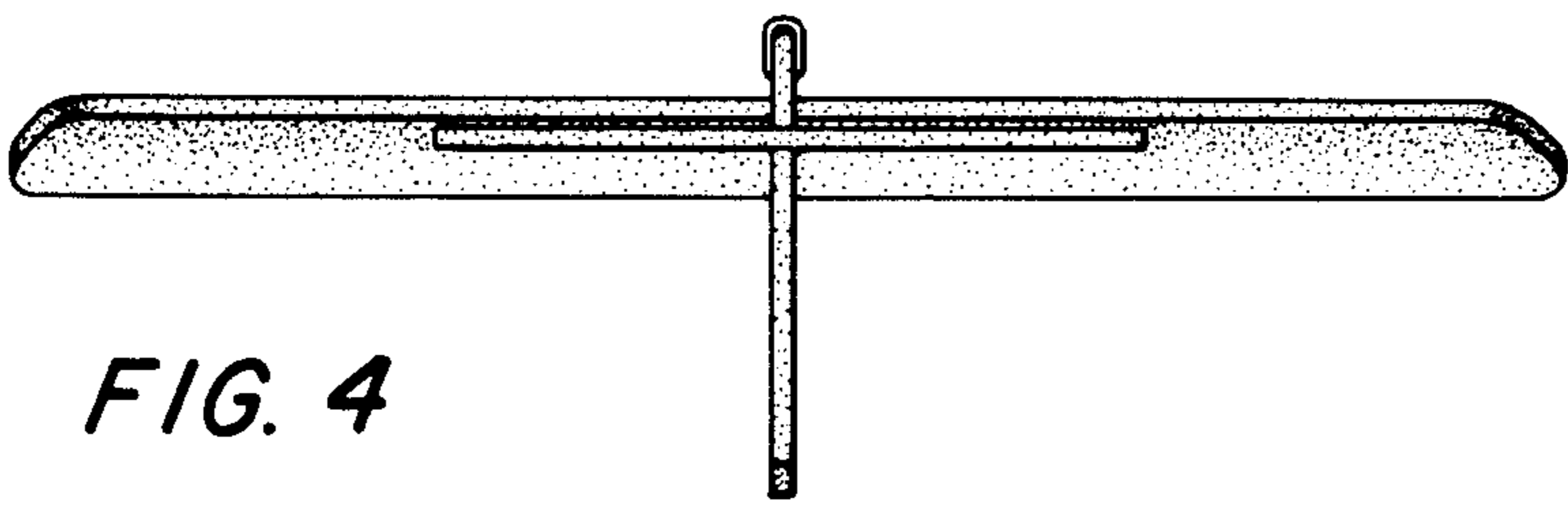

FIG. 4

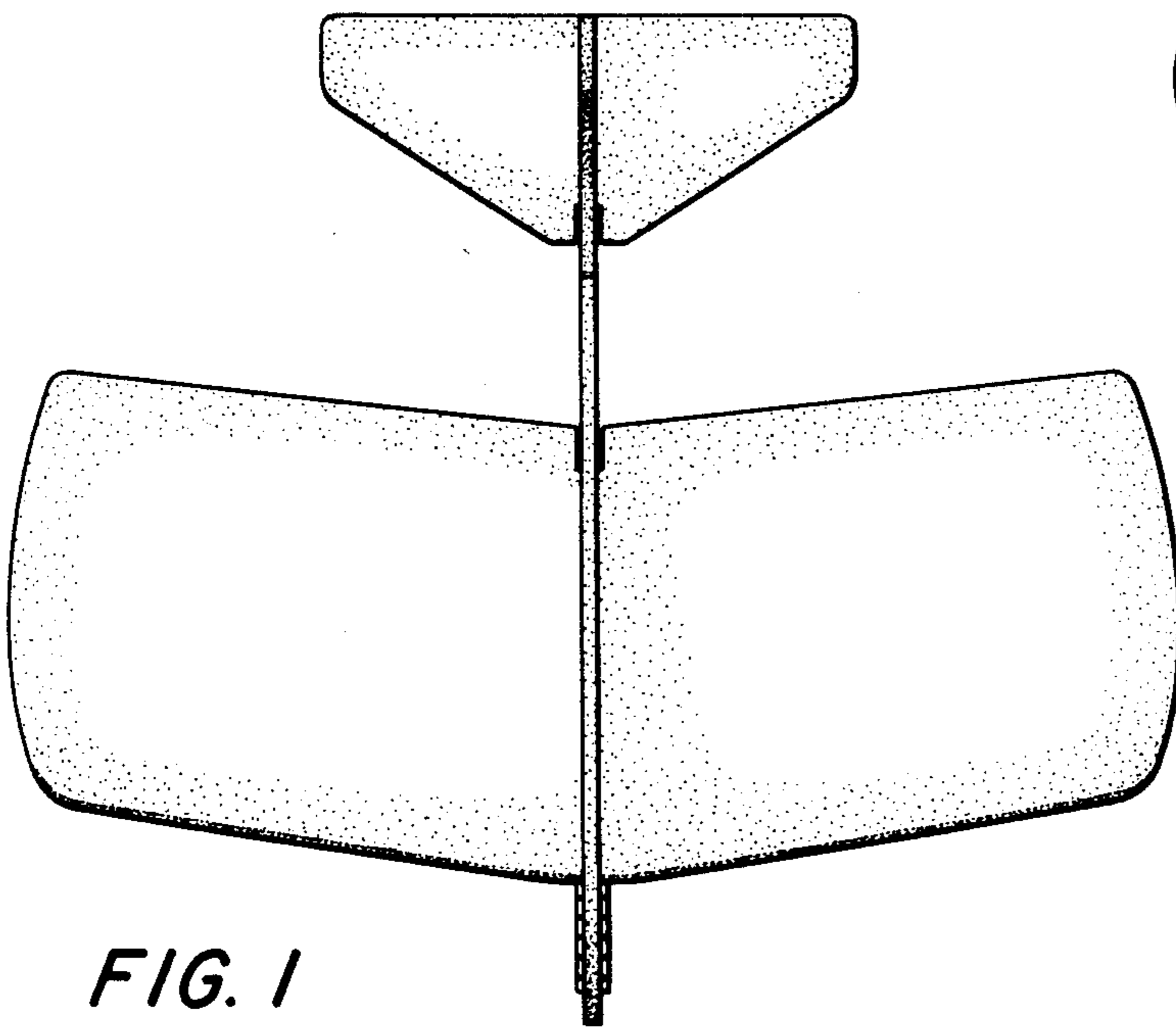

FIG. 1

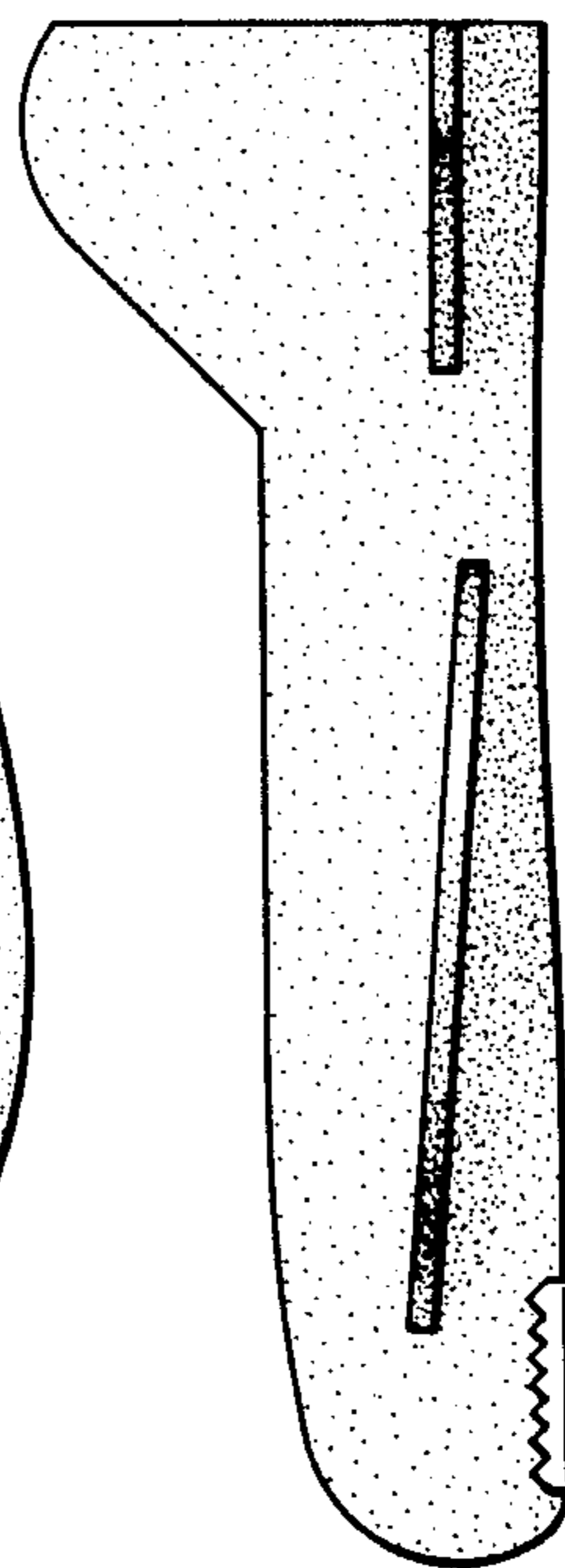

FIG. 2

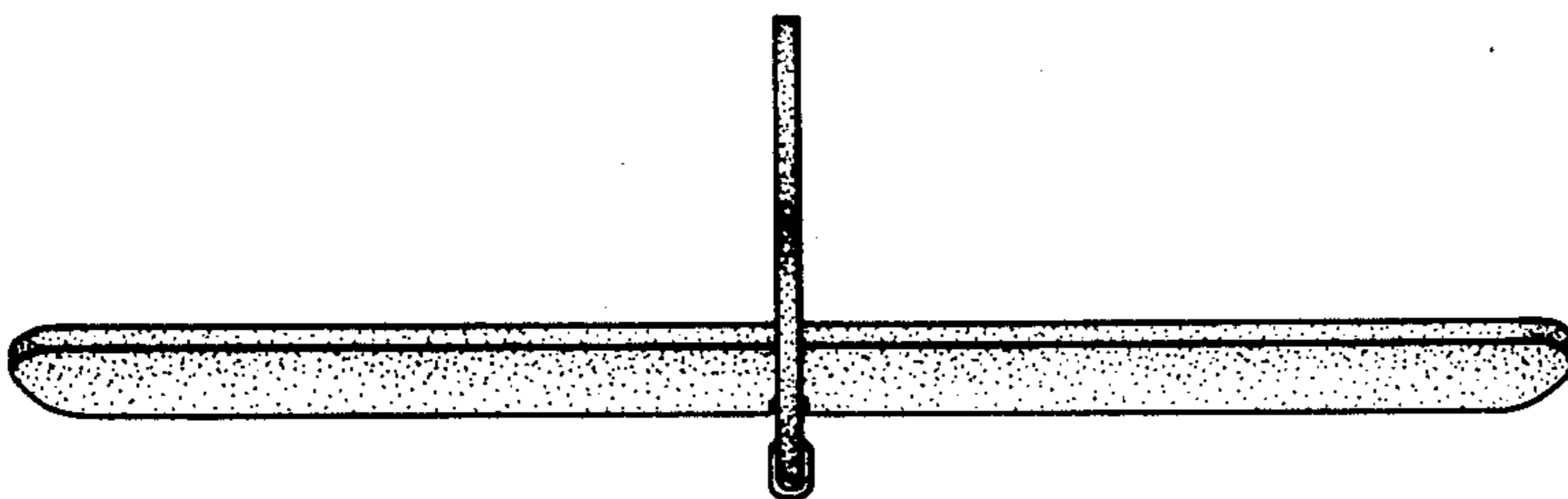

FIG. 3

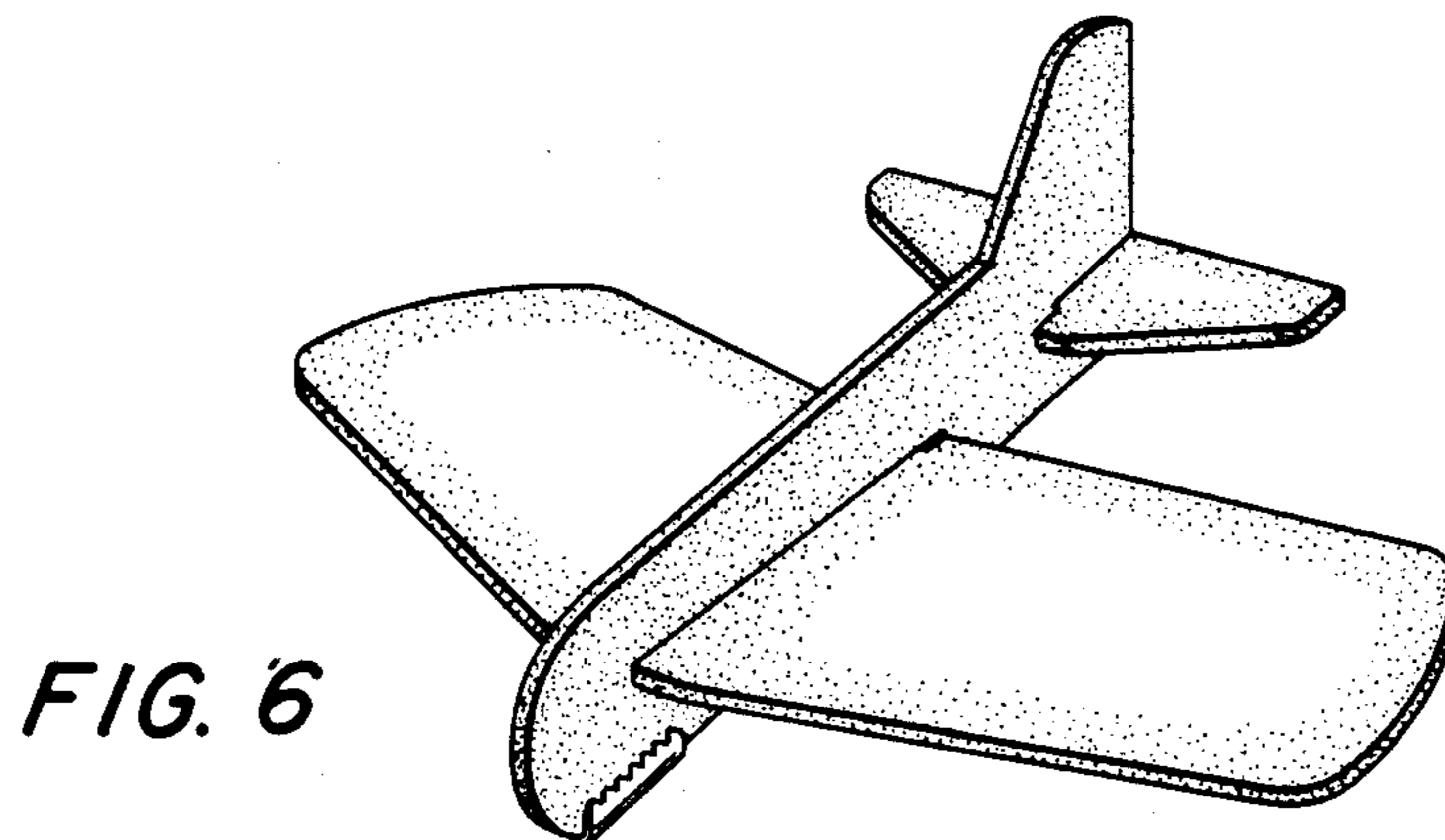

FIG. 6

