

[54] VEHICLE CAB

[75] Inventor: Peter Mende, Harsewinkel, Fed. Rep. of Germany

[73] Assignee: Gebr. Claas Maschinenfabrik GmbH, Harsewinkel, Fed. Rep. of Germany

[**] Term: 14 Years

[21] Appl. No.: 948,628

[22] Filed: Oct. 3, 1978

[51] Int. Cl. D15-03

[52] U.S. Cl. D15/30

[58] Field of Search D15/30; 296/190; 180/89.12

[56]

References Cited

U.S. PATENT DOCUMENTS

D. 253,057 10/1979 Fachini et al. D15/26

Primary Examiner—James M. Gandy
Attorney, Agent, or Firm—Michael J. Striker

[57]

CLAIM

The ornamental design for a vehicle cab, substantially as shown and described.

DESCRIPTION

FIG. 1 is a perspective view, showing the front and one side of a vehicle cab embodying my novel design;

FIG. 2 is an elevational view showing one side thereof;

FIG. 3 is an elevational view showing the other side thereof;

FIG. 4 is a front elevational view thereof;

FIG. 5 is a top plan view thereof; and

FIG. 6 is a rear elevational view thereof.

The bottom is plain and unornamented.

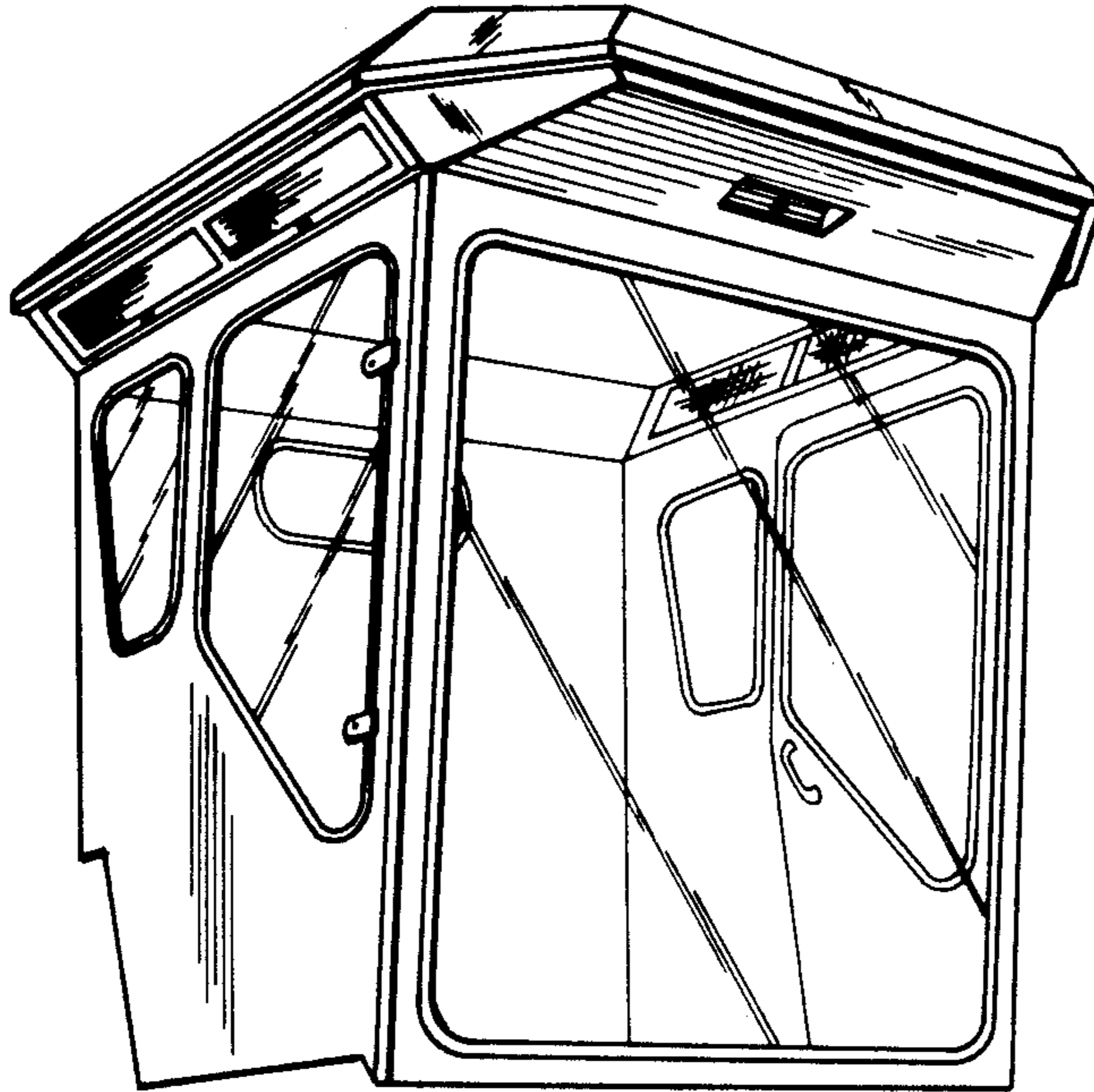

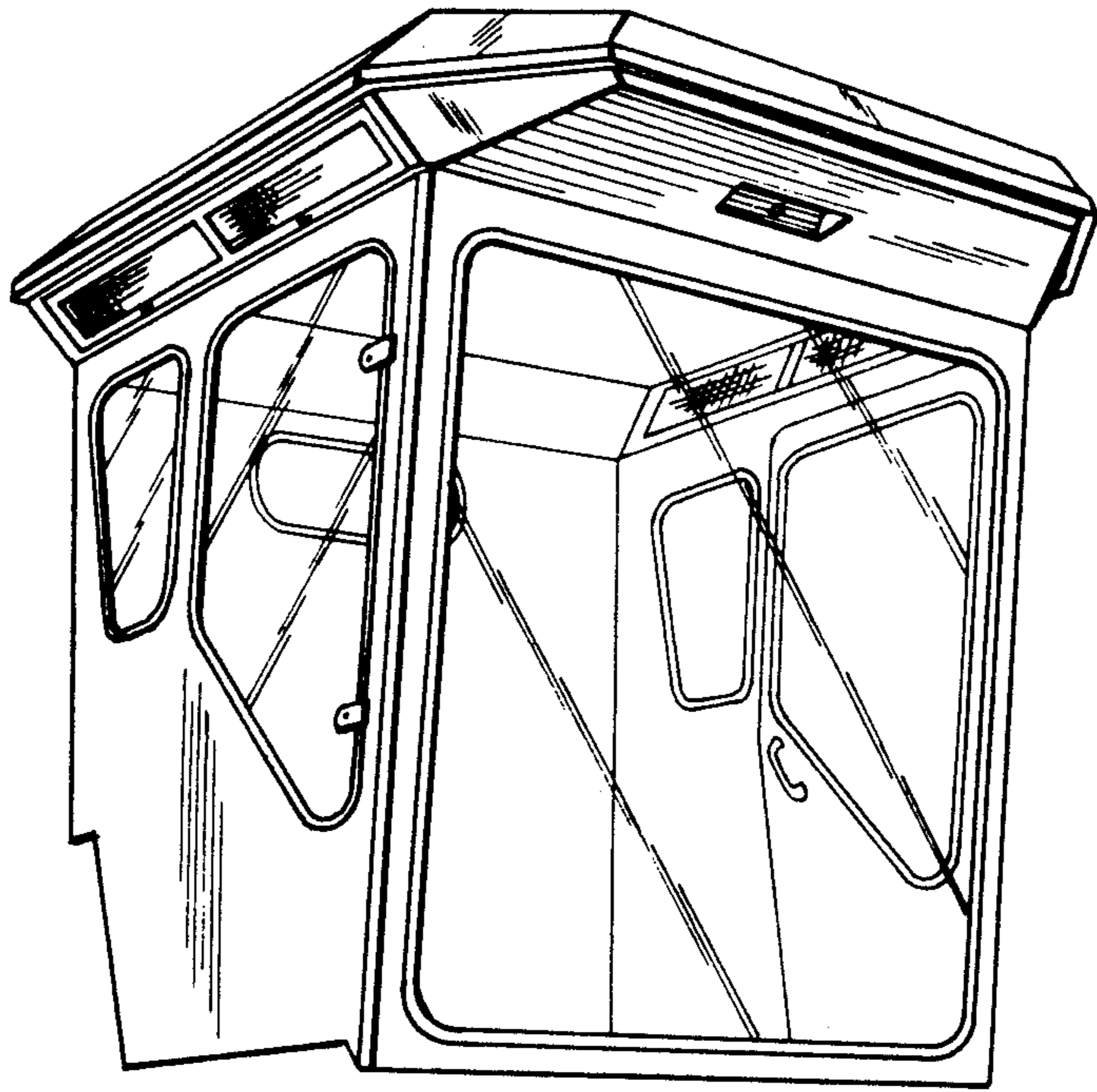

FIG. 1

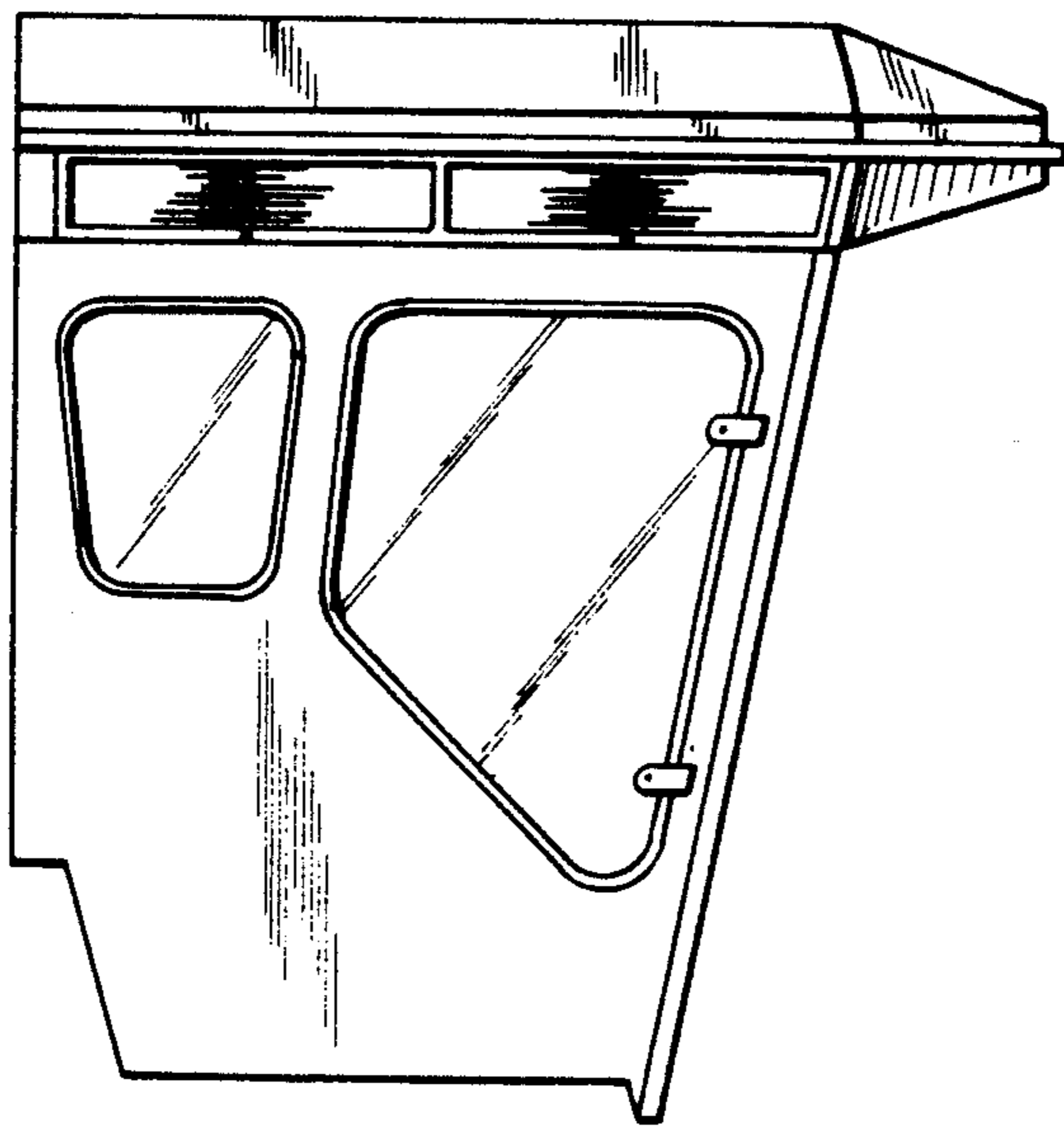

FIG. 2

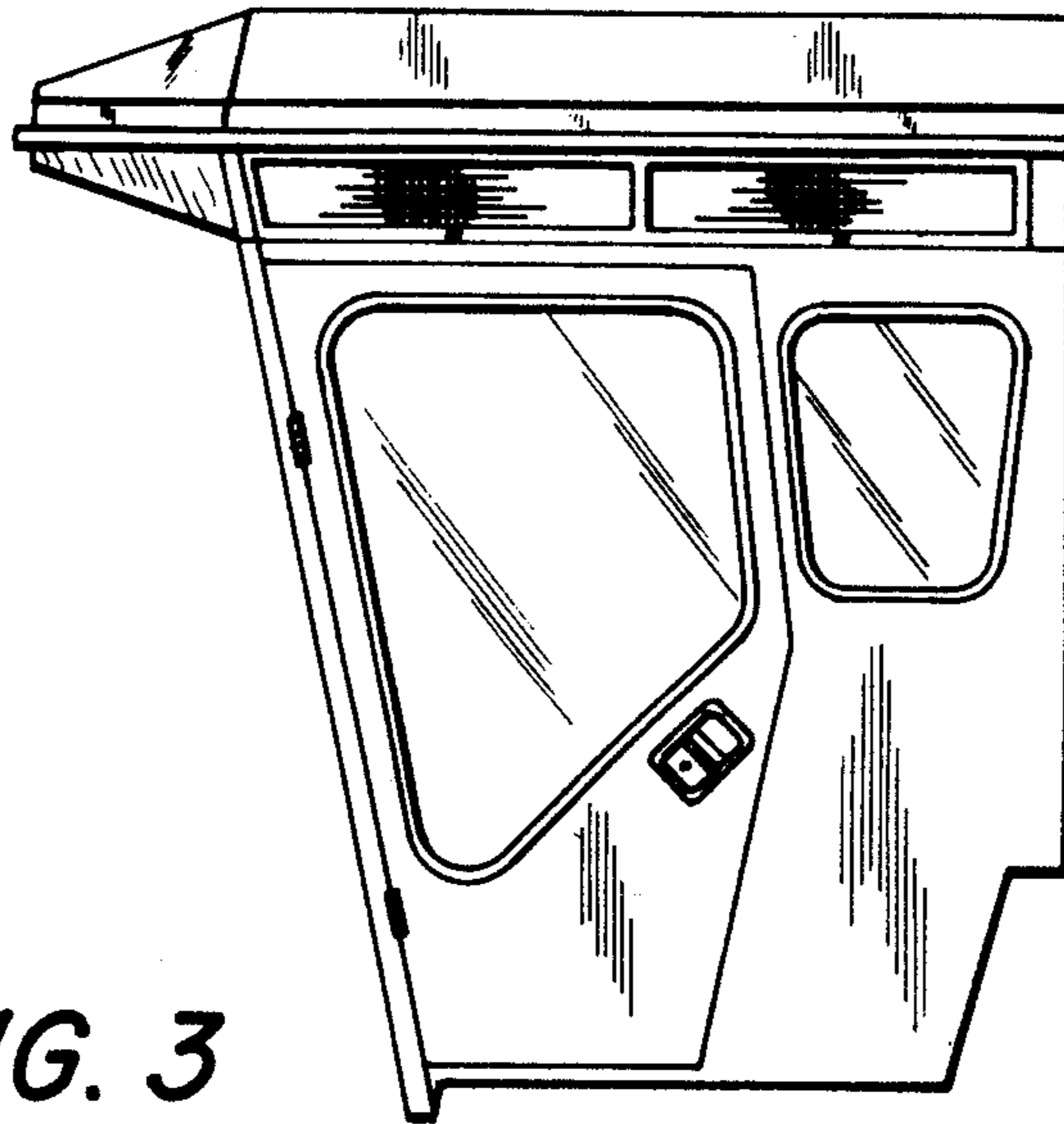

FIG. 3

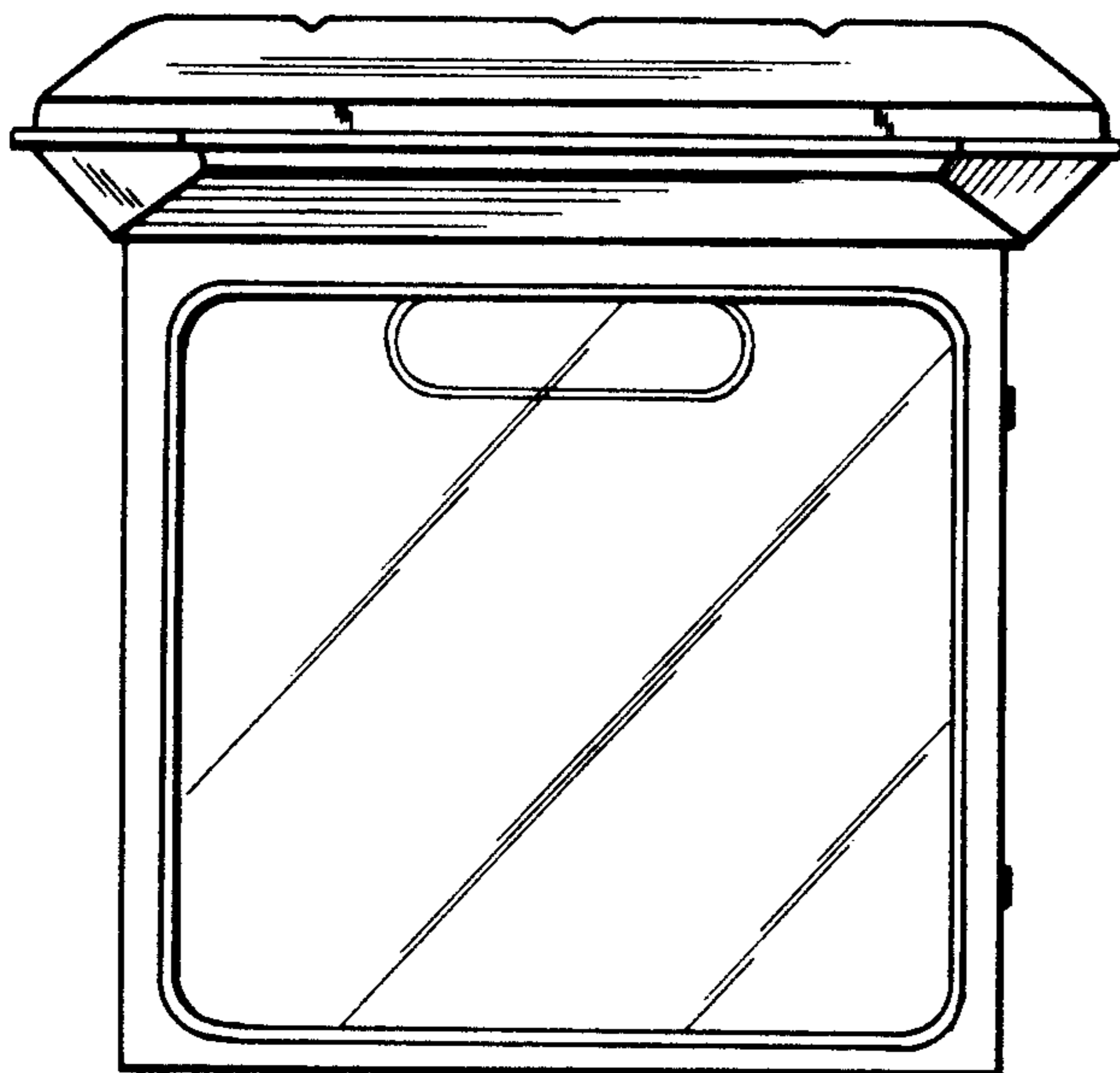

FIG. 4

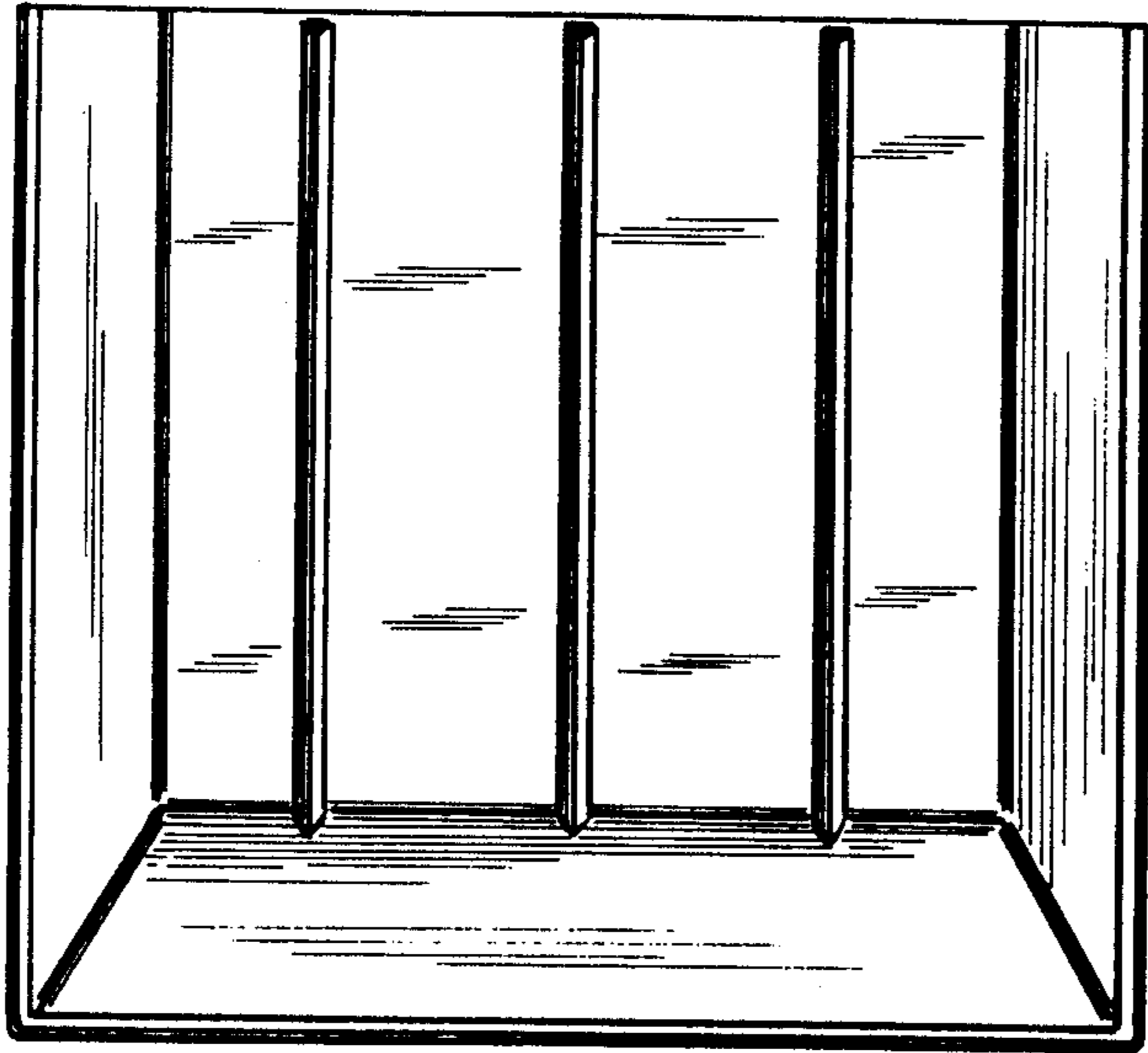

FIG. 5

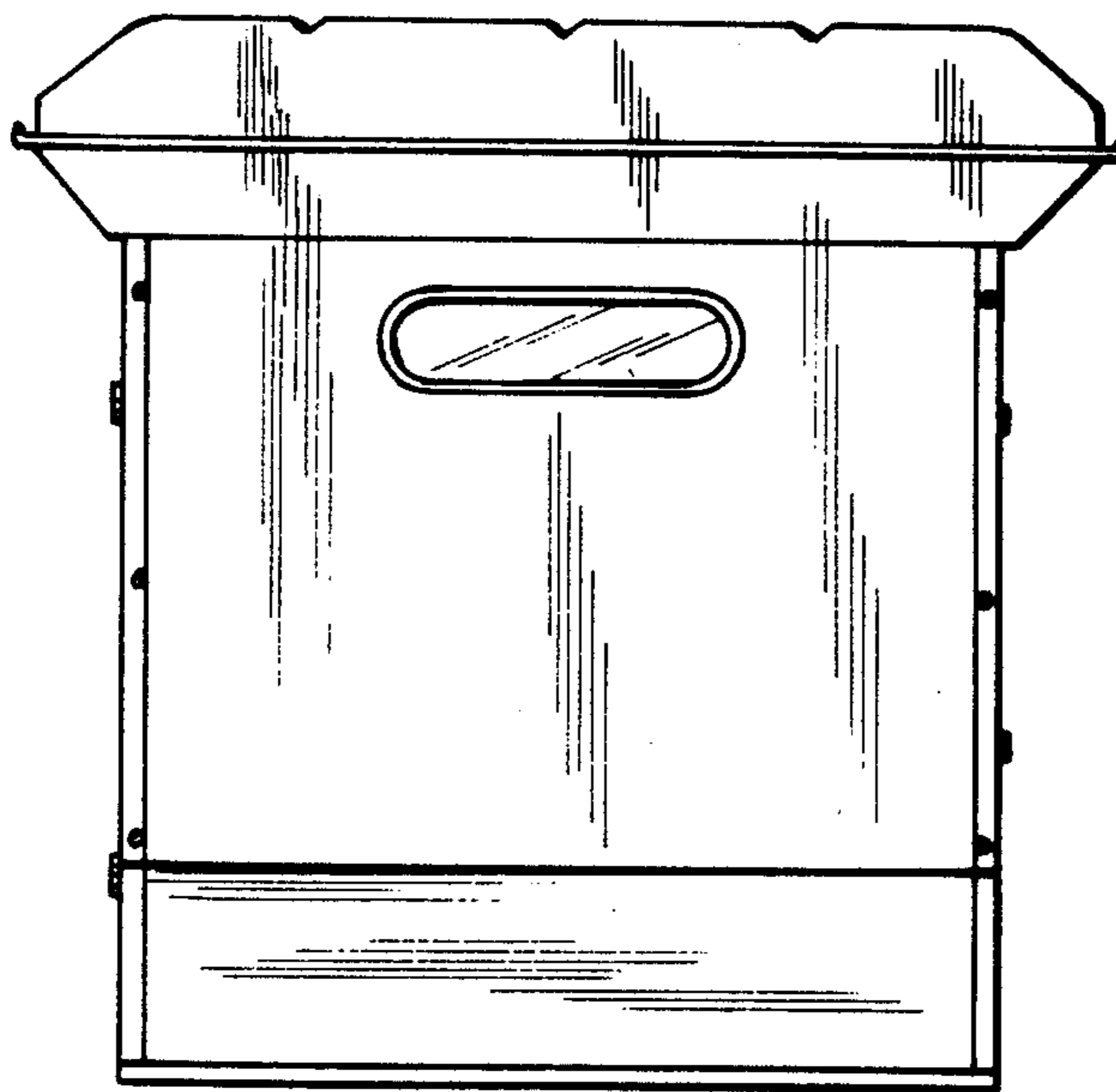

FIG. 6

UNITED STATES PATENT AND TRADEMARK OFFICE
CERTIFICATE OF CORRECTION

PATENT NO. : Des. 259045
DATED : April 28, 1981
INVENTOR(S) : Peter Mende

It is certified that error appears in the above—identified patent and that said Letters Patent is hereby corrected as shown below:

On the title page, Item [30] should read:

--- Germany MR 1000 May 31, 1978 ---.

Signed and Sealed this

Sixth Day of October 1981

[SEAL]

Attest:

GERALD J. MOSSINGHOFF

Attesting Officer

Commissioner of Patents and Trademarks