

[54] WHEEL FOR AUTOMOBILES

[75] Inventor: Masakazu Hayashi, Higashi-Osaka, Japan

[73] Assignee: Kabushiki Kaisha Hayashi Racing, Osaka, Japan

[\*\*] Term: 14 Years

[21] Appl. No.: 920,245

[22] Filed: Jun. 29, 1978

[30] Foreign Application Priority Data

Dec. 29, 1977 [JP] Japan ..... 52-52352

[51] Int. Cl. .... D12-16

[52] U.S. Cl. .... D12/211

[58] Field of Search ..... D12/209-211, D12/205; 301/63 R, 63 DD, 63 DT, 63 PW, 64 R, 64 SH, 64 S, 65, 66

[56] References Cited

U.S. PATENT DOCUMENTS

D. 53,543 7/1919 West ..... D12/205

D. 247,808 5/1978 Woodward ..... D12/211

FOREIGN PATENT DOCUMENTS

1236353 6/1971 United Kingdom ..... 301/65

OTHER PUBLICATIONS

Modern Tire Dealer, 2/77, p. 17, Wheel, top left side of page.

Primary Examiner—James M. Gandy

Attorney, Agent, or Firm—James E. Armstrong, III

[57] CLAIM

The ornamental design for a wheel for automobiles, as shown and described.

DESCRIPTION

FIG. 1 is a front perspective view of a wheel for automobiles showing my new design.

FIG. 2 is a rear perspective view thereof.

FIG. 3 is an enlarged cross sectional view thereof taken along line III—III in FIG. 1; and

FIG. 4 is a greatly enlarged cross sectional view thereof taken along line IV—IV in FIG. 1.

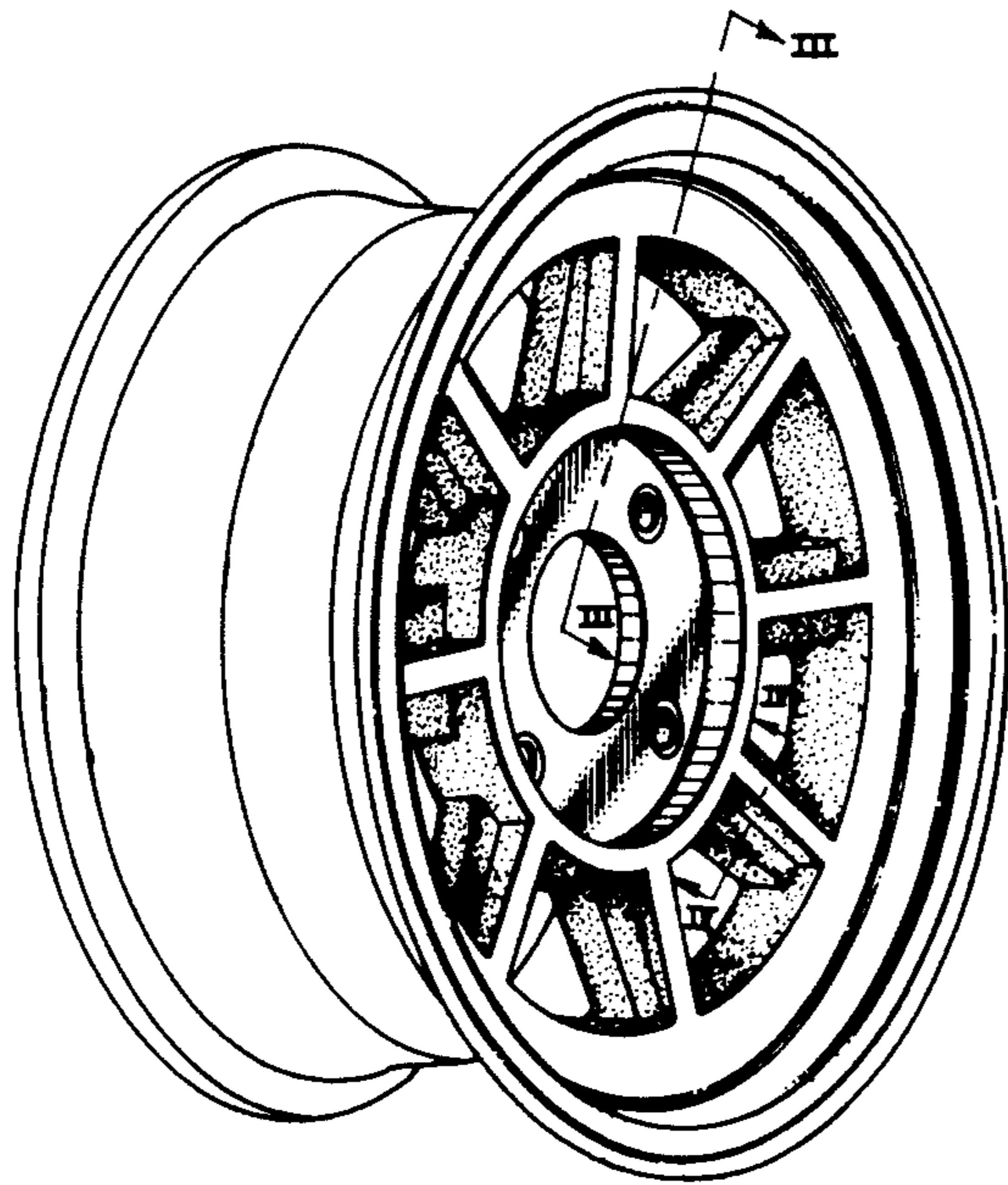

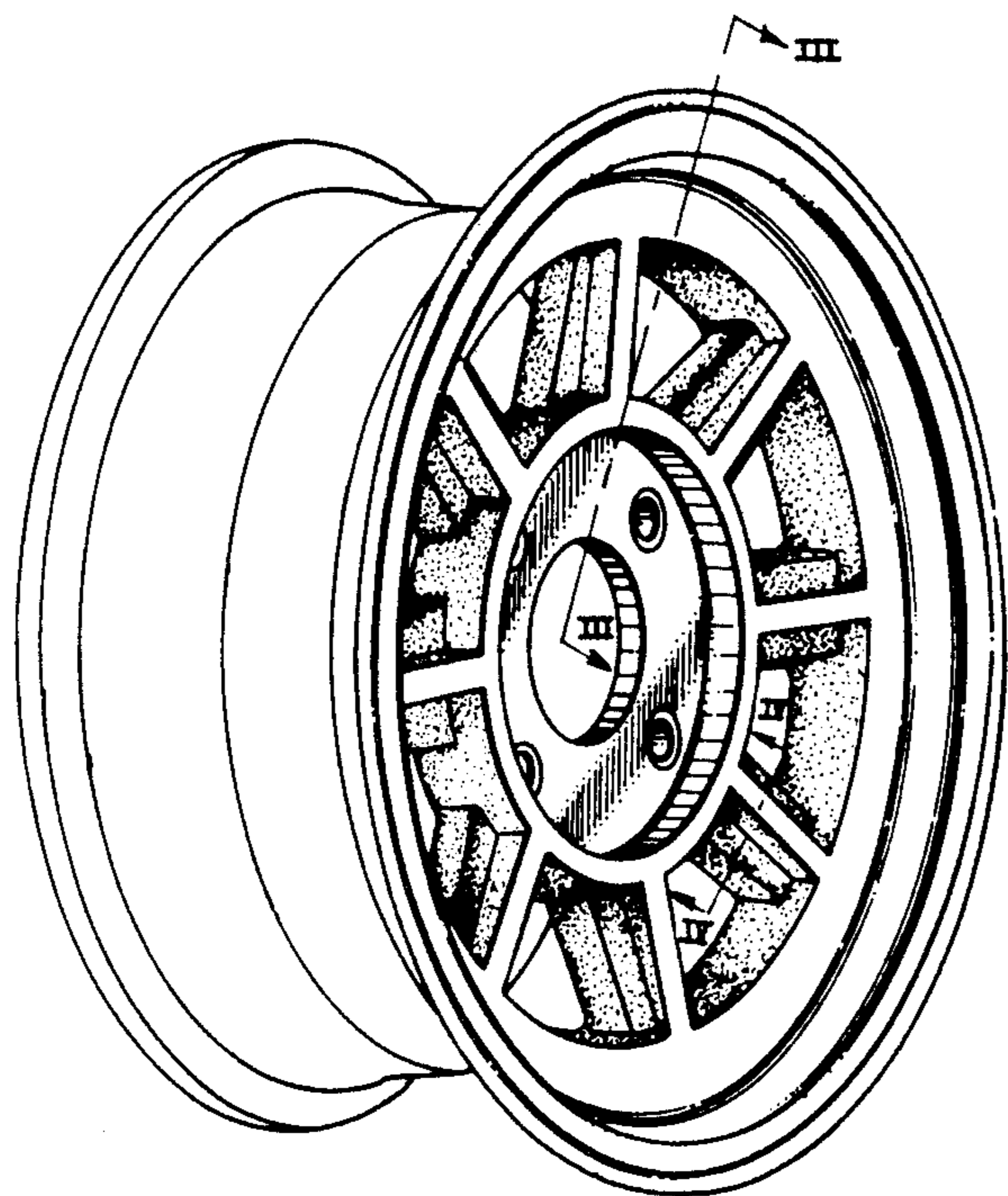

FIG. 1

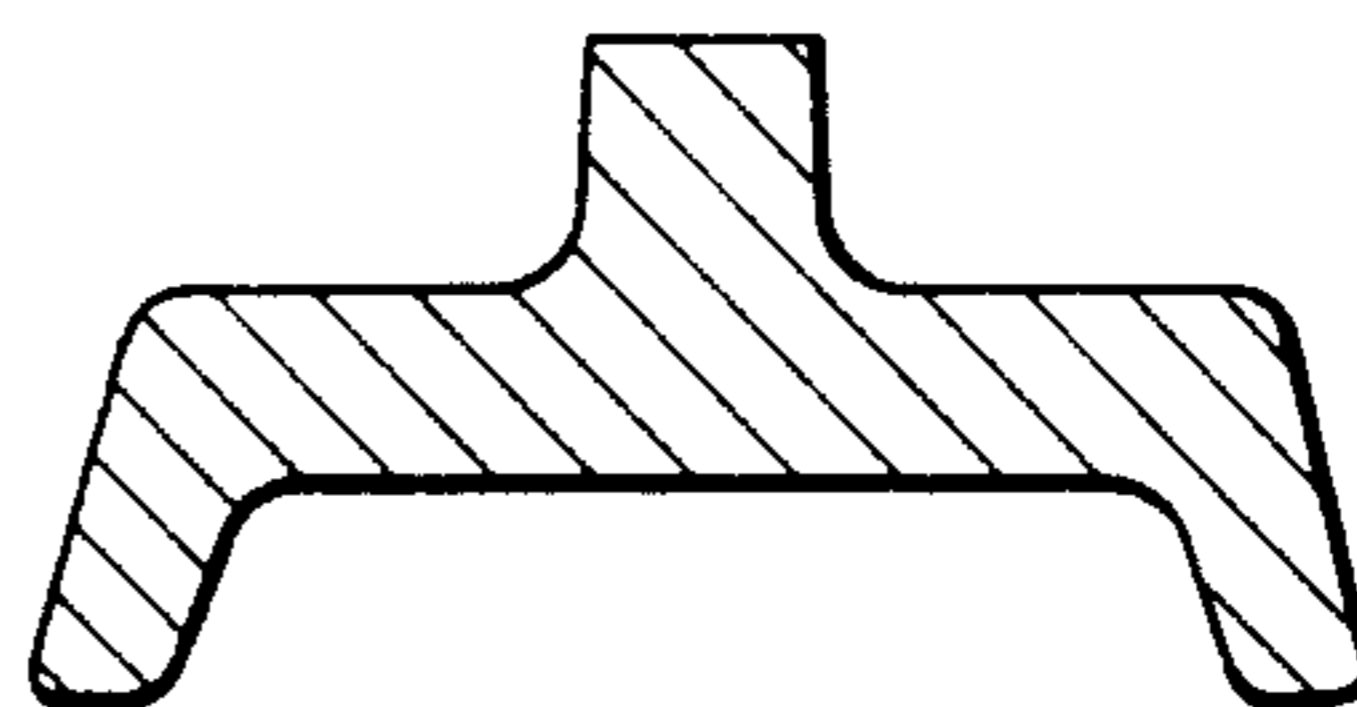

FIG. 4

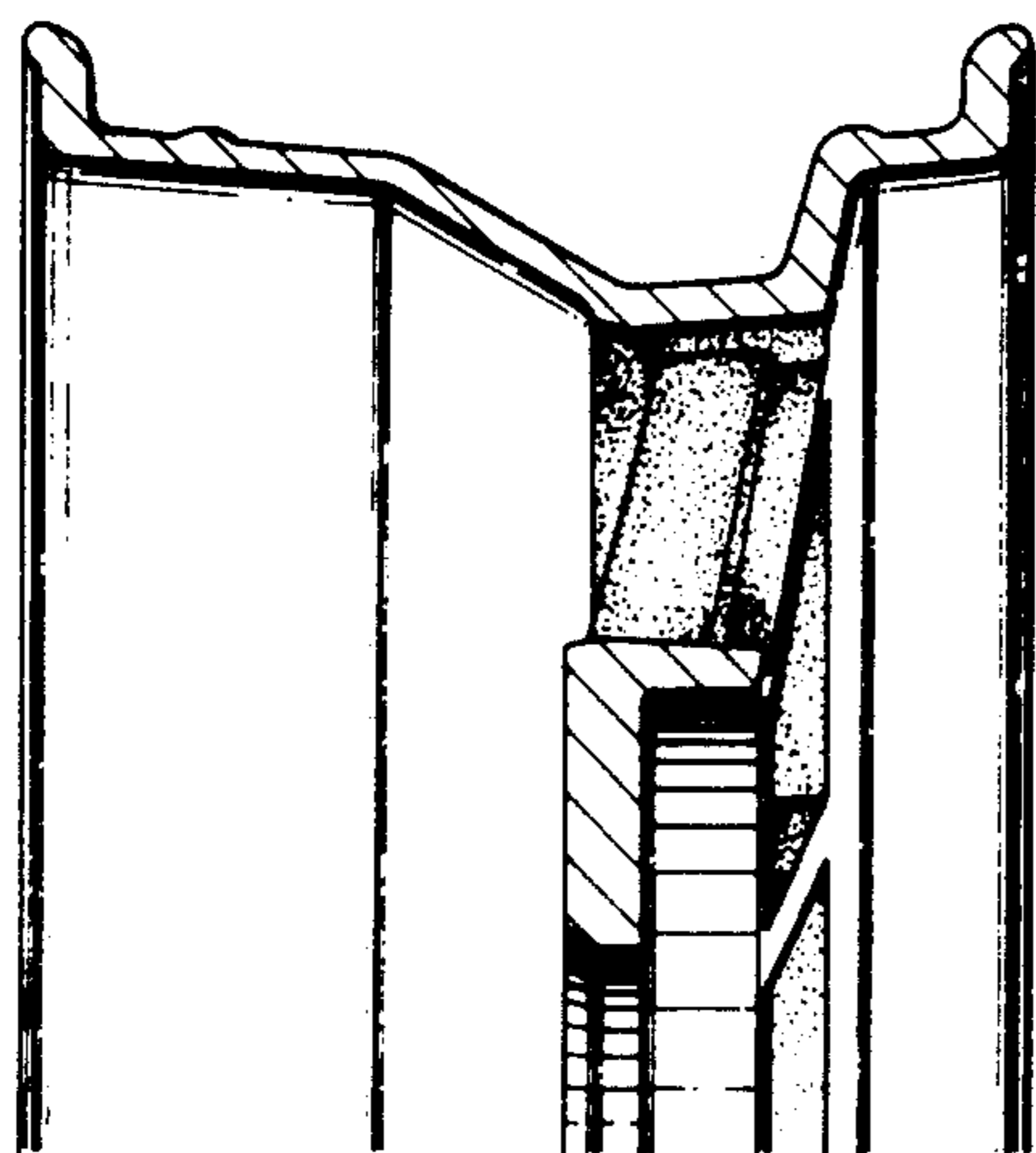
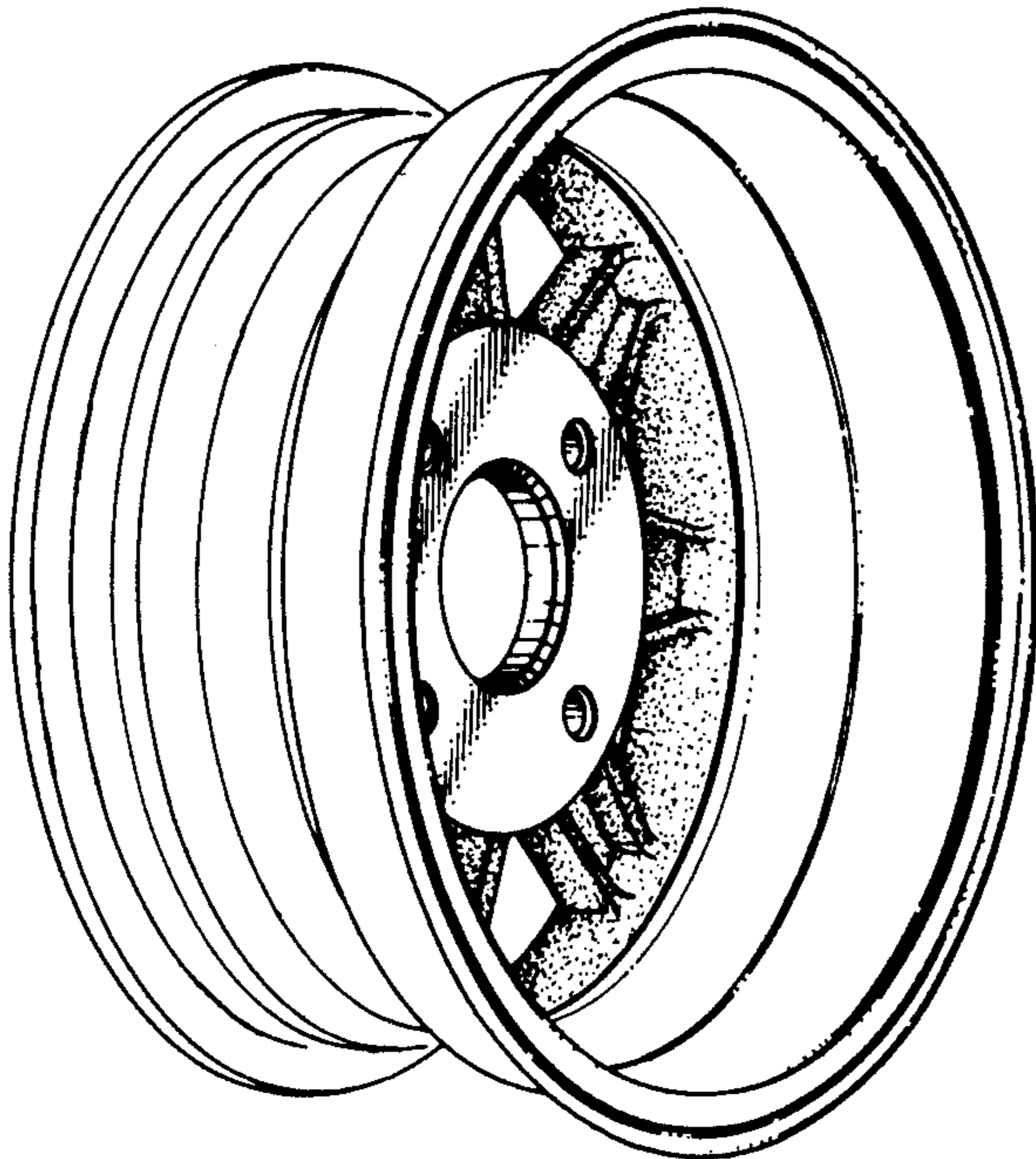

FIG. 3



*FIG. 2*