

[54] VEHICLE LIGHT

[75] Inventor: Robert M. Levy, Delran, N.J.

[73] Assignee: Arrow Safety Device Company, Mount Holly, N.J.

[**] Term: 14 Years

[21] Appl. No.: 948,765

[22] Filed: Oct. 3, 1978

[51] Int. Cl. D26-06

[52] U.S. Cl. D26/35

[58] Field of Search D26/28, 29, 31, 34, D26/35, 36; 362/61, 64, 235, 257, 268, 269, 362, 374, 375

[56] References Cited

U.S. PATENT DOCUMENTS

D. 62,945 8/1923 Godley D26/35
D. 237,648 11/1975 Cibie D26/28

OTHER PUBLICATIONS

Arrow Sealed Beam Mini-Catalog, p. 2, Snow-plow Headlamp/turn signal.

Primary Examiner—Susan J. Lucas
Attorney, Agent, or Firm—George A. Smith, Jr.

[57] CLAIM

The ornamental design for a vehicle light, as shown and described.

DESCRIPTION

FIG. 1 is an oblique perspective view of the vehicle light showing my new design;

FIG. 2 is a top plan view thereof on a reduced scale;

FIG. 3 is a front elevation thereof on a reduced scale and;

FIG. 4 is a bottom plan view thereof on a reduced scale;

FIG. 5 is a right-hand side elevation thereof on a reduced scale;

FIG. 6 is a left-hand side elevation thereof on a reduced scale; and

FIG. 7 is a rear elevation thereof on a reduced scale.

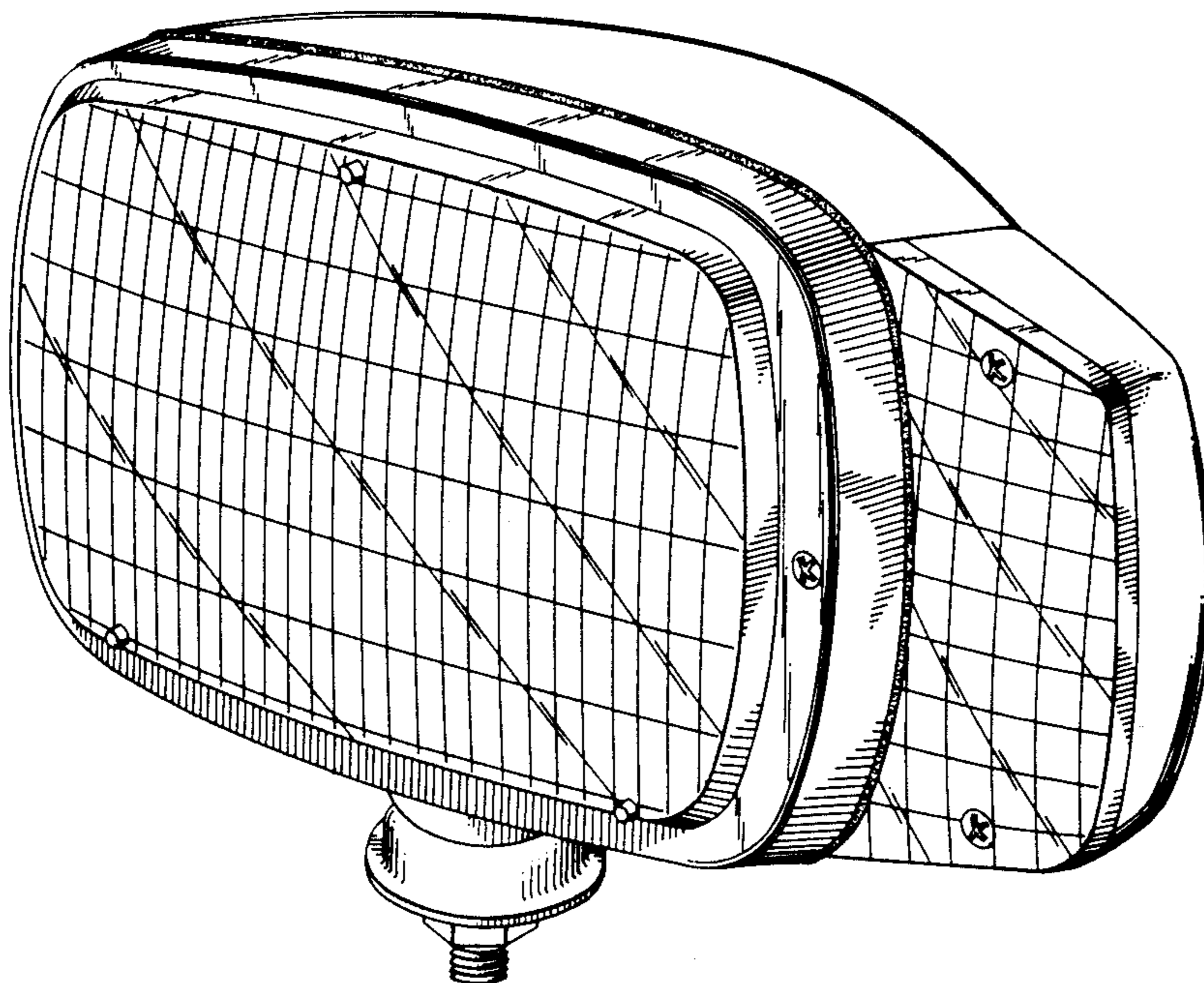
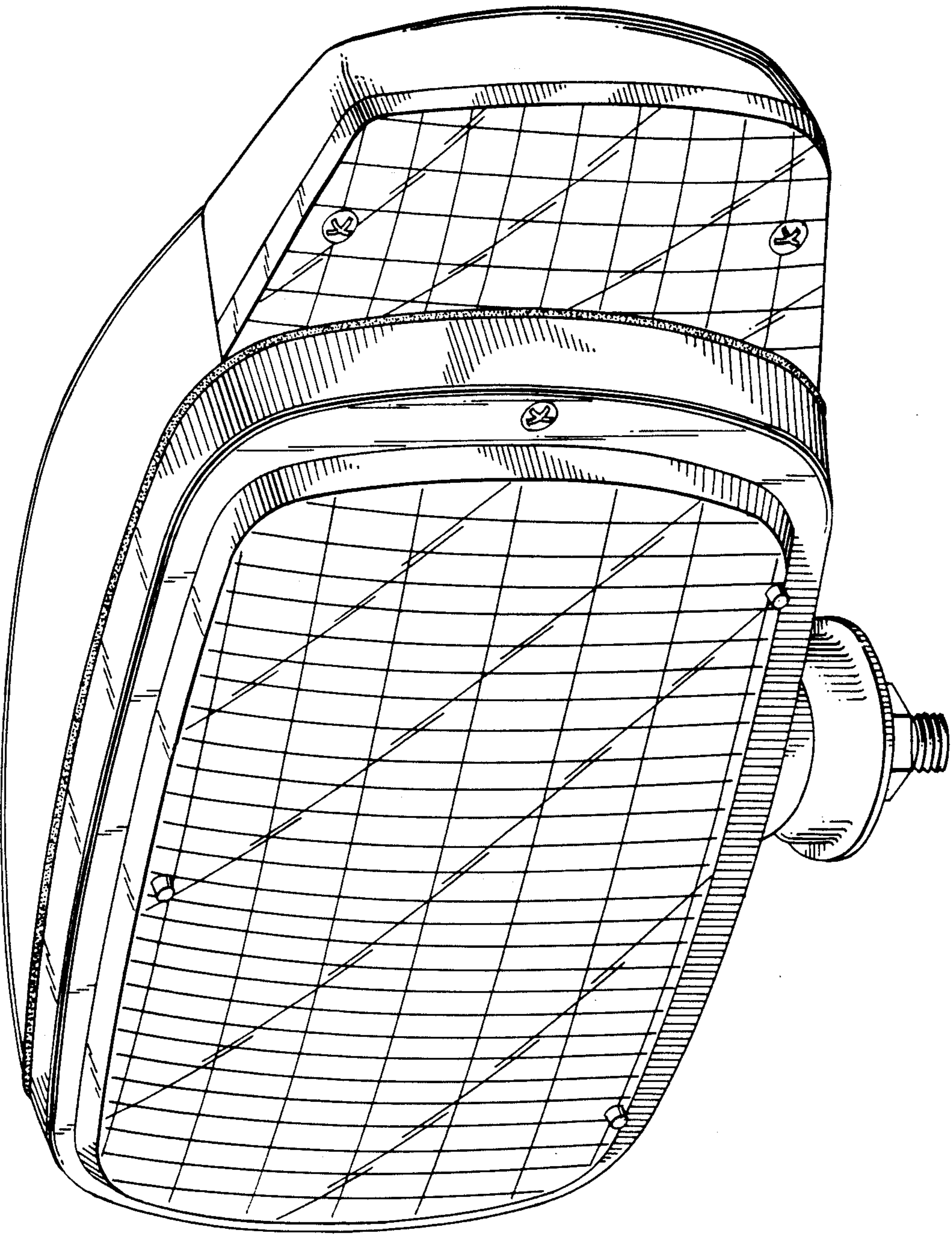

FIG. 1.



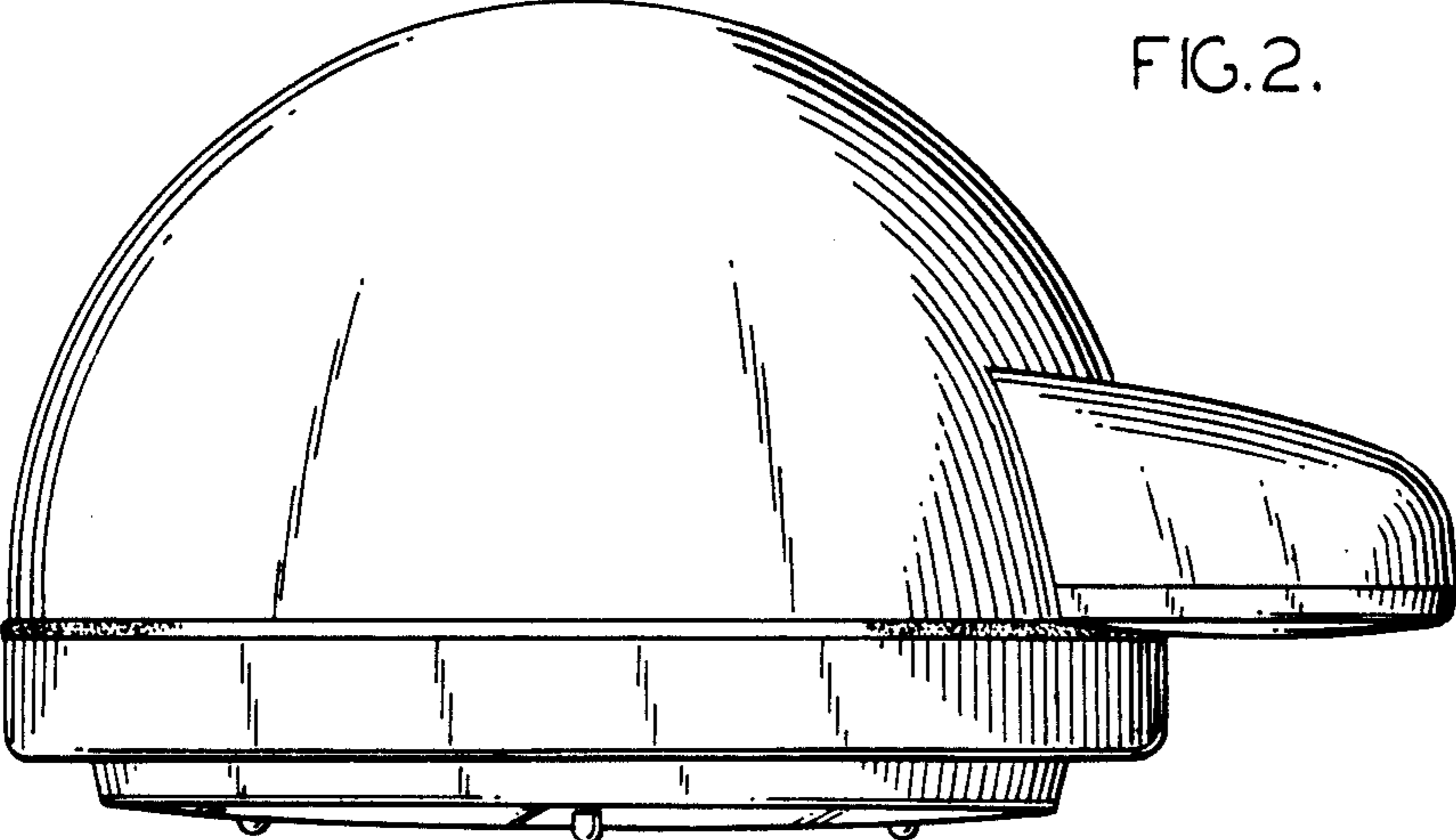

FIG. 2.

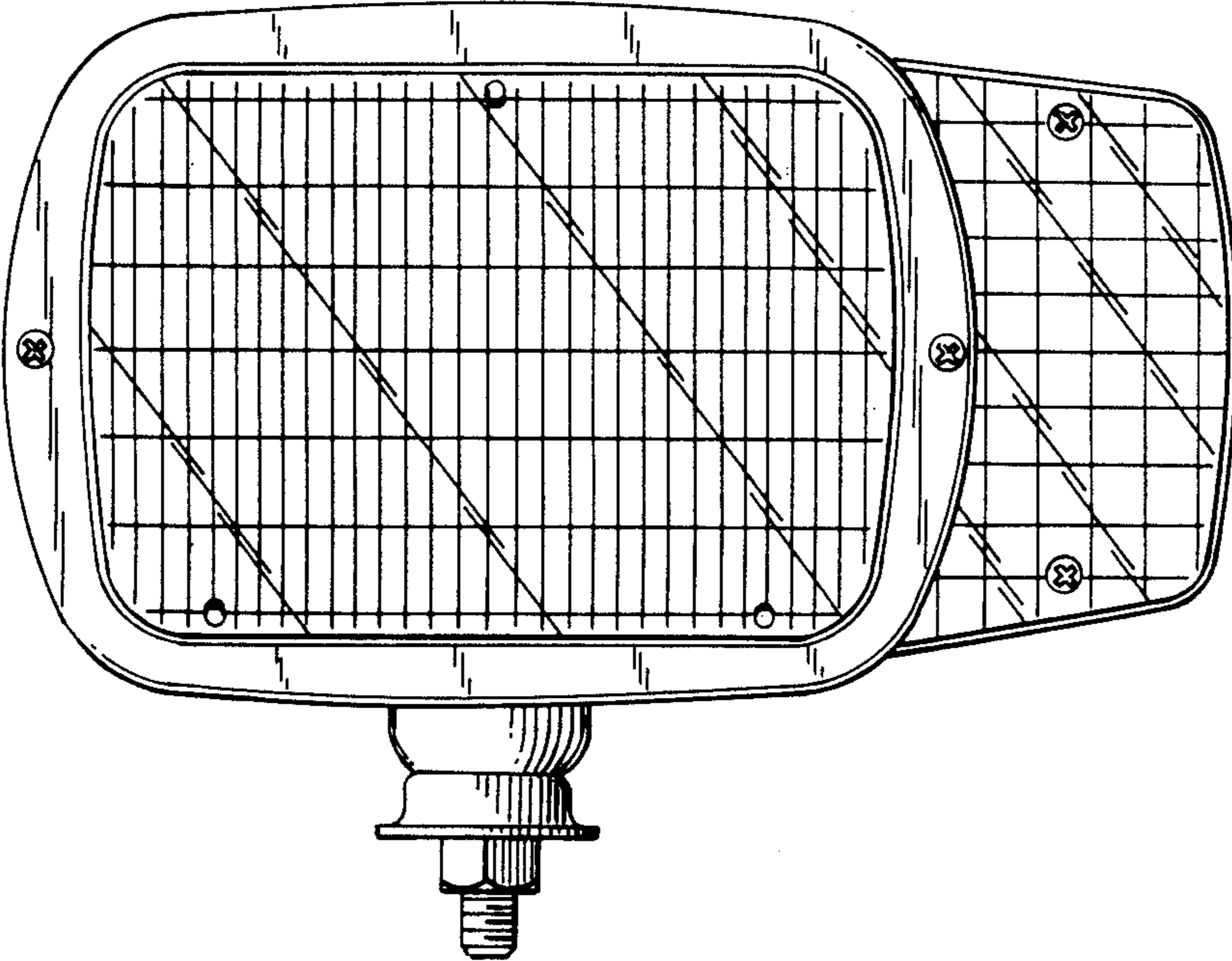

FIG. 3.

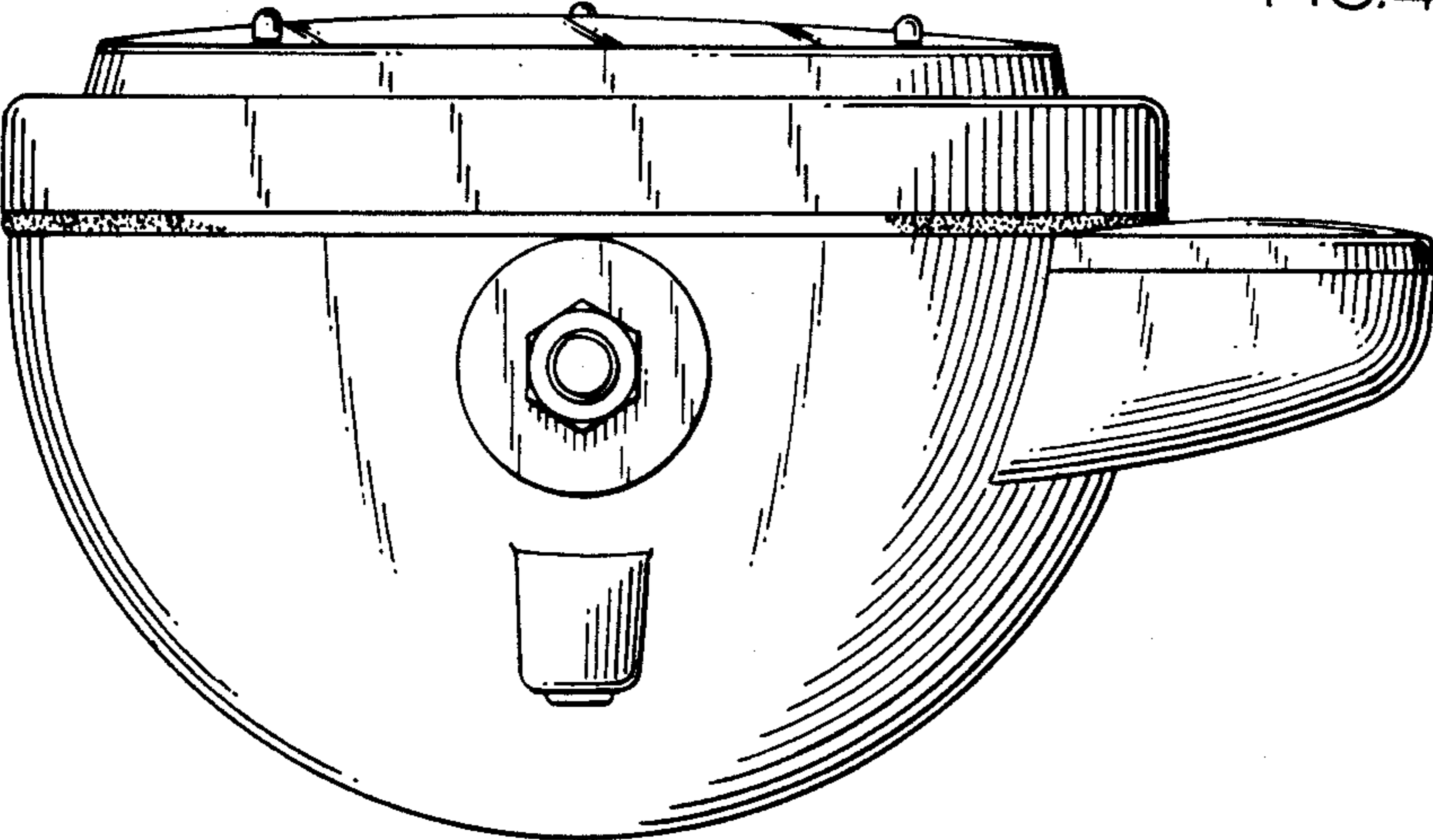

FIG. 4.

FIG.5.

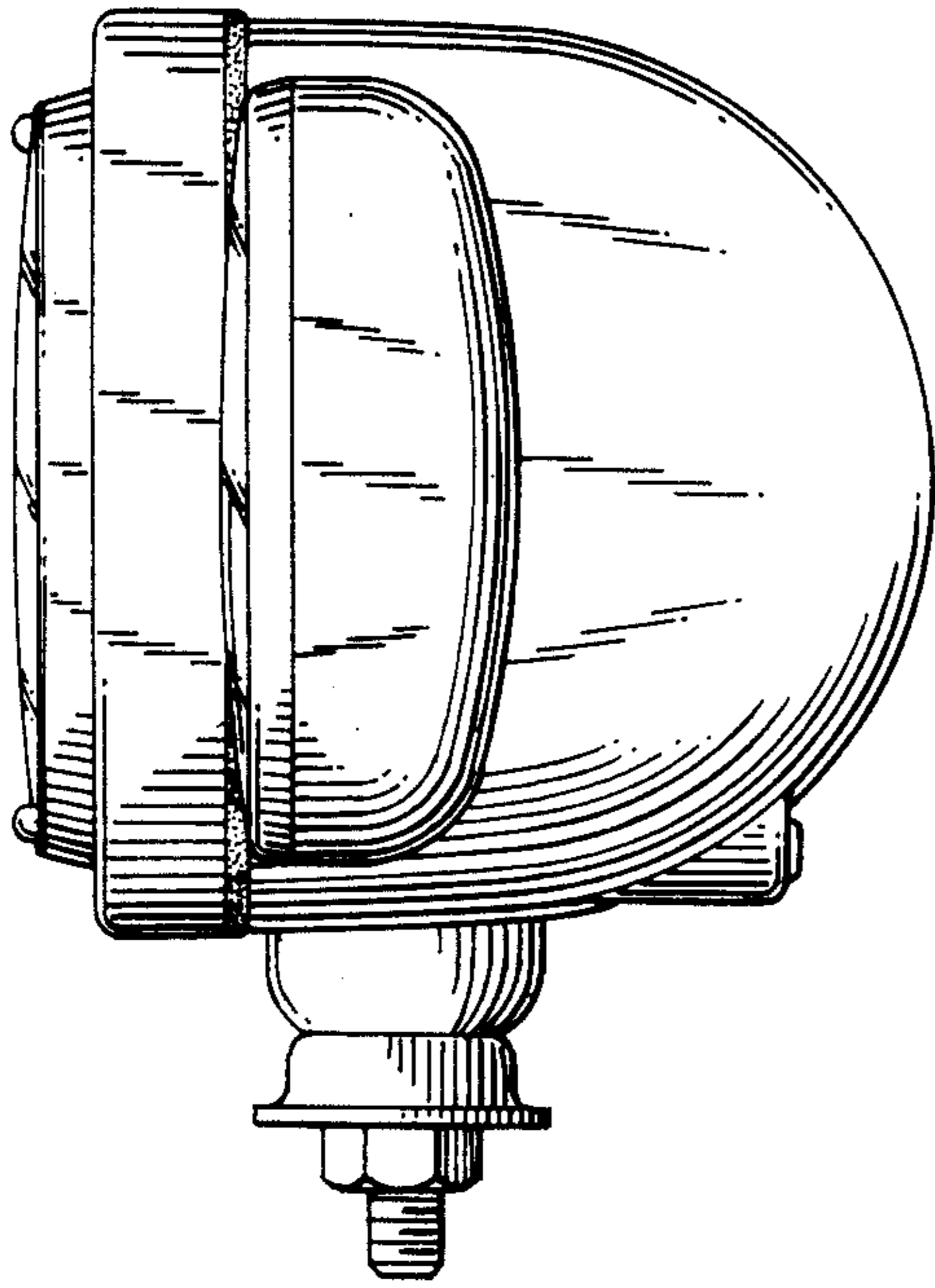

FIG.6.

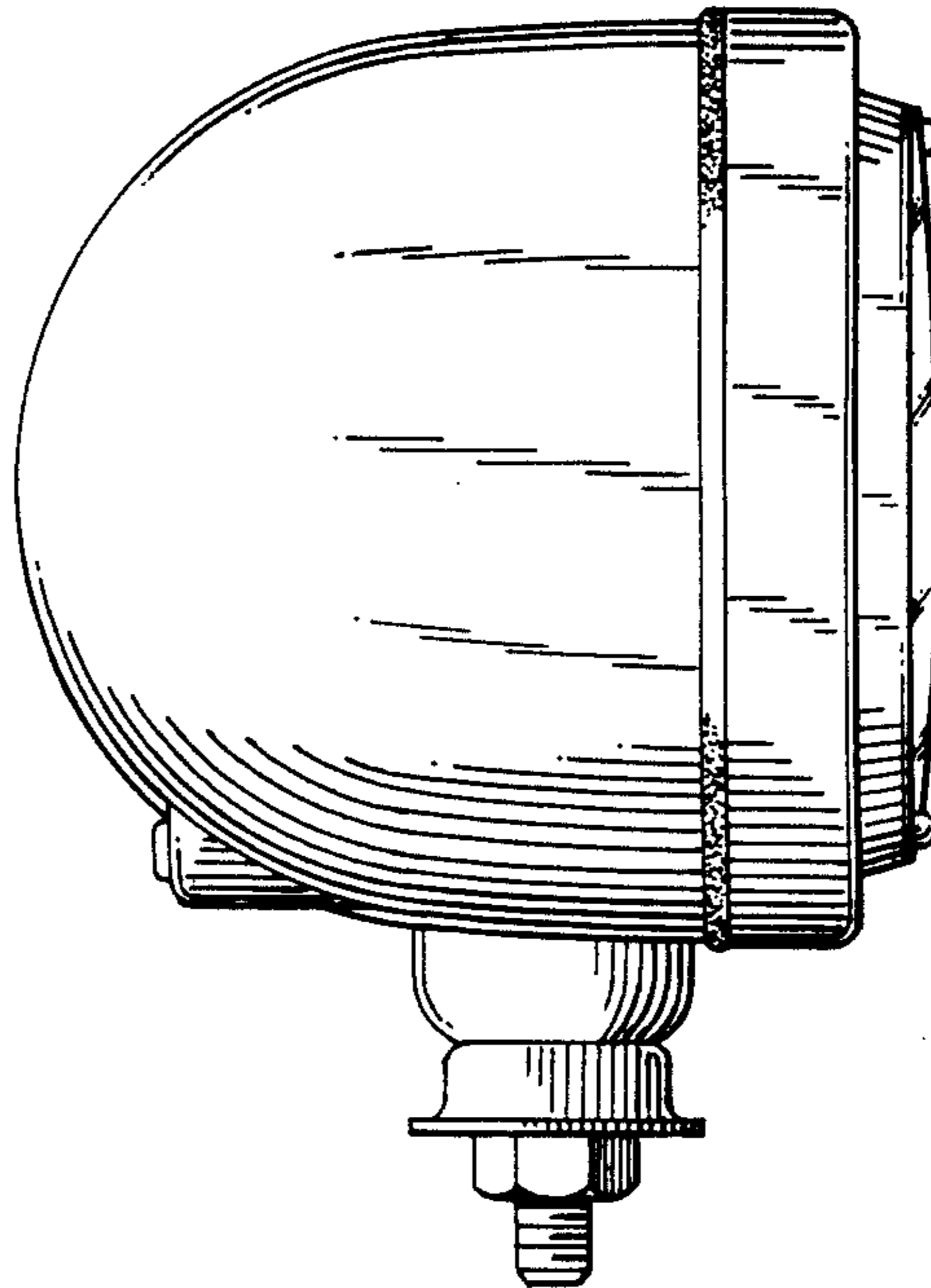

FIG.7.

