

[54] **COMBINED FLUSH MOUNTED TOW BAR AND BRUSH GUARD**

3,287,027 11/1966 Schuckman 280/491B

[76] Inventor: **Harry Stewart, 924 W. Jackson St., Pasadena, Tex. 77506**

FOREIGN PATENT DOCUMENTS

866085 3/1971 Canada 280/491 B

[**] Term: **14 Years**

Primary Examiner—James M. Gandy
Attorney, Agent, or Firm—Edmund F. Bard

[21] Appl. No.: **875,590**

[57] **CLAIM**

[22] Filed: **Feb. 6, 1978**

The ornamental design for a combined flush mounted tow bar and brush guard, substantially as shown.

[51] Int. Cl. **D12-16**

[52] U.S. Cl. **D12/162; D12/171**

[58] Field of Search **D12/162, 171; 280/491 R, 491 B; 293/115, 117**

DESCRIPTION

FIG. 1 is a front elevational view of a combined flush mounted tow bar and brush guard embodying my new design;

FIG. 2 is a side elevational view thereof;

FIG. 3 is an isometric view thereof; and

FIG. 4 is an isometric view thereof with the tow bar in extended position.

[56] **References Cited**

U.S. PATENT DOCUMENTS

2,880,016 3/1959 Peterson D12/171

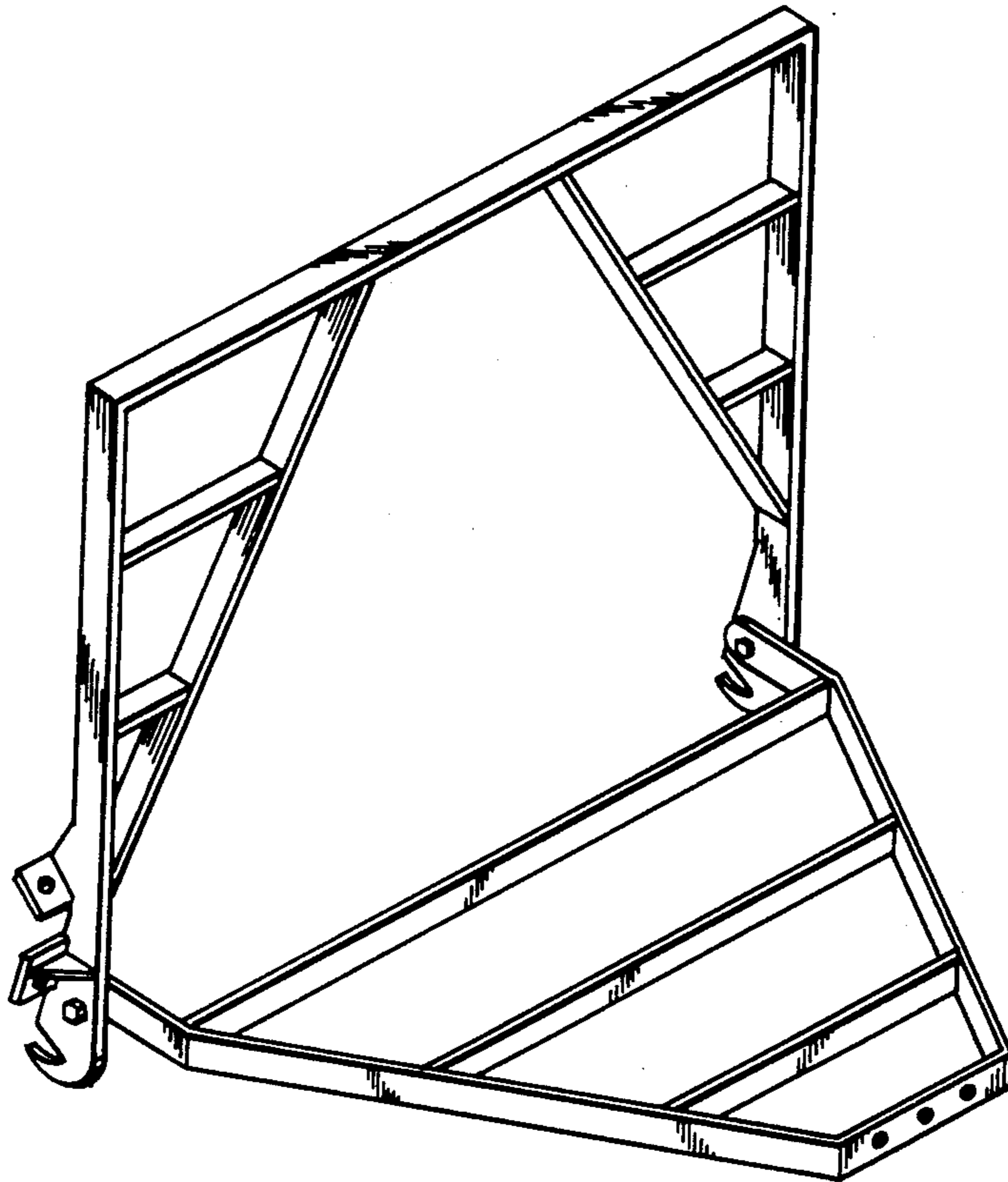

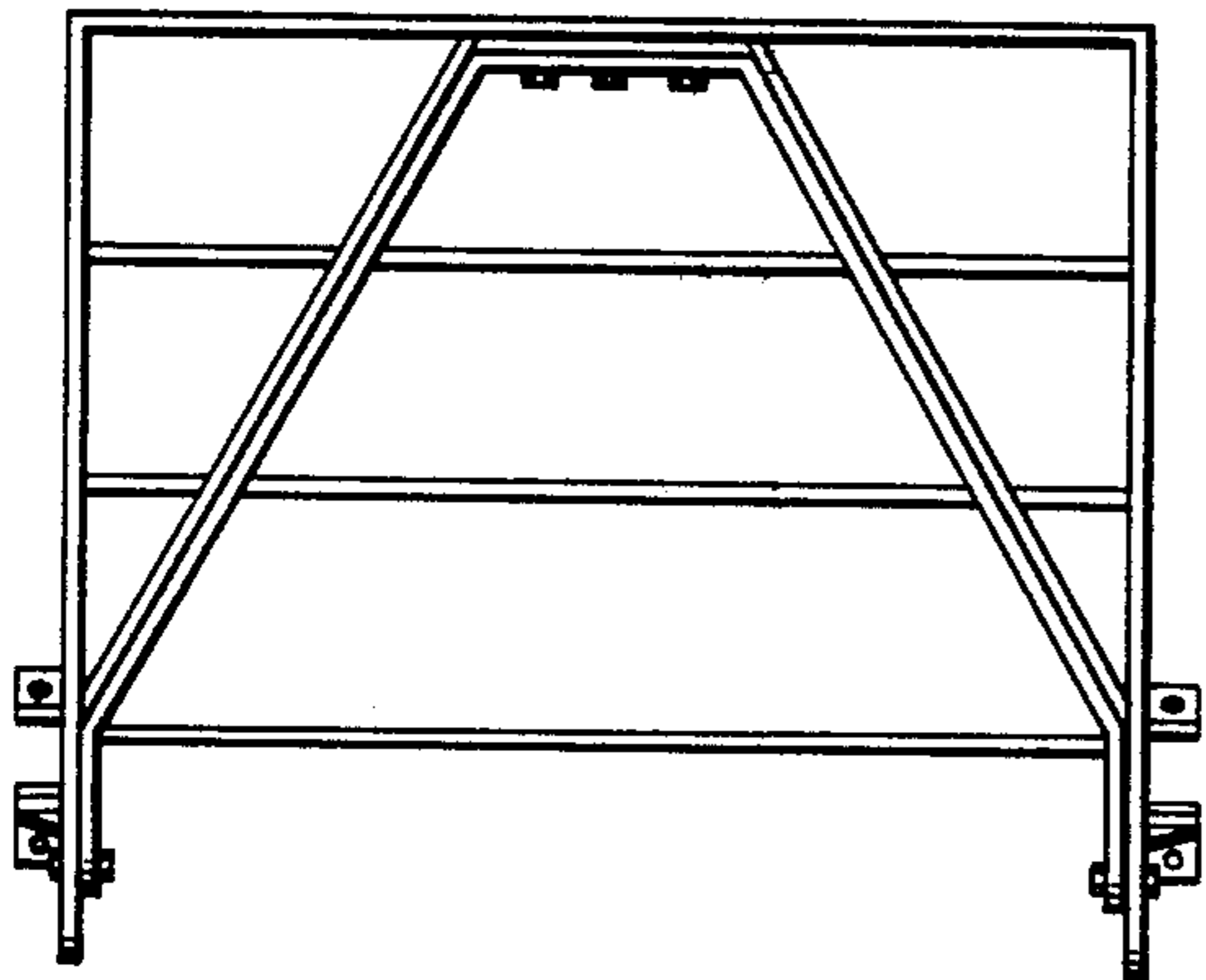

fig.1



fig.2

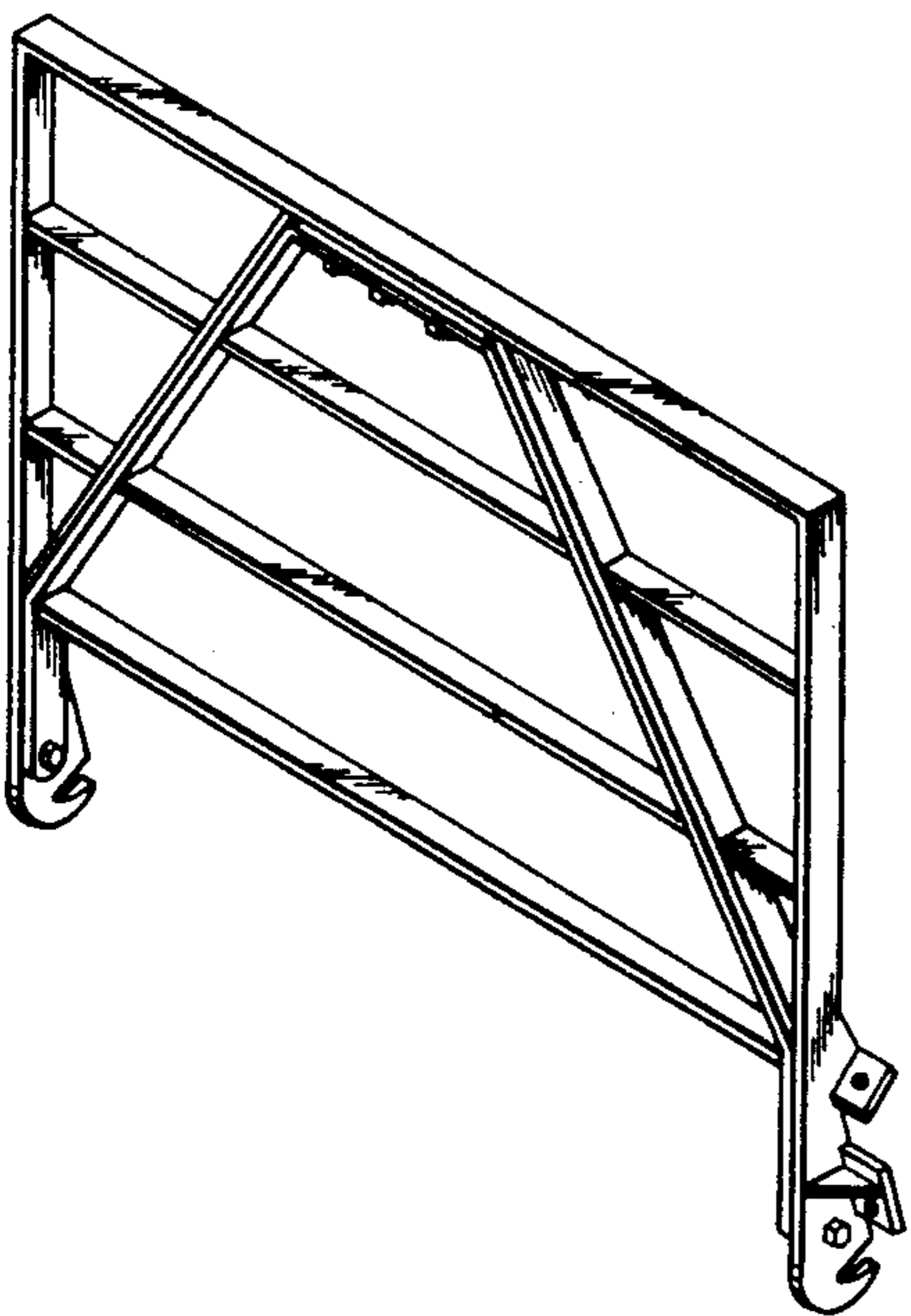

fig.3

fig.4

