

[54] DIGITAL ENGINE ANALYZER

[75] Inventor: Edwin L. Schwartz, Los Angeles, Calif.

[73] Assignee: Rite Autotronics Corporation, Los Angeles, Calif.

[**] Term: 14 Years

[21] Appl. No.: 841,686

[22] Filed: Oct. 13, 1977

[51] Int. Cl. D10-04

[52] U.S. Cl. D10/75; D10/78

[58] Field of Search D10/46, 75, 78, 102, D10/103, 47, 57, 60; 73/117, 117.3, 116; 324/15 R, 16 R, 16 T, 149, 156

[56] References Cited

U.S. PATENT DOCUMENTS

3,757,218 9/1973 Oliverio 324/149 X

3,792,445 2/1974 Bucks 73/116 X
3,906,437 9/1975 Brandwein 73/117.3 X
3,990,302 11/1976 Reeves 73/116

Primary Examiner—Nelson C. Holtje
Attorney, Agent, or Firm—Robert E. Geauque

[57] CLAIM

The ornamental design for a digital engine analyzer, substantially as shown.

DESCRIPTION

FIG. 1 is a right front perspective view of a digital engine analyzer showing my new design; FIG. 2 is a front elevational view thereof; FIG. 3 is a right side elevational view thereof, the left side being a mirror image thereto; FIG. 4 is a top plan view thereof; FIG. 5 is a bottom plan view thereof; FIG. 6 is a rear elevational view thereof; and FIG. 7 is a front perspective view thereof in the raised position.

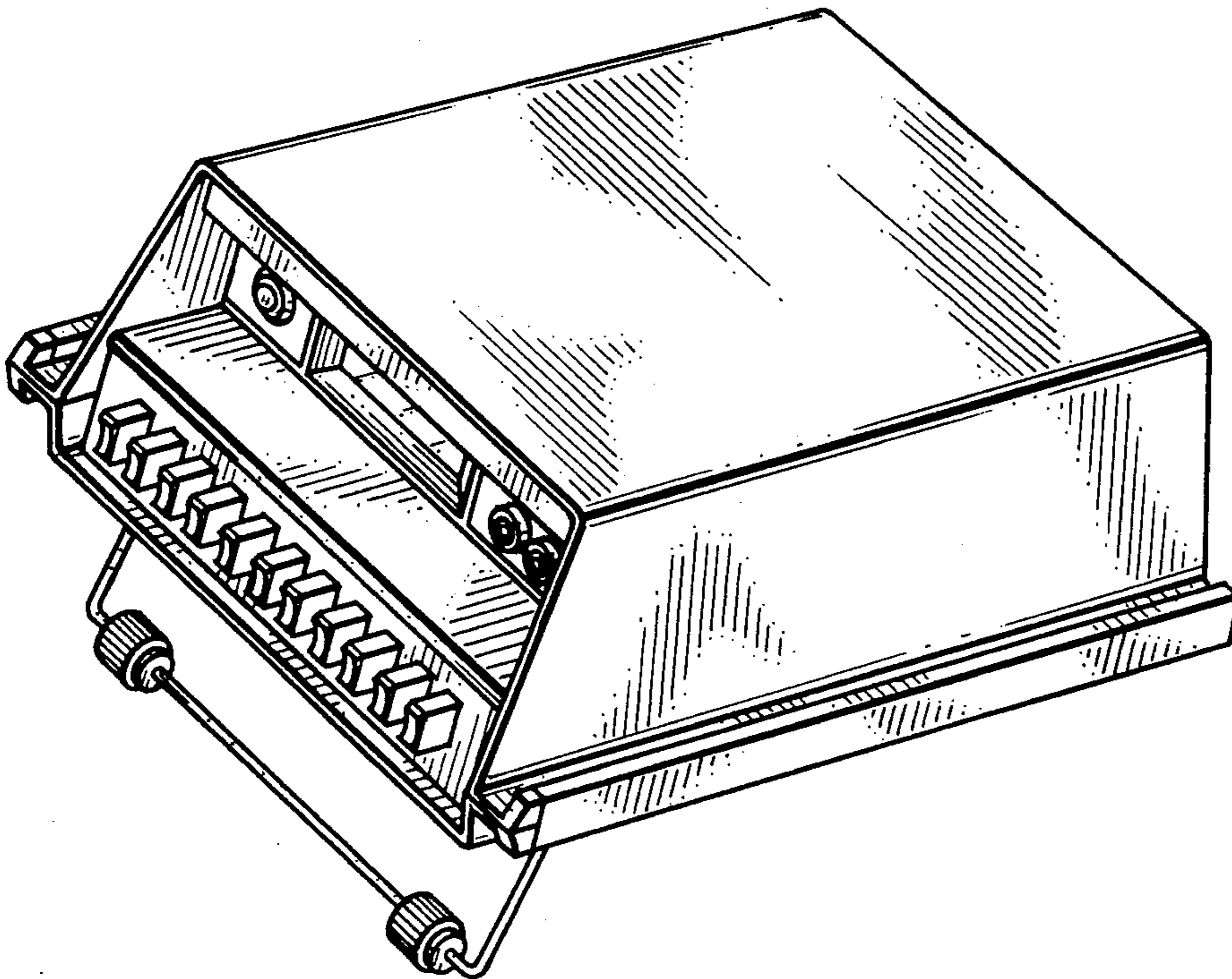

Fig. 1.

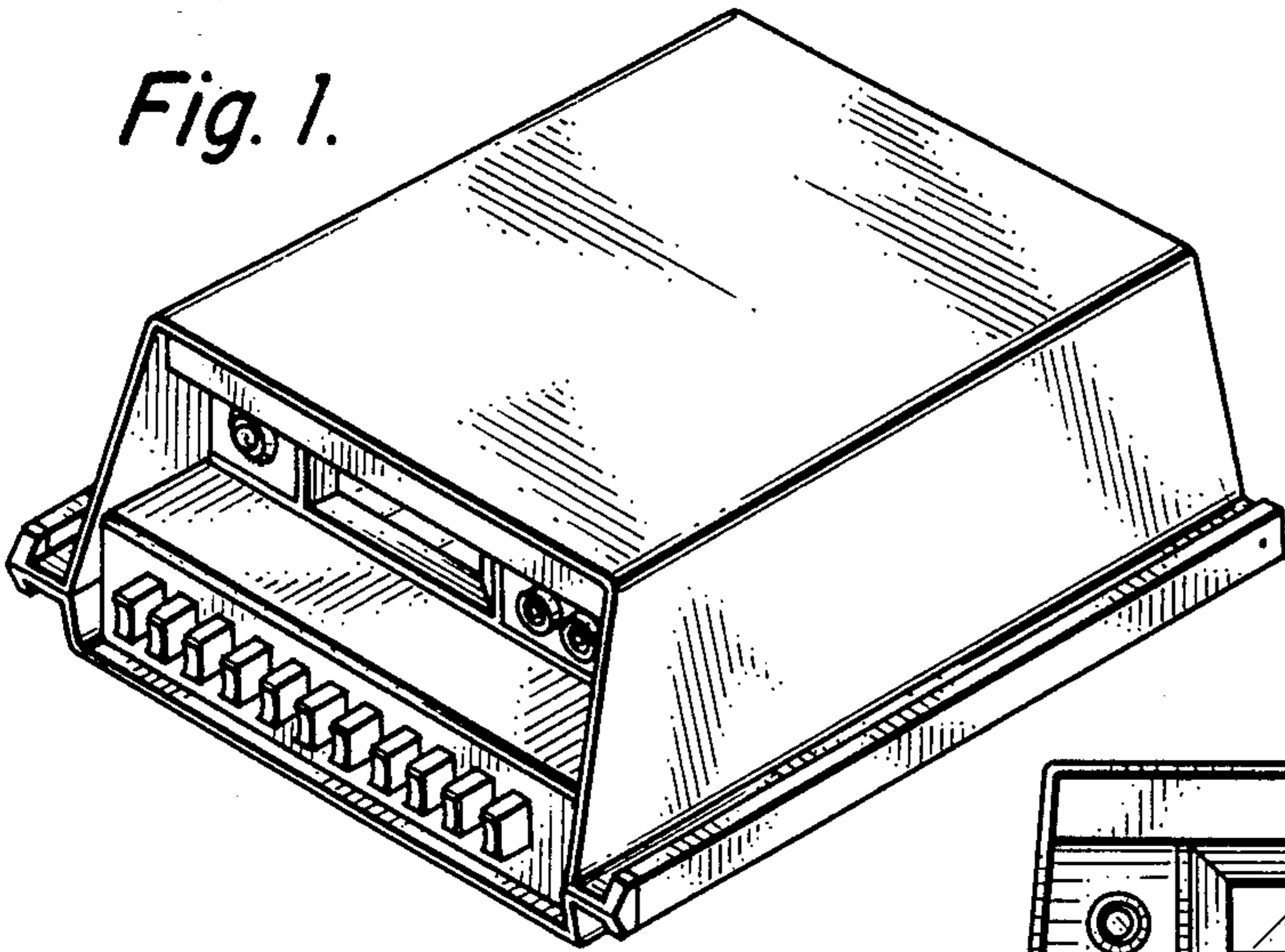

Fig. 2.

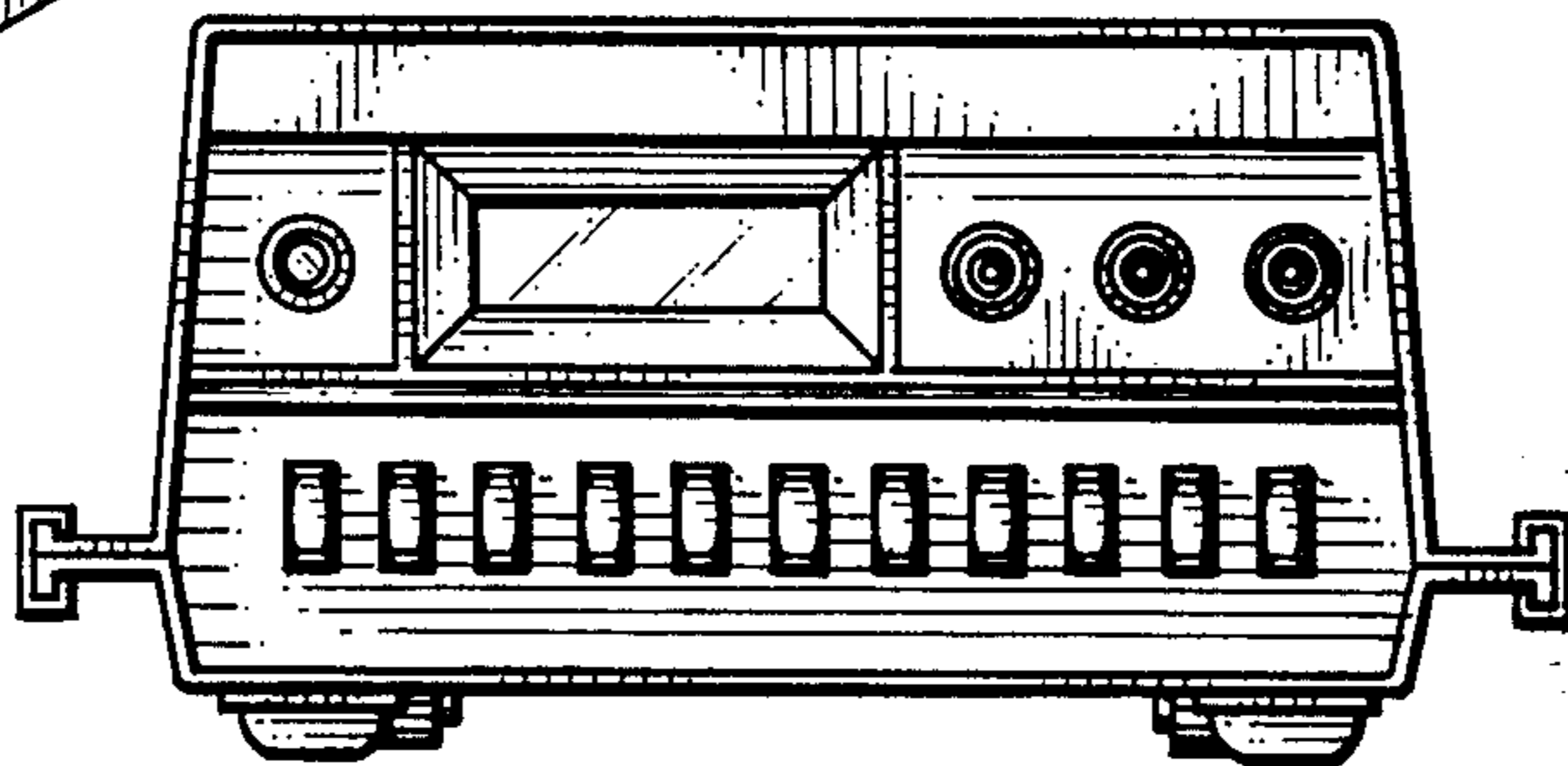

Fig. 3.

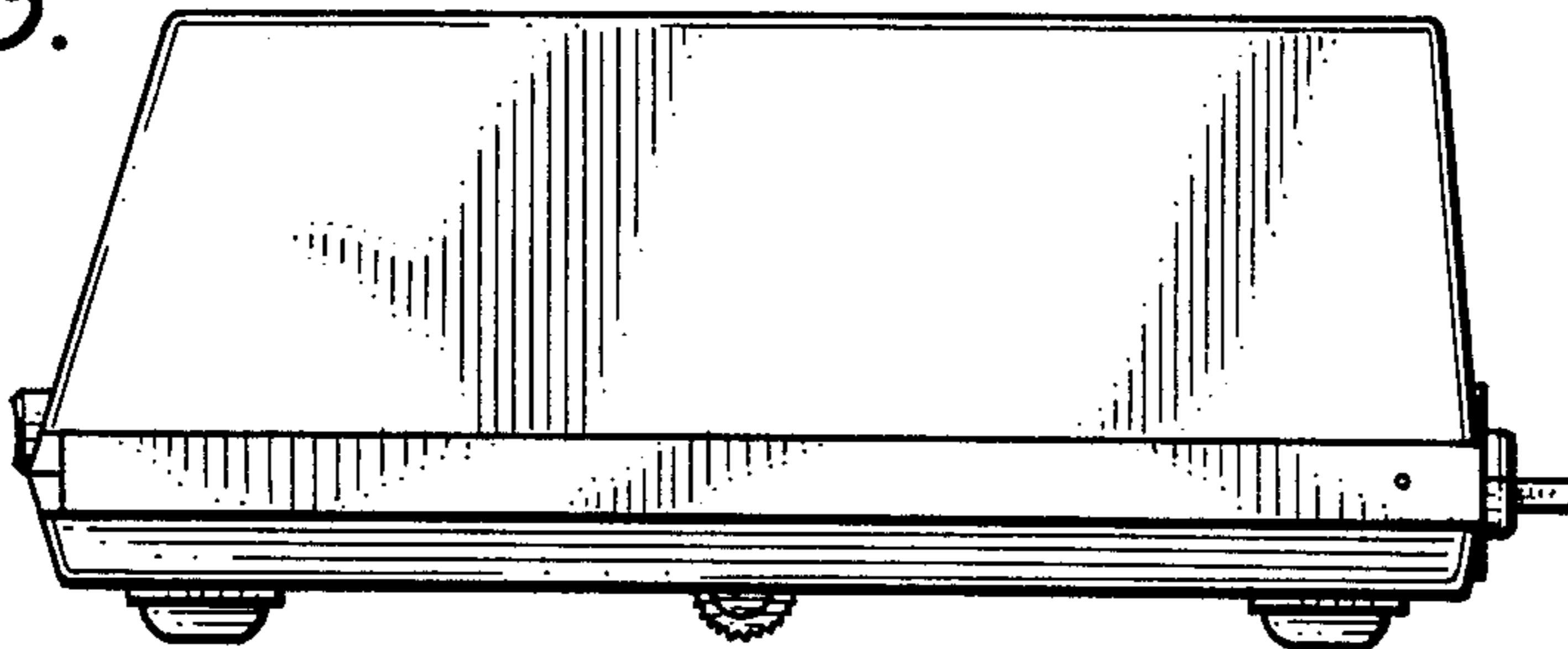

Fig. 4.

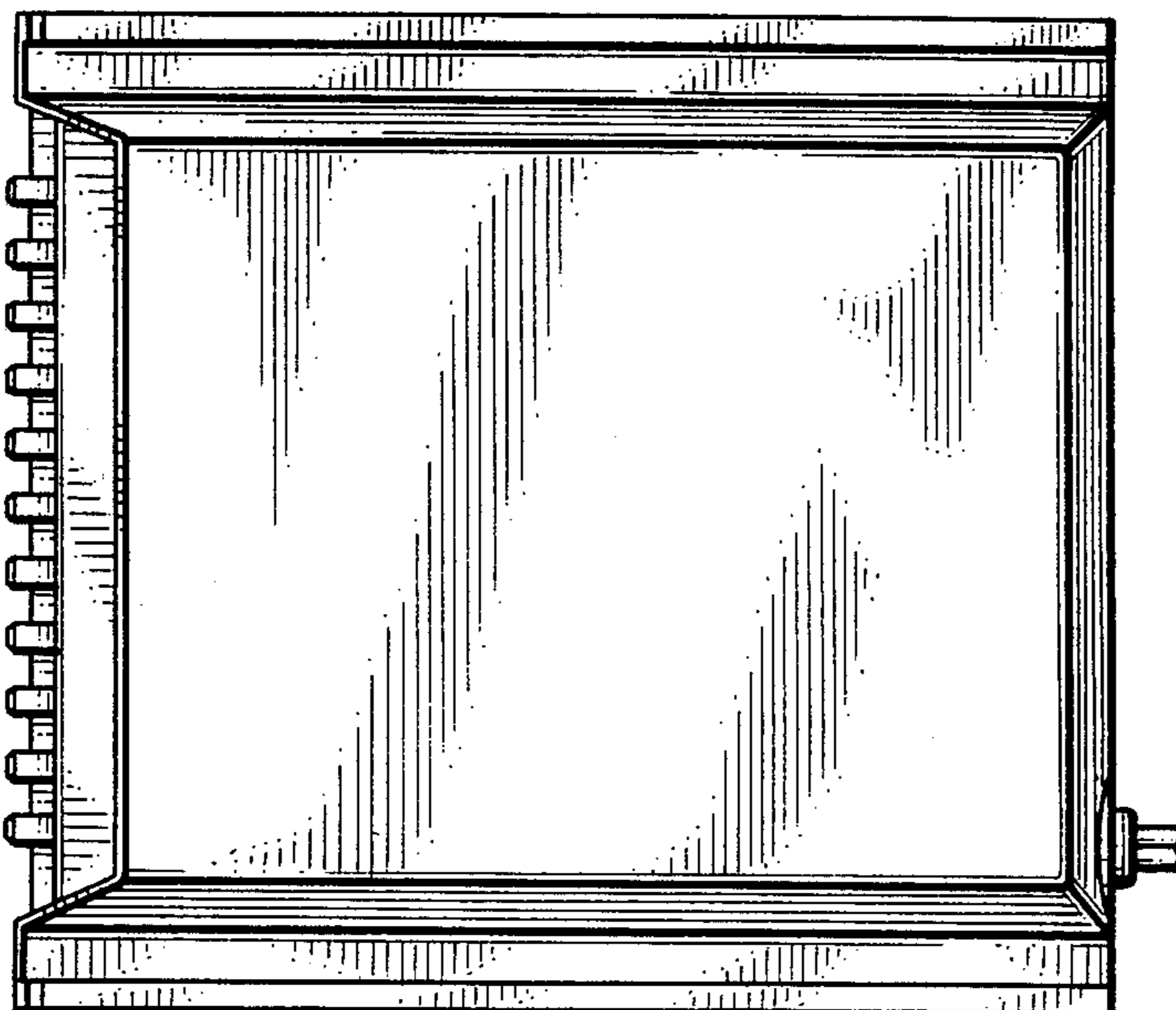

Fig. 5.

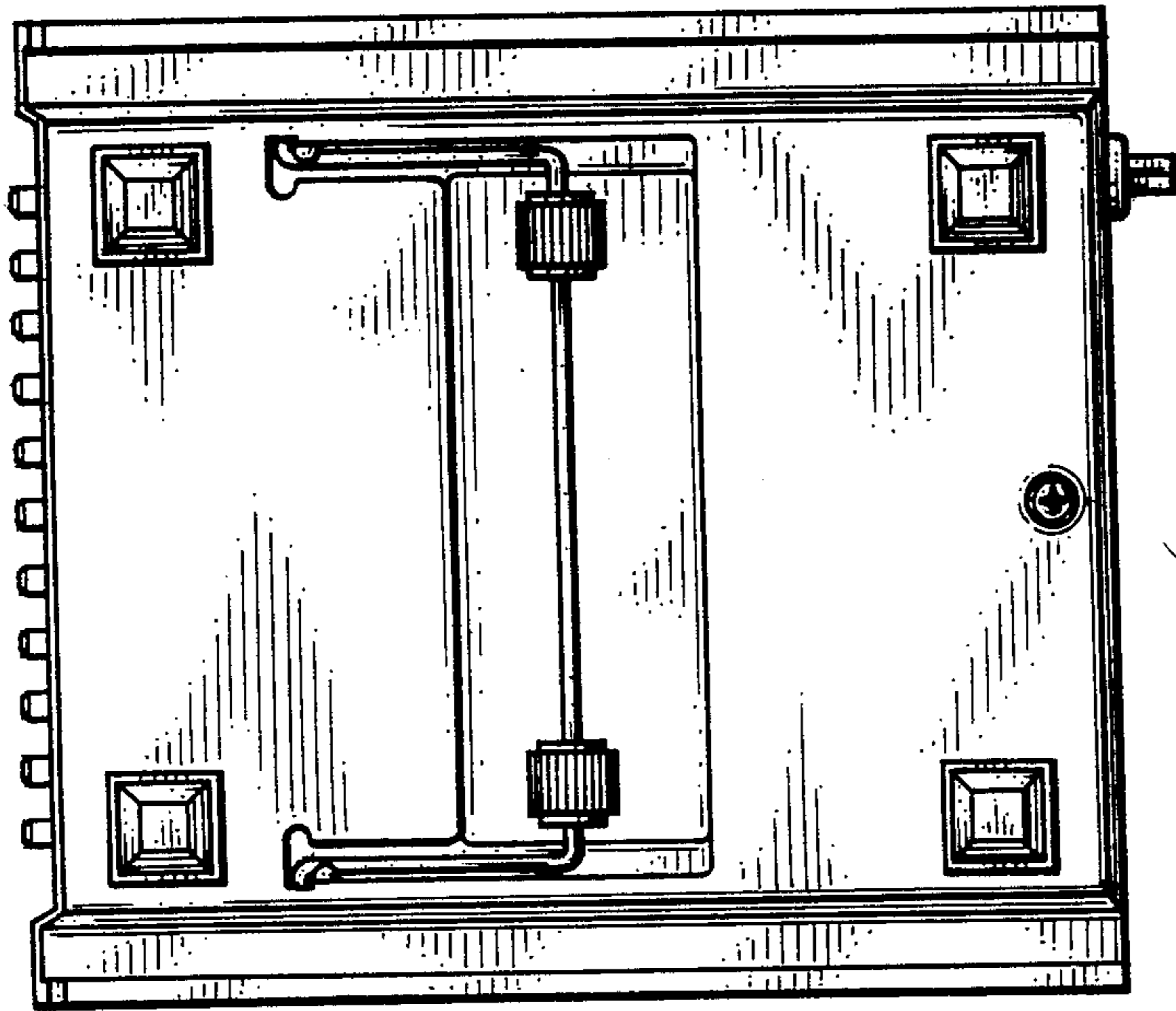

Fig. 6.

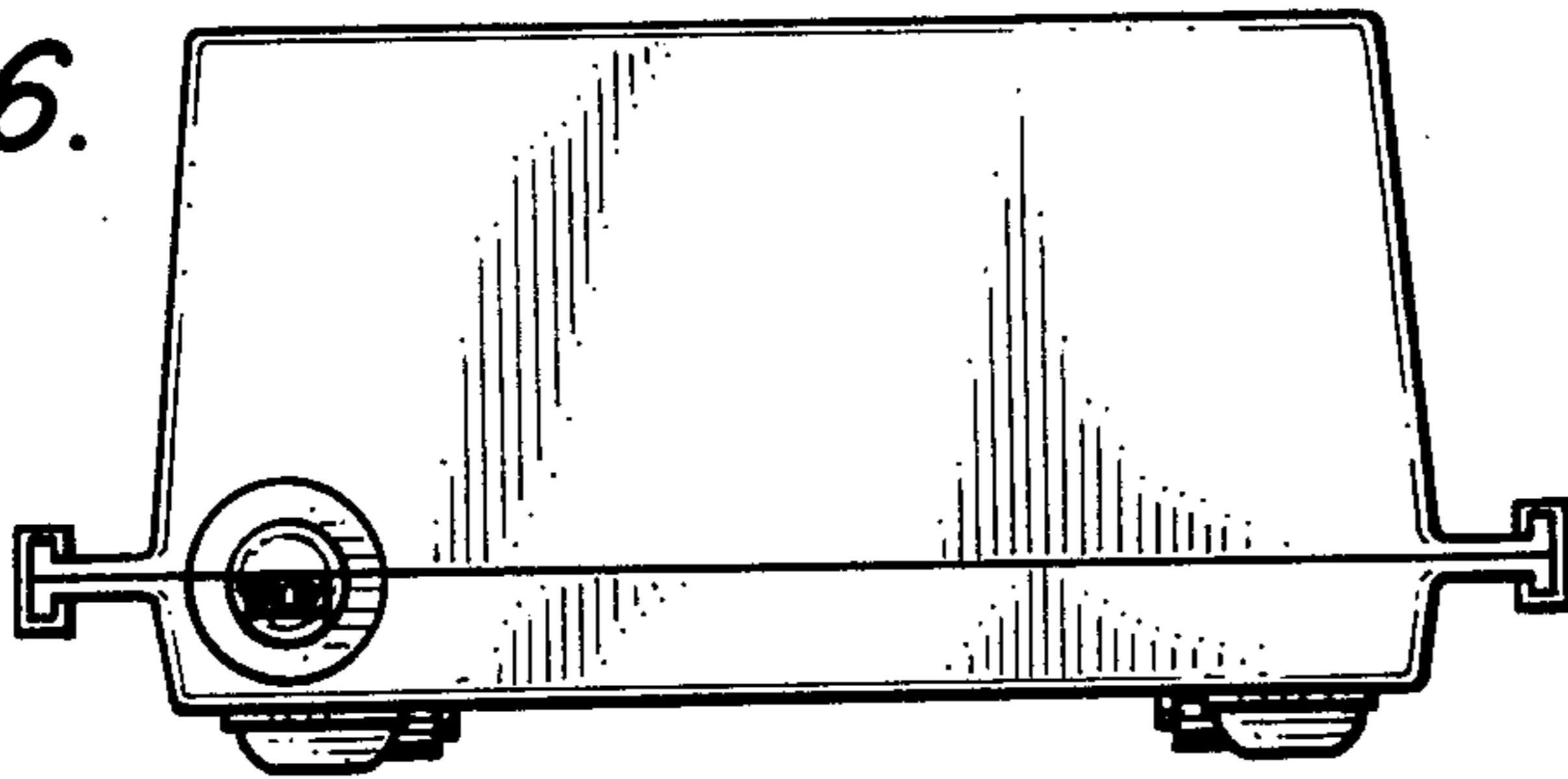

Fig. 7.

