

[54] SIMULATIVE TOY VEHICLE

[75] Inventors: Lawrence T. Jones, Playa Del Rey; Robert S. Lee, Westlake; Anson Sims, Granada Hills, all of Calif.

[73] Assignee: California R & D Center, Culver City, Calif.

[**] Term: 14 Years

[21] Appl. No.: 10,831

[22] Filed: Feb. 9, 1979

[51] Int. Cl. D21-01

[52] U.S. Cl. D21/128; D21/185

[58] Field of Search D21/71, 76, 78, 79, D21/128, 133, 134, 137, 140, 139, 185; 46/201, 202, 222, 74 R, 115, 124

[56] References Cited

U.S. PATENT DOCUMENTS

D. 137,692	4/1944	Reinecke	D21/185
D. 145,066	6/1946	Catanzarite et al.	D21/185
D. 165,785	10/1951	Lustig	D21/185

Primary Examiner—Charles A. Rademaker
Attorney, Agent, or Firm—Jackson, Jones & Price

[57] CLAIM

The ornamental design for a simulative toy vehicle, substantially as shown and described.

DESCRIPTION

FIG. 1 is a front elevational view of a simulative toy vehicle showing our new design; FIG. 2 is a top plan view thereof; FIG. 3 is a bottom plan view thereof; FIG. 4 is a side elevational view thereof, the side opposite being substantially a mirror image; and, FIG. 5 is a rear elevational view thereof.

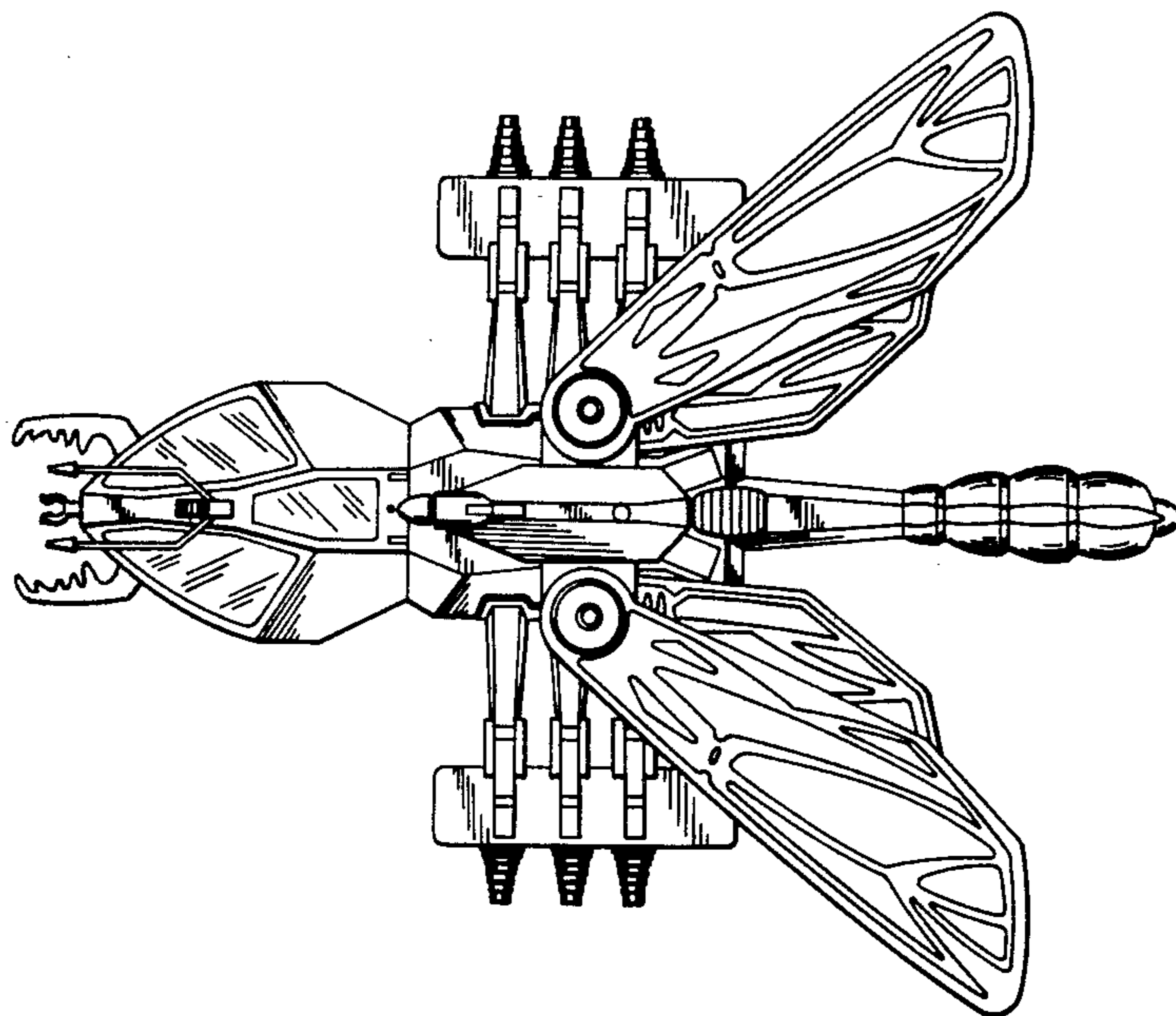

FIG. 1

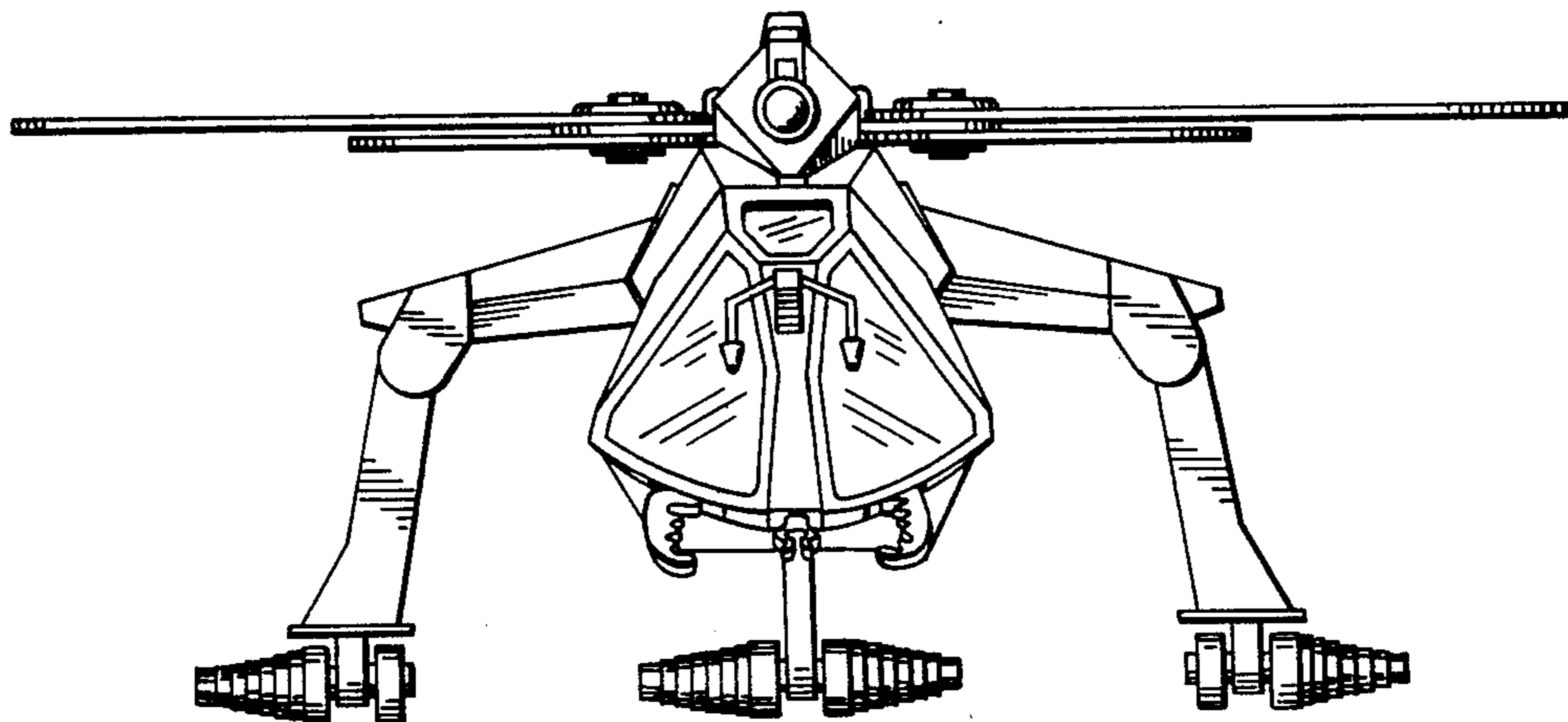

FIG. 2

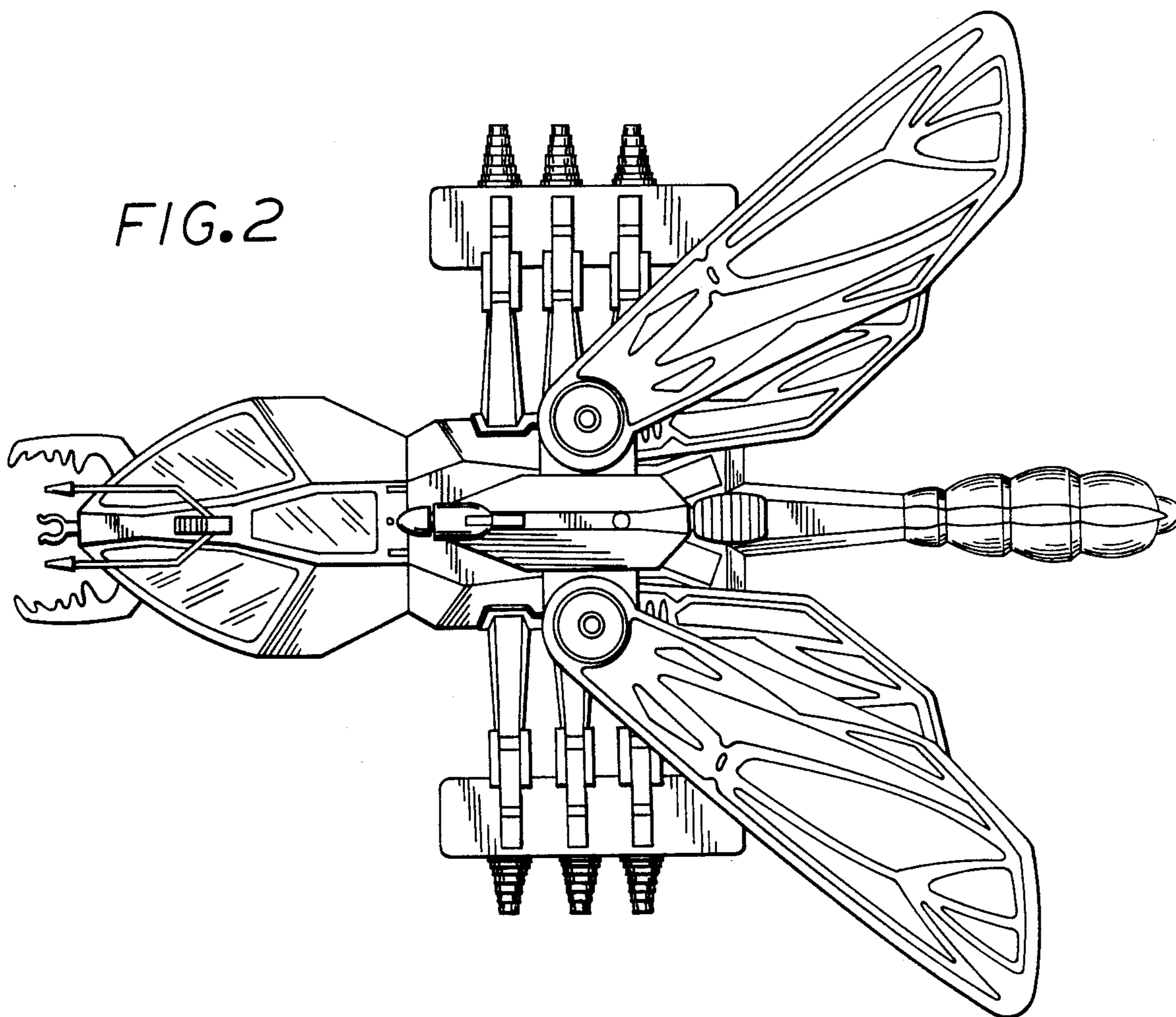

FIG. 3

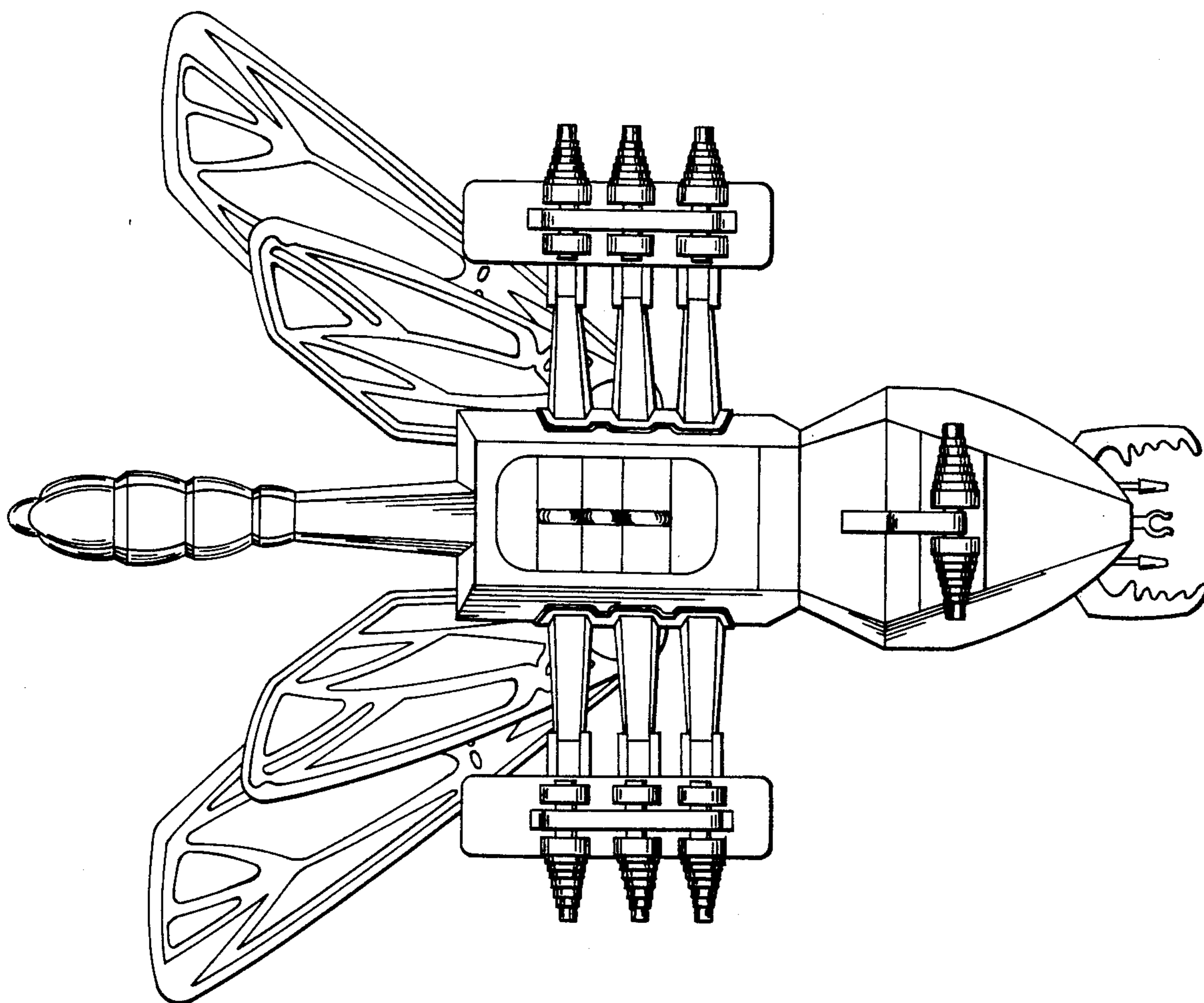

FIG. 4

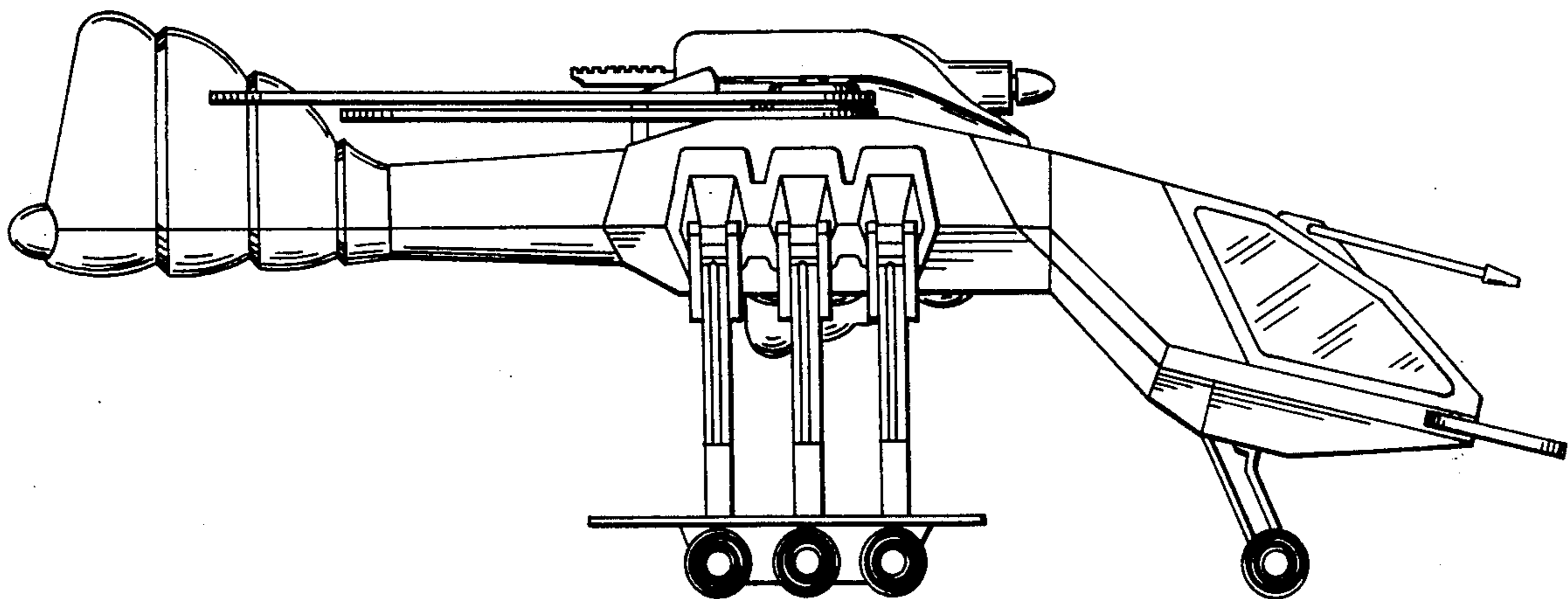

FIG. 5

