

[54] VEHICLE RADAR DETECTOR HOUSING

[75] Inventor: Ronald E. Natinsky, Dallas, Tex.  
[73] Assignee: Brinkmann Corporation, Dallas, Tex.  
[\*\*] Term: 14 Years  
[21] Appl. No.: 823,192  
[22] Filed: Aug. 9, 1977

[51] Int. Cl. .... D10-06  
[52] U.S. Cl. .... D10/104  
[58] Field of Search ..... D10/104, 106, 121;  
343/5 PD, 18 E; D14/40, 41, 12; D13/40, 41;  
248/274, 284, 309

[56] References Cited

U.S. PATENT DOCUMENTS

D. 218,439 8/1970 Horowitz et al. .... D10/106  
4,065,087 12/1977 Solden ..... D10/106 X

OTHER PUBLICATIONS

J. C. Whitney & Co. Auto Accessories Catalog #350, 1976, p. 44 Electronic Speed Warning Signal.

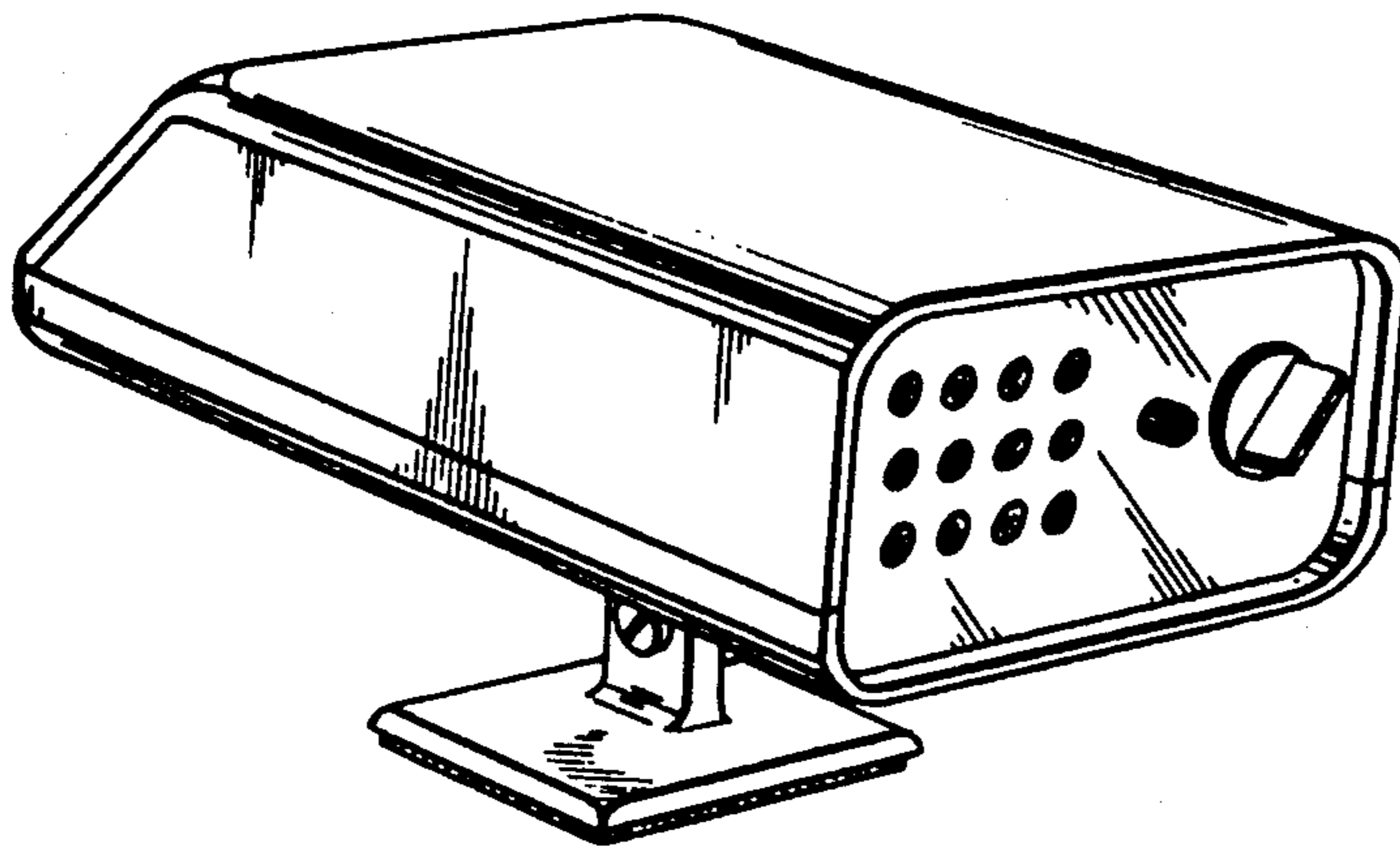
Primary Examiner—Susan J. Lucas  
Attorney, Agent, or Firm—John R. Kirk, Jr.

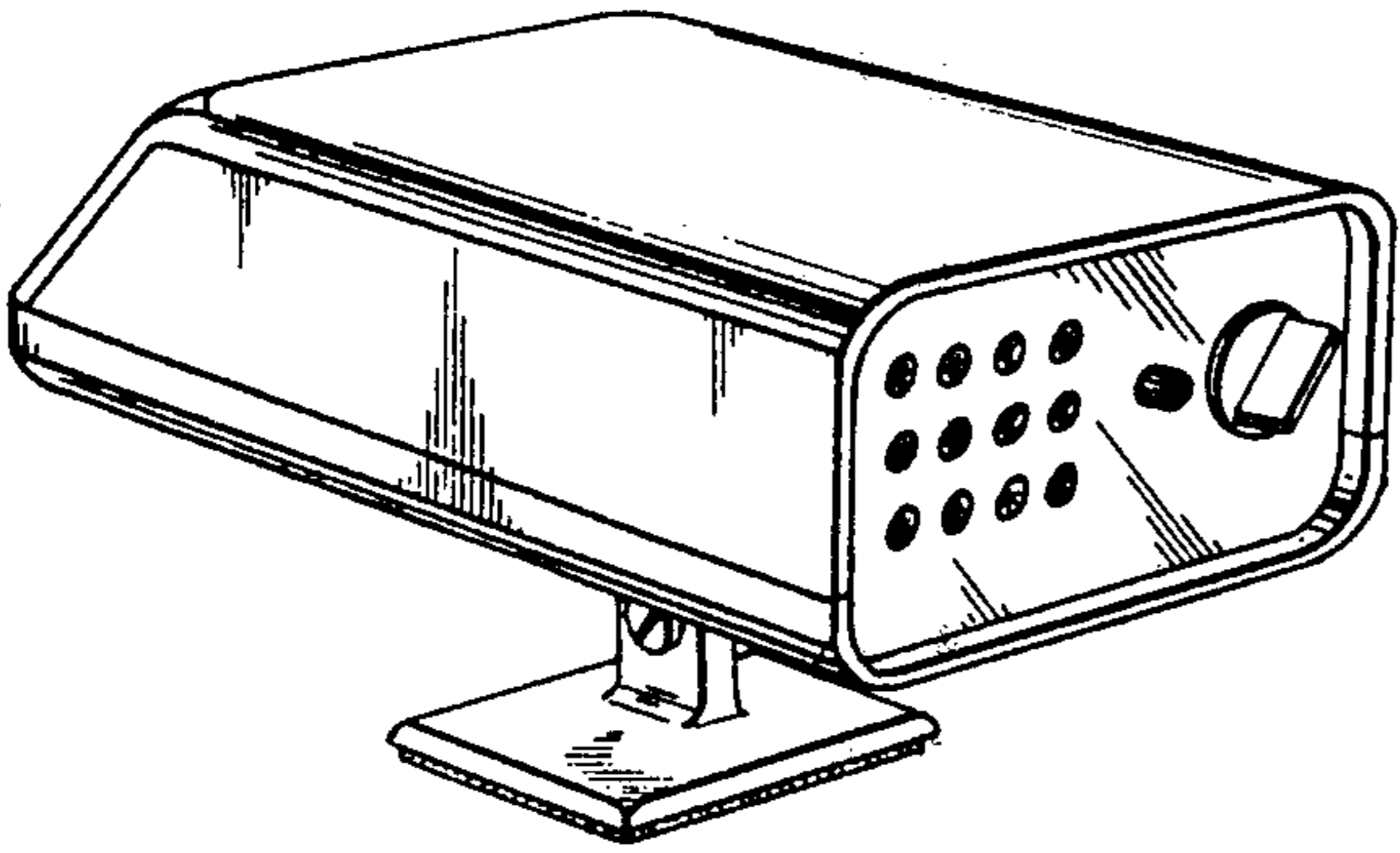
[57] CLAIM

The ornamental design for vehicle radar detector housing, substantially as shown and described.

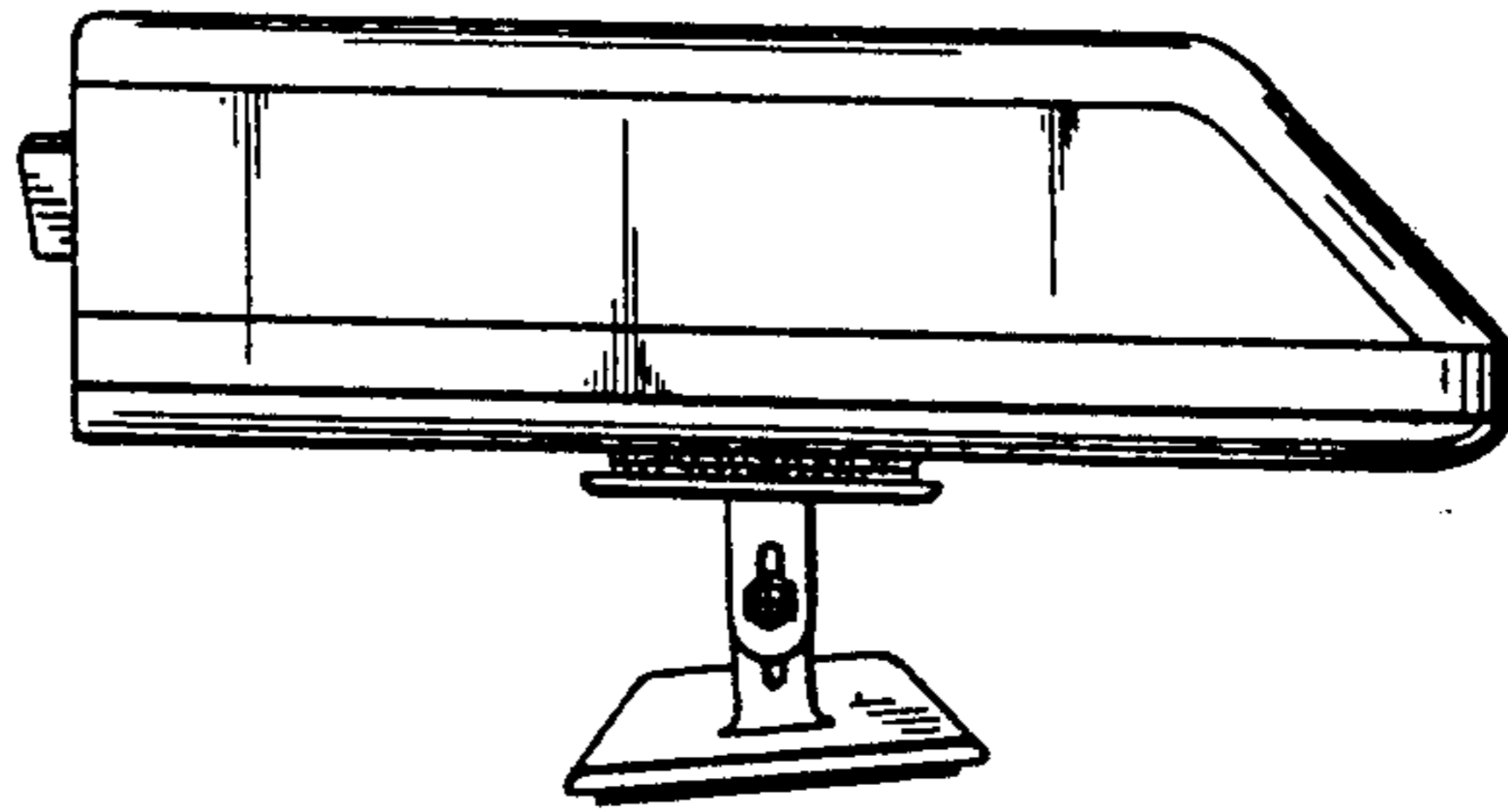
DESCRIPTION

FIG. 1 is a perspective view of a vehicle radar detector housing of my new design, illustrating the front, top, and left side thereof;  
FIG. 2 is a right side view thereof;  
FIG. 3 is a front view thereof; and  
FIG. 4 is a perspective view, on a reduced scale illustrating the rear, top, and left side thereof;  
FIG. 5 is a right side elevational view thereof.



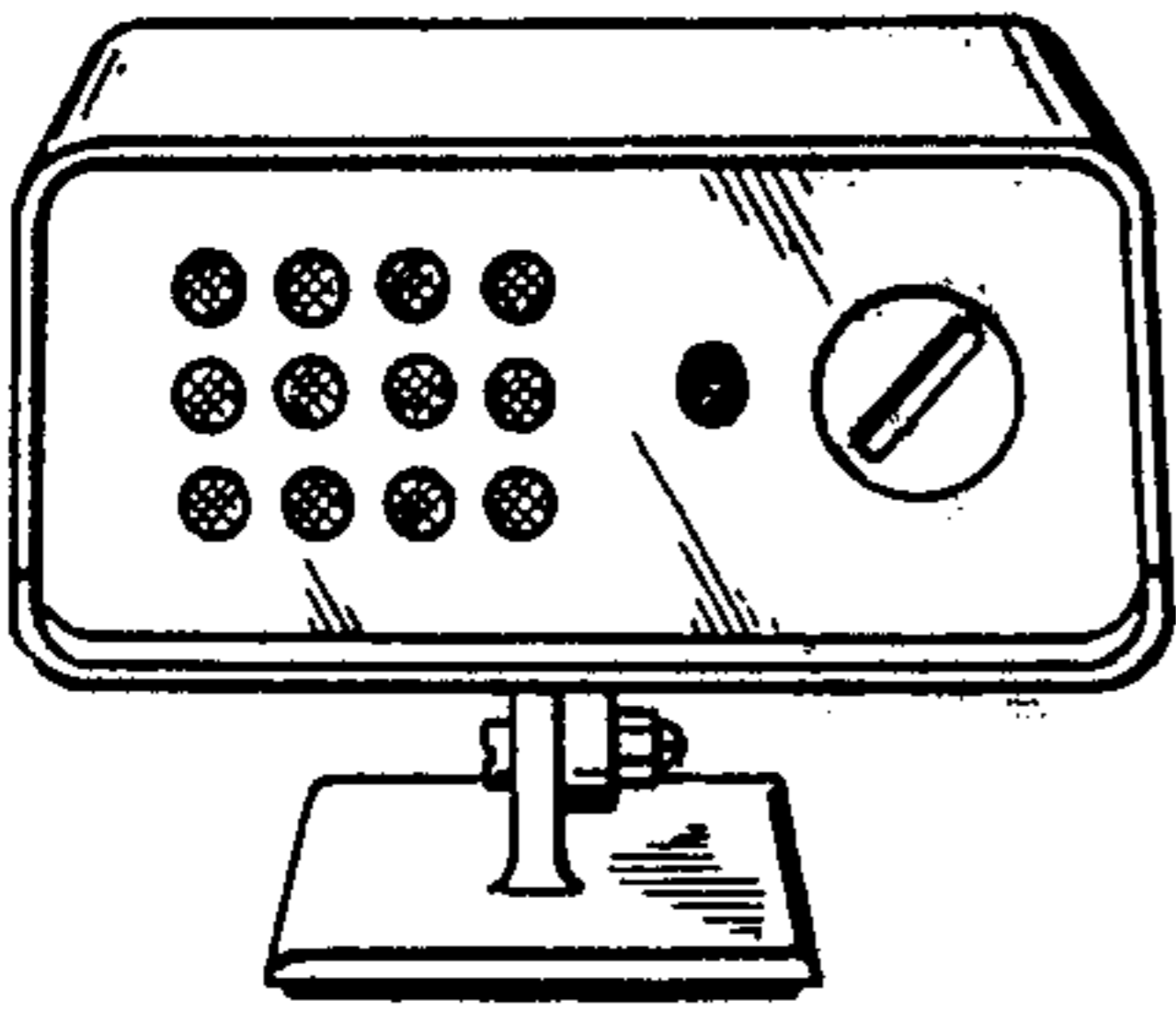


*Fig. 1*

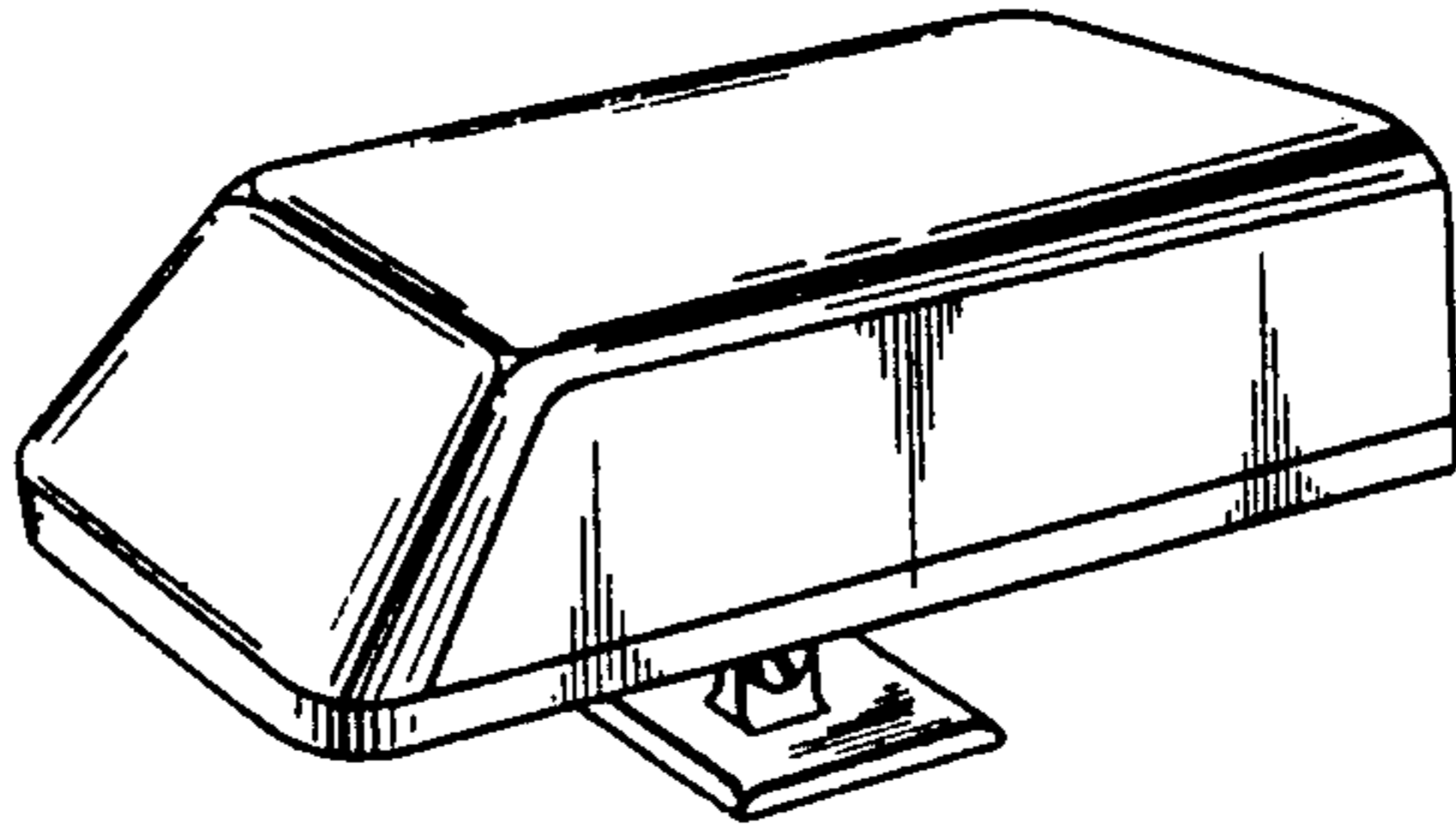


*Fig. 2*

*Fig. 3*



*Fig. 4*



*Fig. 5*

