

[54] AIRPLANE

[56]

References Cited

U.S. PATENT DOCUMENTS

[76] Inventor: Gerald L. Jonas, 2217 Pacific Ave., #4, San Francisco, Calif. 94115

D. 189,326 11/1960 Thieblot D12/78
D. 245,157 7/1977 Seidel D12/80

[**] Term: 14 Years

Primary Examiner—Sam Rosen
Attorney, Agent, or Firm—Sheldon R. Meyer

[21] Appl. No.: 929,112

[57] CLAIM

The ornamental design for an airplane, as shown.

[22] Filed: Jul. 28, 1978

DESCRIPTION

[51] Int. Cl. D12-07

[52] U.S. Cl. D12/78

[58] Field of Search D12/71, 78; 244/45 A,
244/45 R, 15

FIG. 1 is a top plan view of the airplane showing my new design;
FIG. 2 is a rear elevation view thereof;
FIG. 3 is a front elevation view thereof;
FIG. 4 is a bottom plan view thereof;
FIG. 5 is a side elevation view taken from the right of FIG. 6; and
FIG. 6 is a top and right side perspective view thereof.

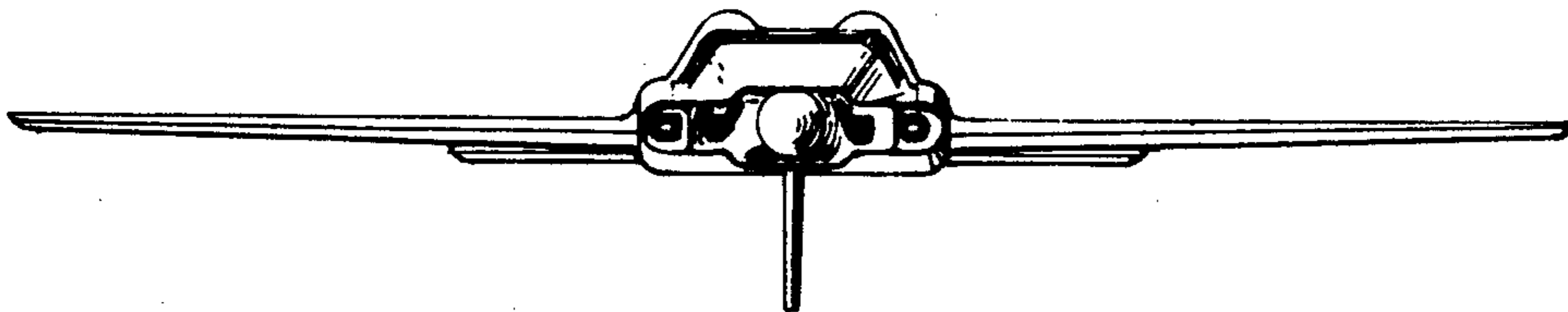
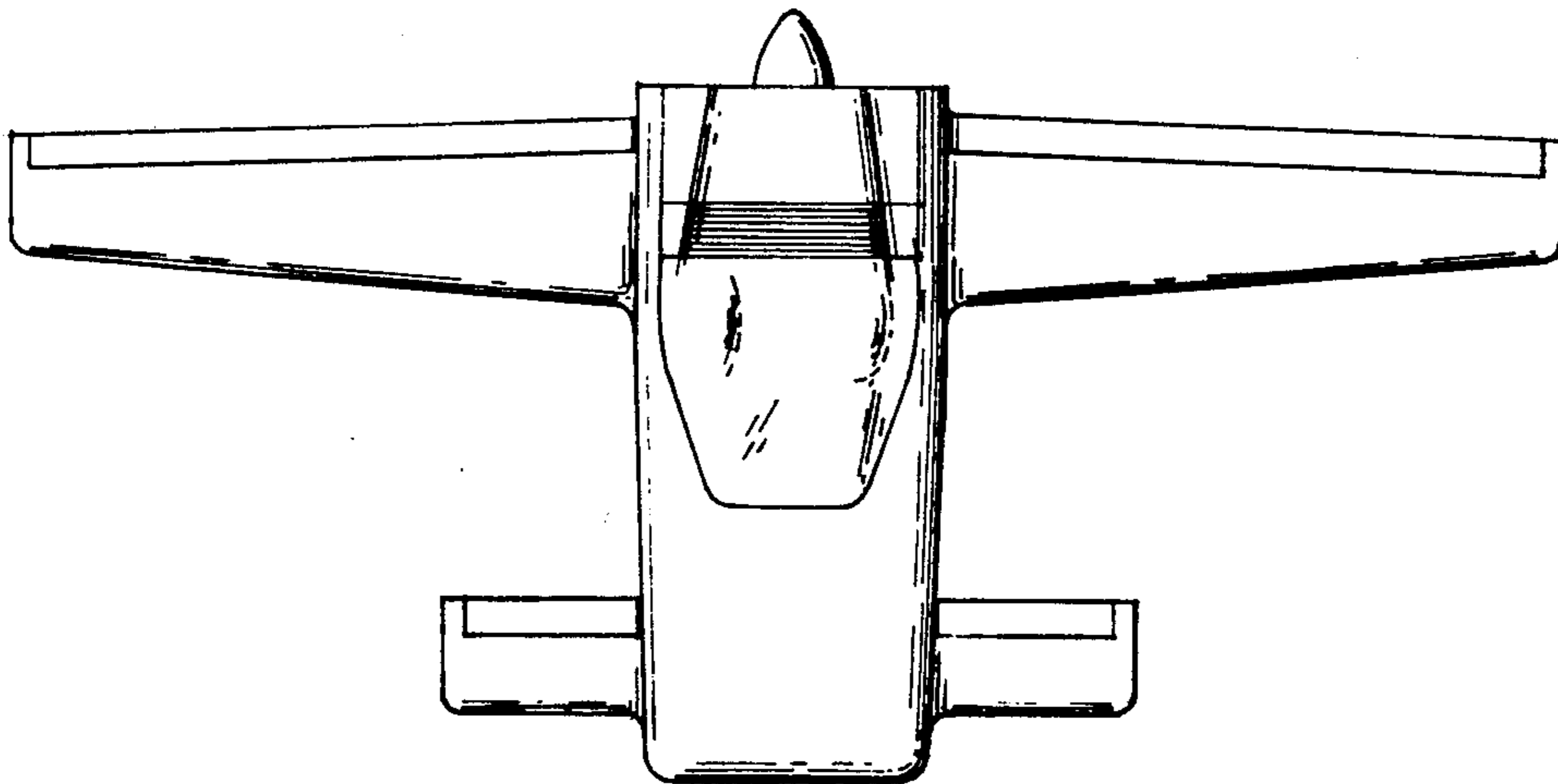

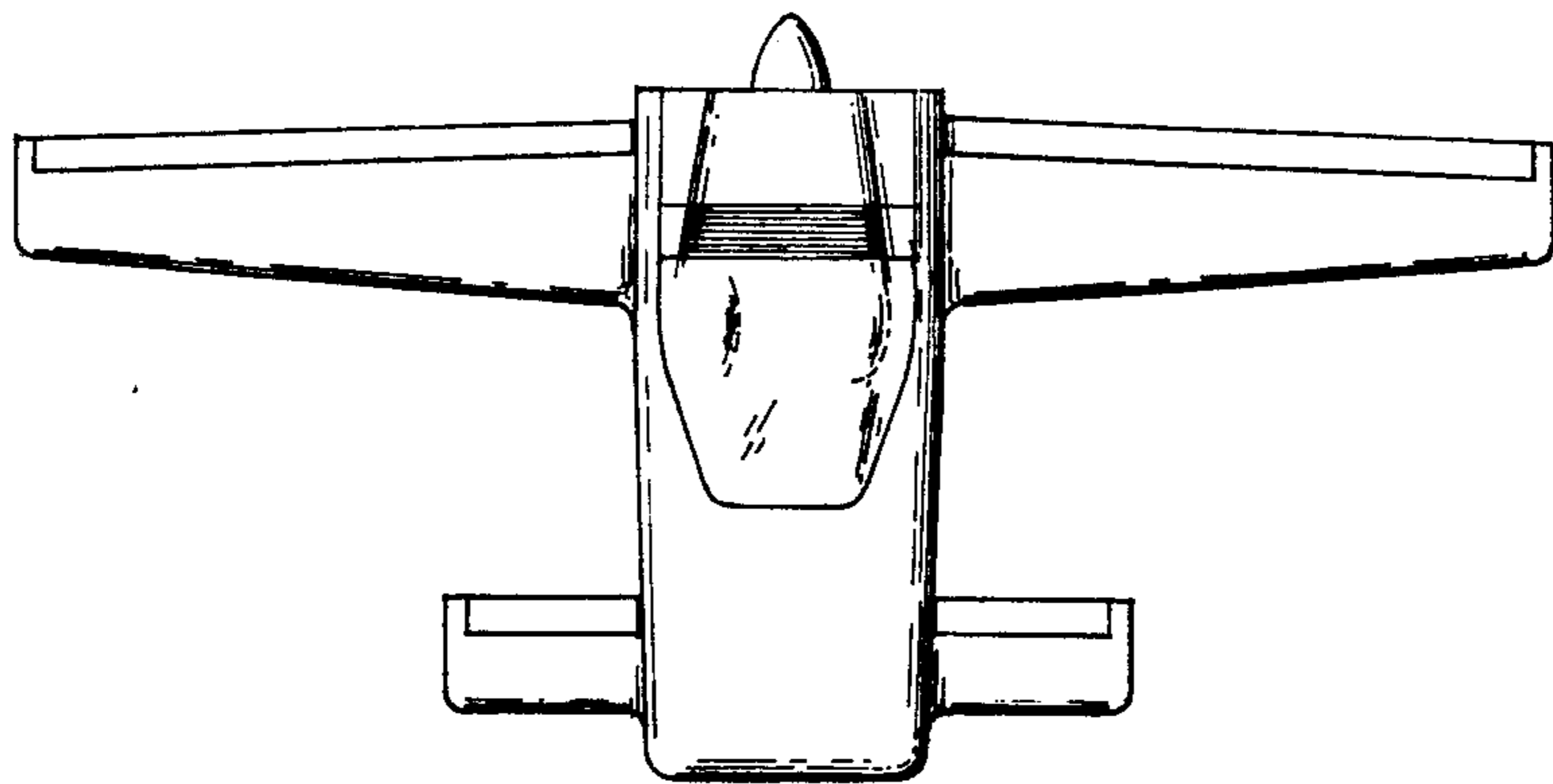

FIG. 1

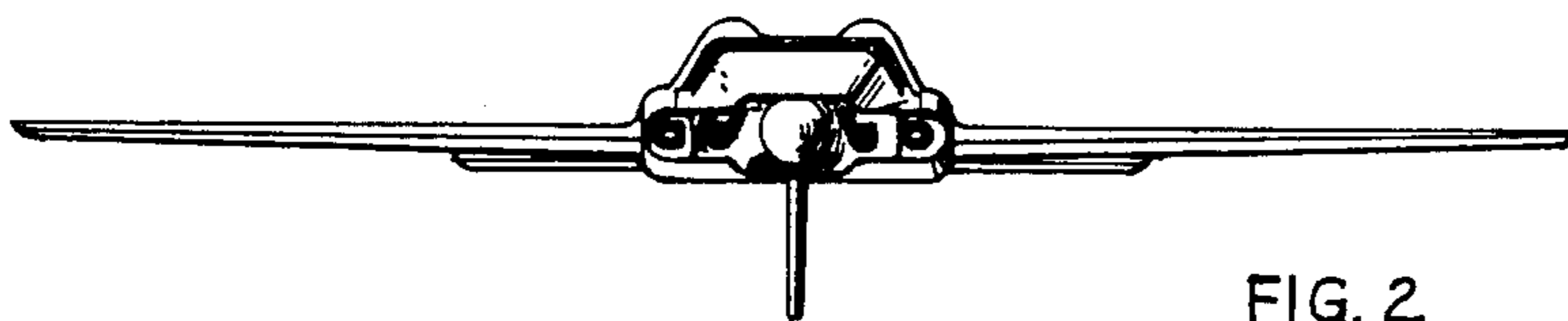

FIG. 2

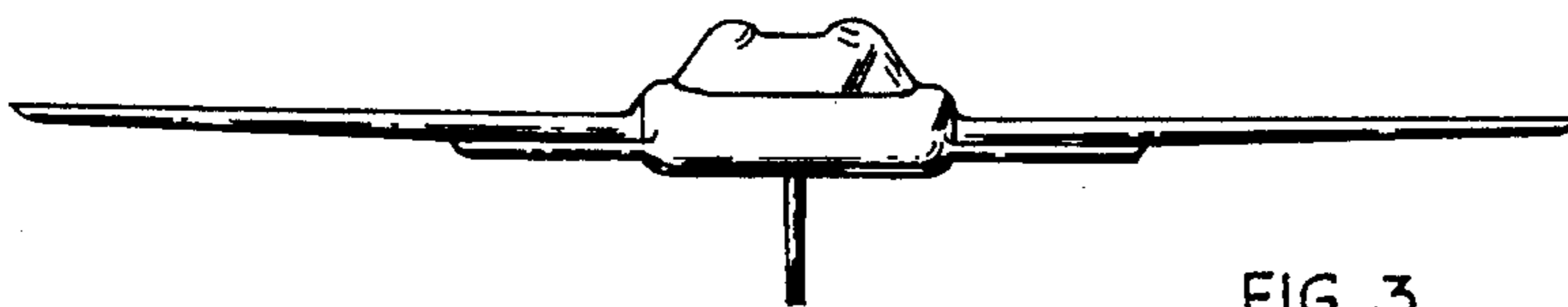

FIG. 3

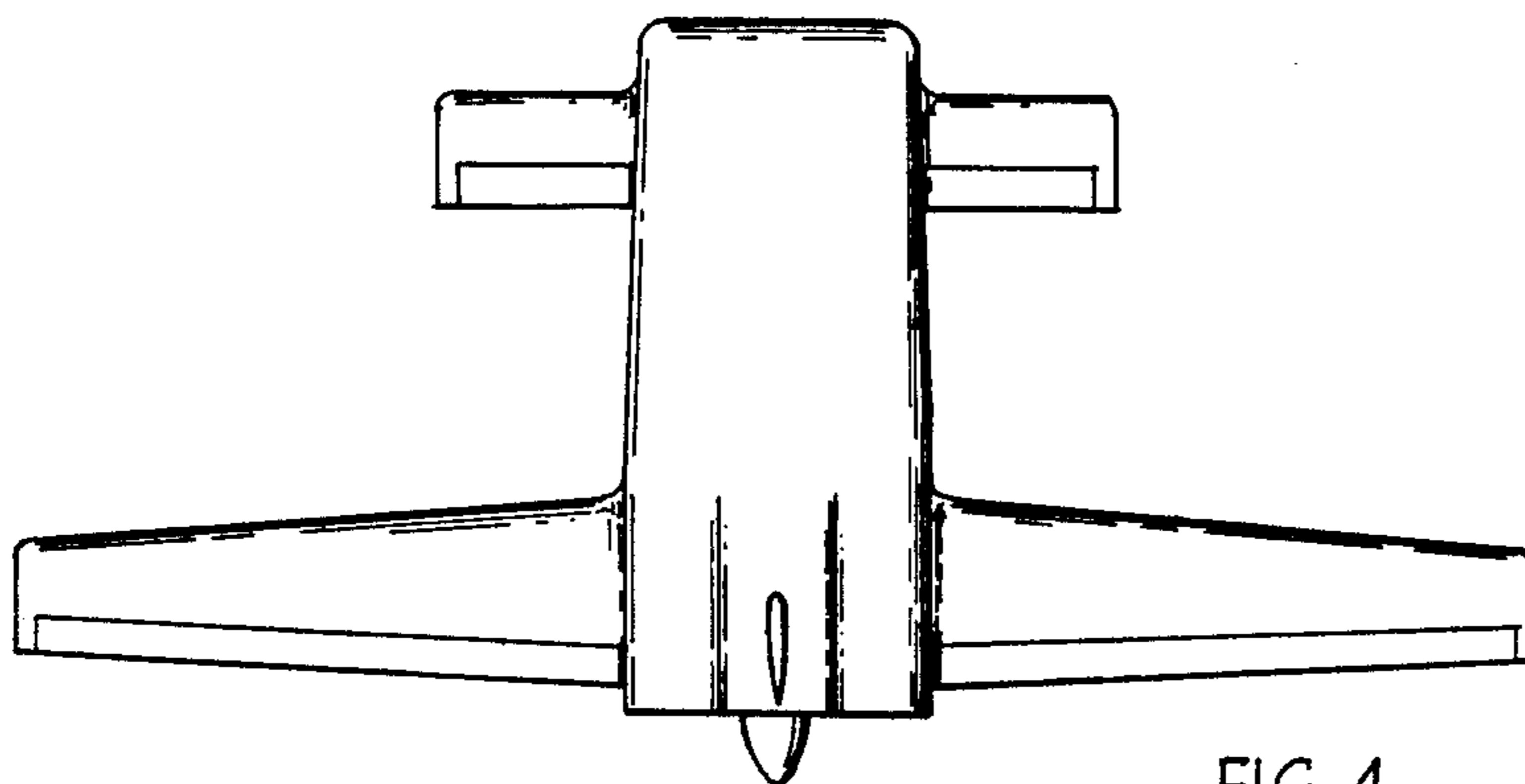

FIG. 4

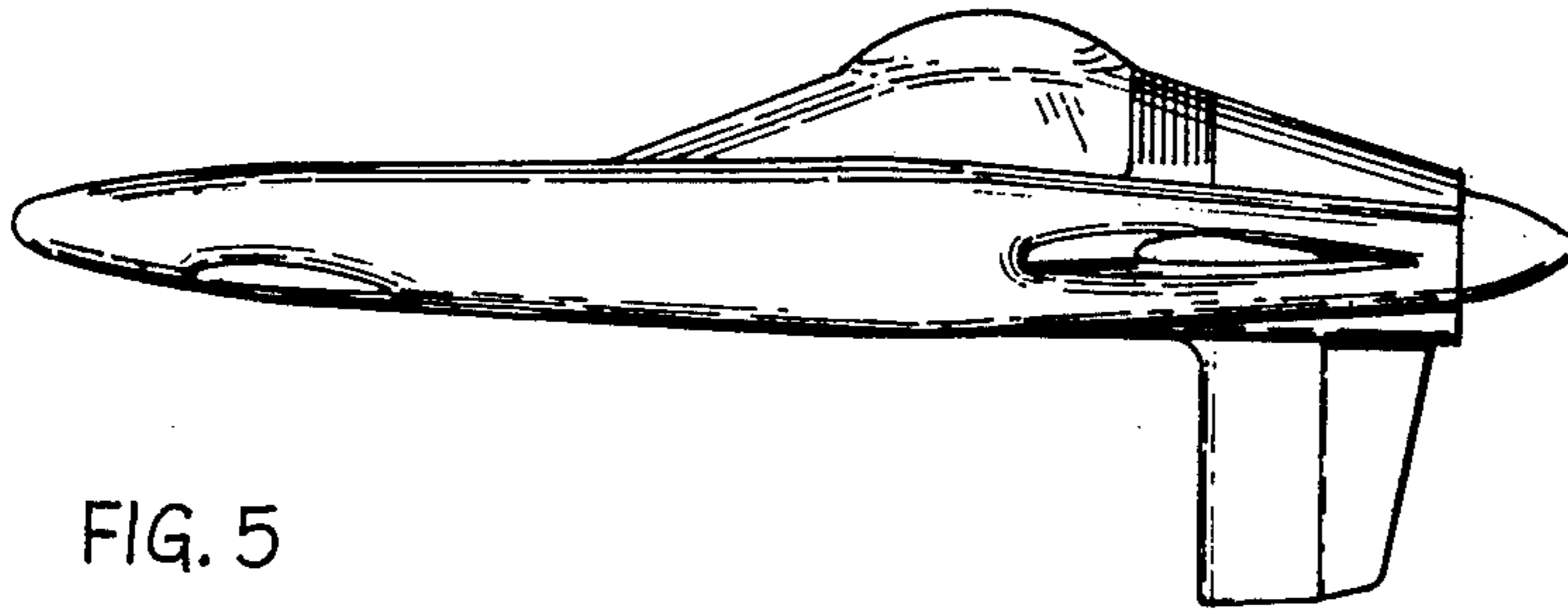

FIG. 5

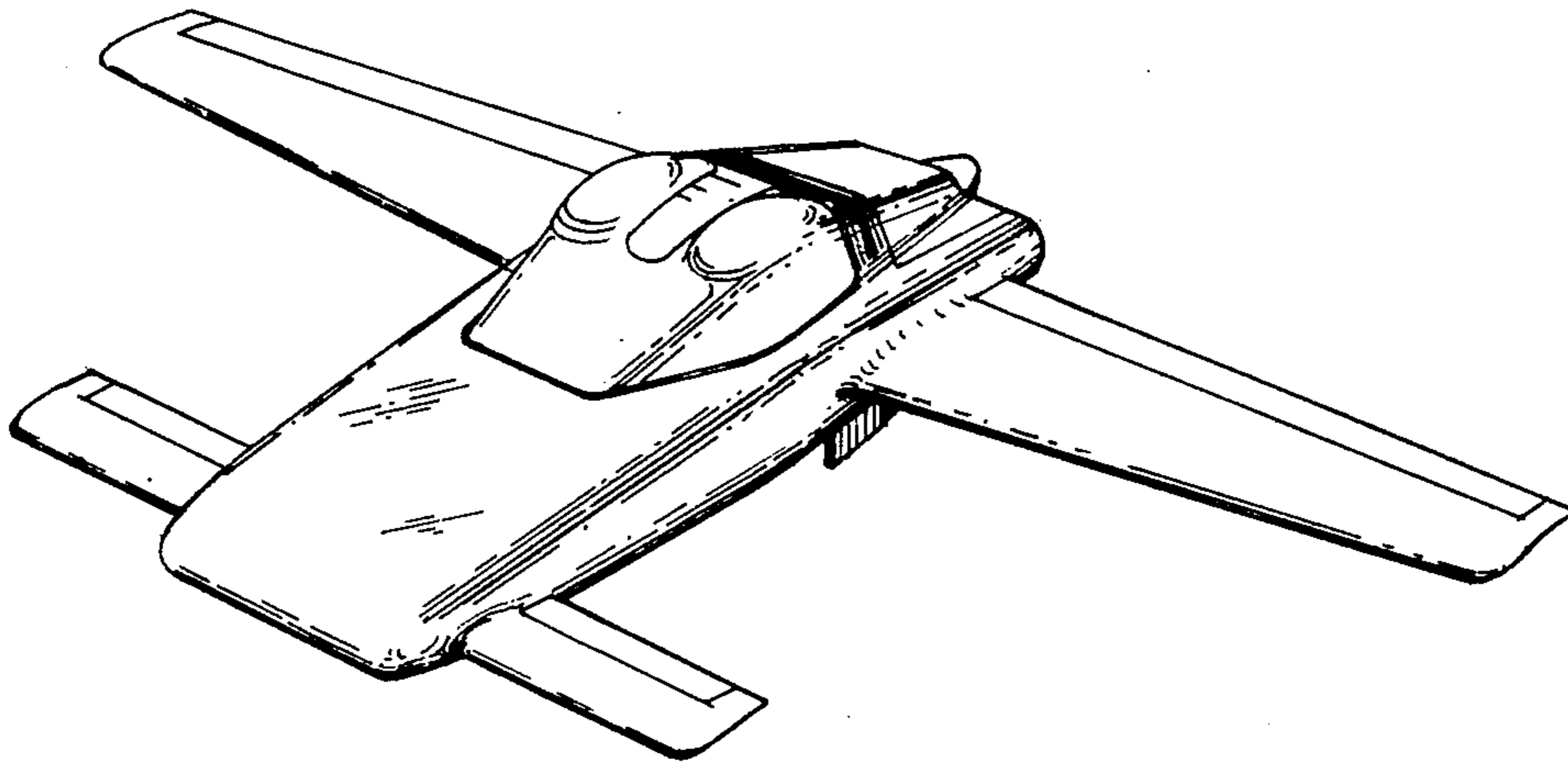

FIG. 6