

[54] COMBINED BRACKET AND LOCKING SUPPORT HOOK UNIT FOR HOLDING TRUCK TIRE CHAINS WHILE NOT IN USE

3,354,521 11/1967 Plett 24/230.5 R
4,050,496 9/1977 Weidler 24/241 P

[76] Inventor: Donald G. Gipson, 221 Manzanita Ave., Red Bluff, Calif. 96080

FOREIGN PATENT DOCUMENTS

24306 of 1907 United Kingdom 248/227

[**] Term: 14 Years

Primary Examiner—James M. Gandy
Attorney, Agent, or Firm—Roger B. Webster

[21] Appl. No.: 3,714

[57] CLAIM

[22] Filed: Jan. 15, 1979

The ornamental design for a combined bracket and locking support hook unit for holding truck chains while not in use, as shown and described.

[51] Int. Cl. D8—07; D8—08

[52] U.S. Cl. D8/333; D8/336; D8/367

[58] Field of Search D8/367, 371, 333, 336; 24/116 R, 230.5 R, 241 R, 241 P; 248/215, 304, 339, 73, 220.2, 224.3, 225.2, 225.1, 227, 224.4, 223.1, 314; 70/57, 58, 18, 19; 224/42.45 R, 42.46 R

DESCRIPTION

FIG. 1 is a top plan view of a combined bracket and locking support hook unit for holding truck chains while not in use showing my new design;

FIG. 2 is a side elevational view thereof with the anti-theft bar in open condition;

FIG. 3 is a front elevational view thereof;

FIG. 4 is a rear elevational view thereof; and

FIG. 5 is a bottom plan view thereof.

The broken line showing of the padlocks in the drawing are understood to be for illustrative purposes only.

[56] References Cited

U.S. PATENT DOCUMENTS

3,215,387 11/1965 Thompson et al. 248/224.3

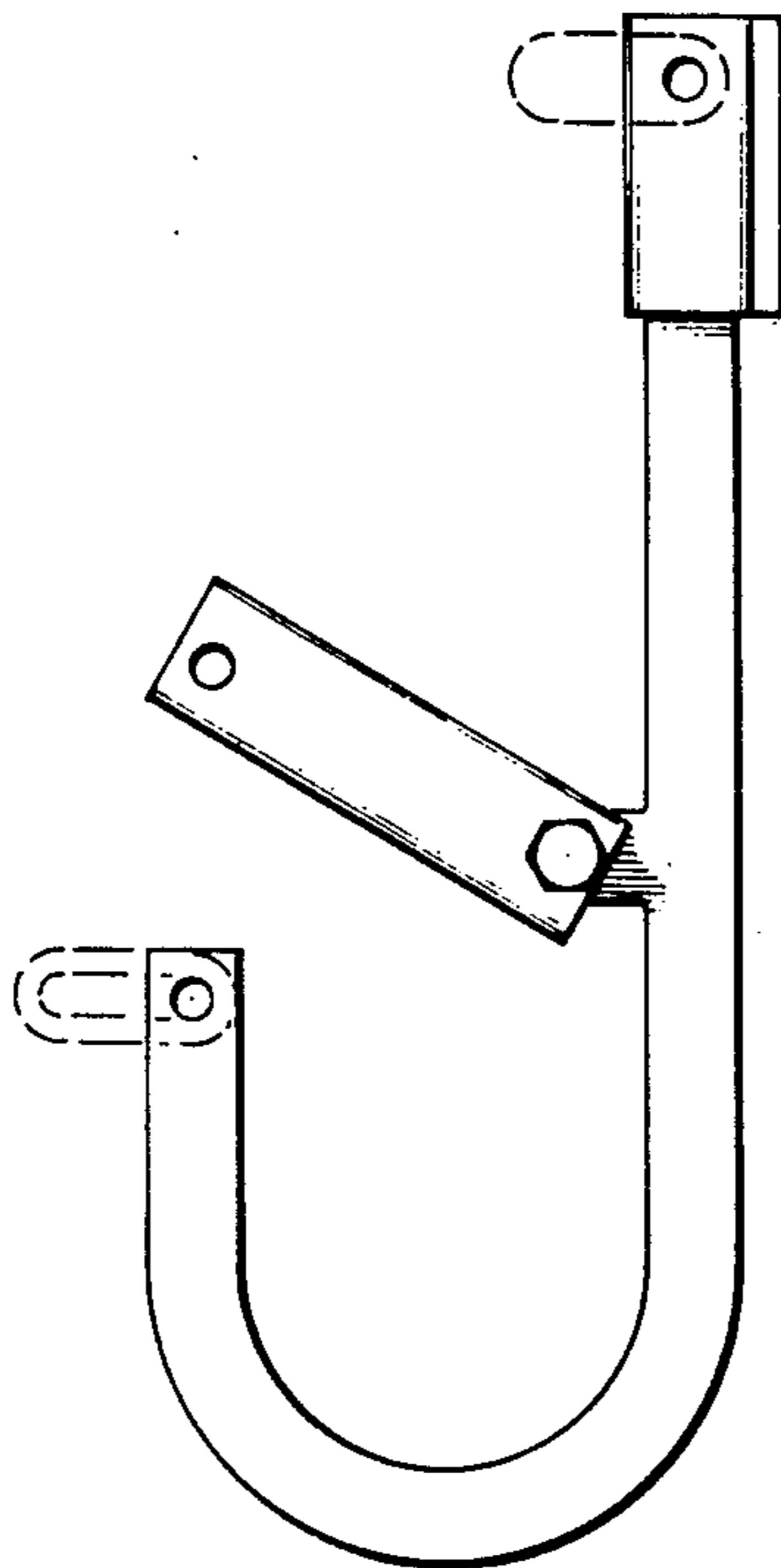

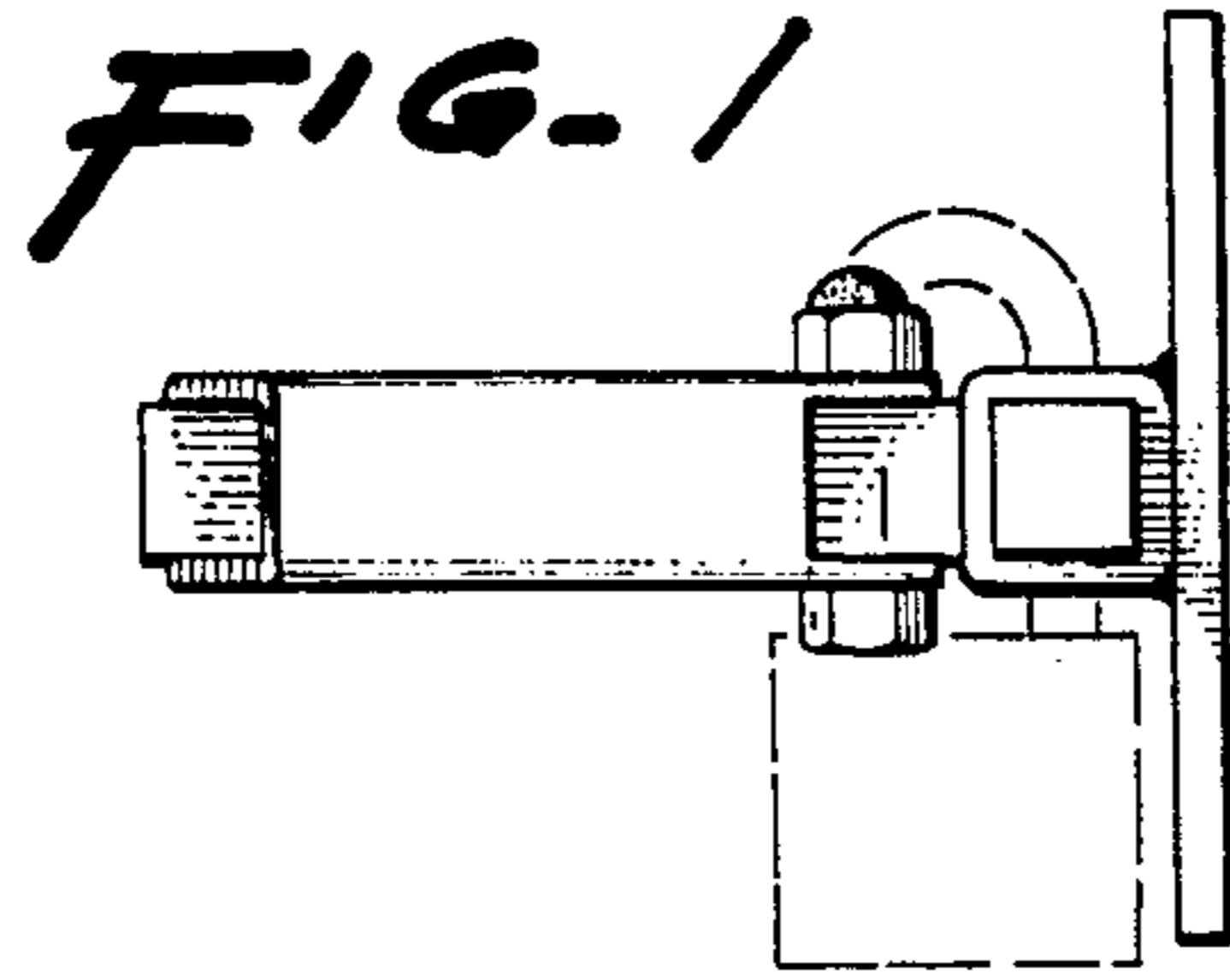

FIG. 2

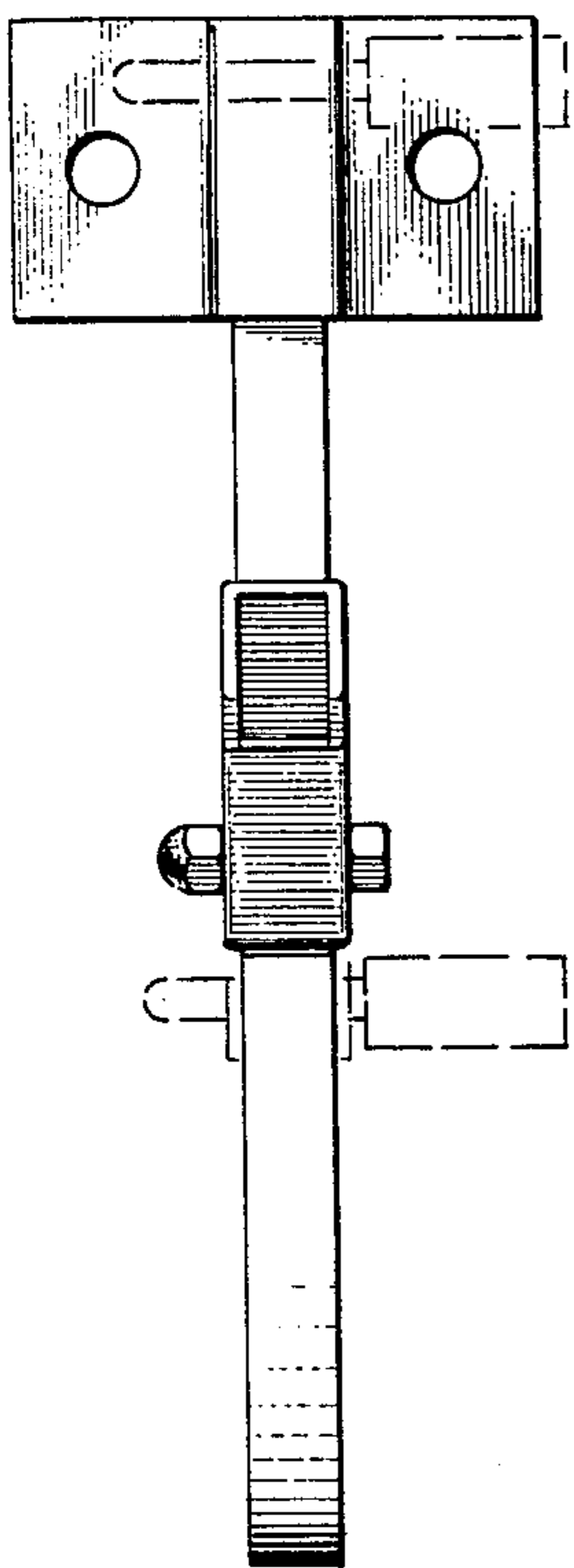

FIG. 3

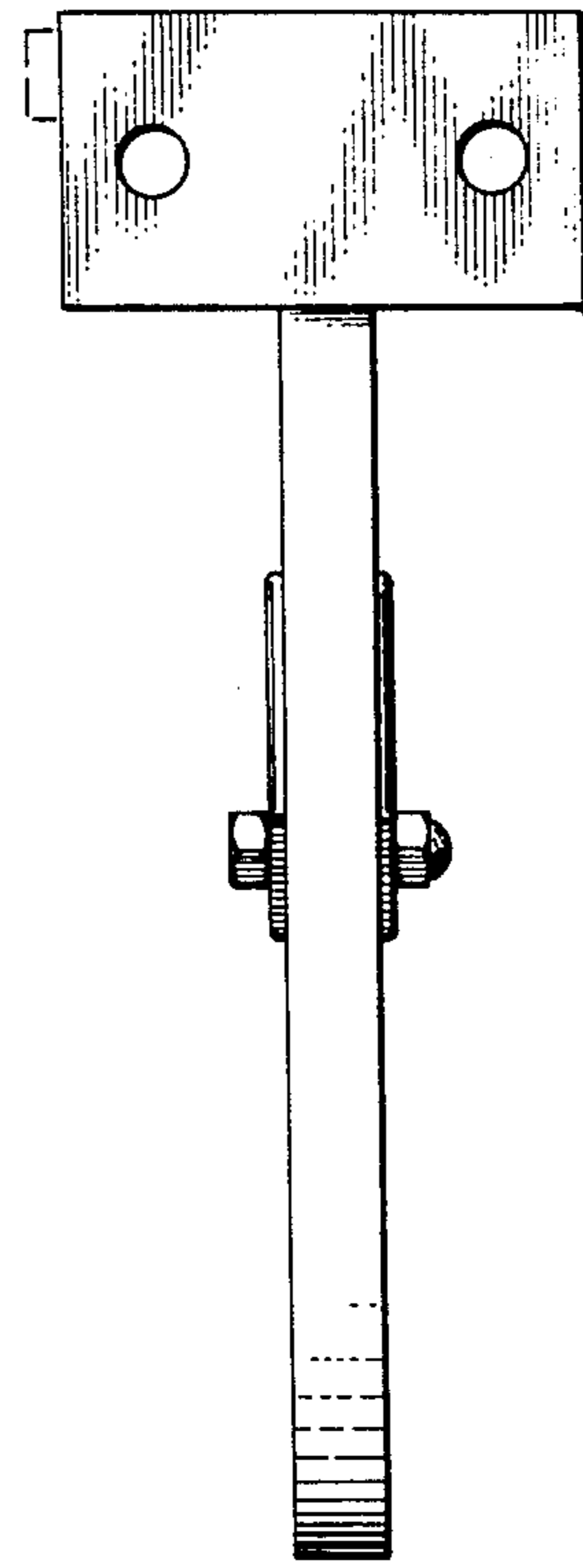
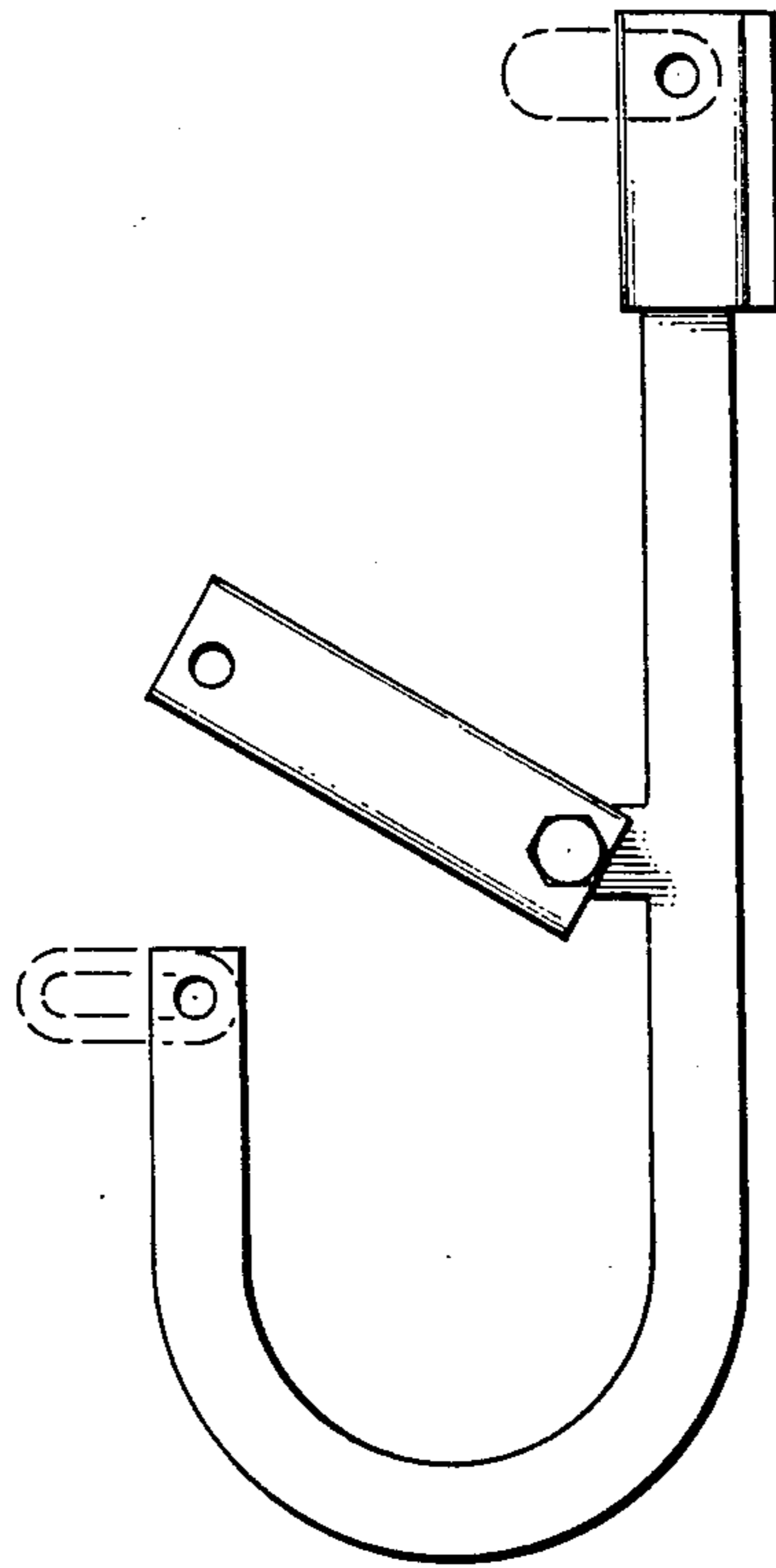

FIG. 4

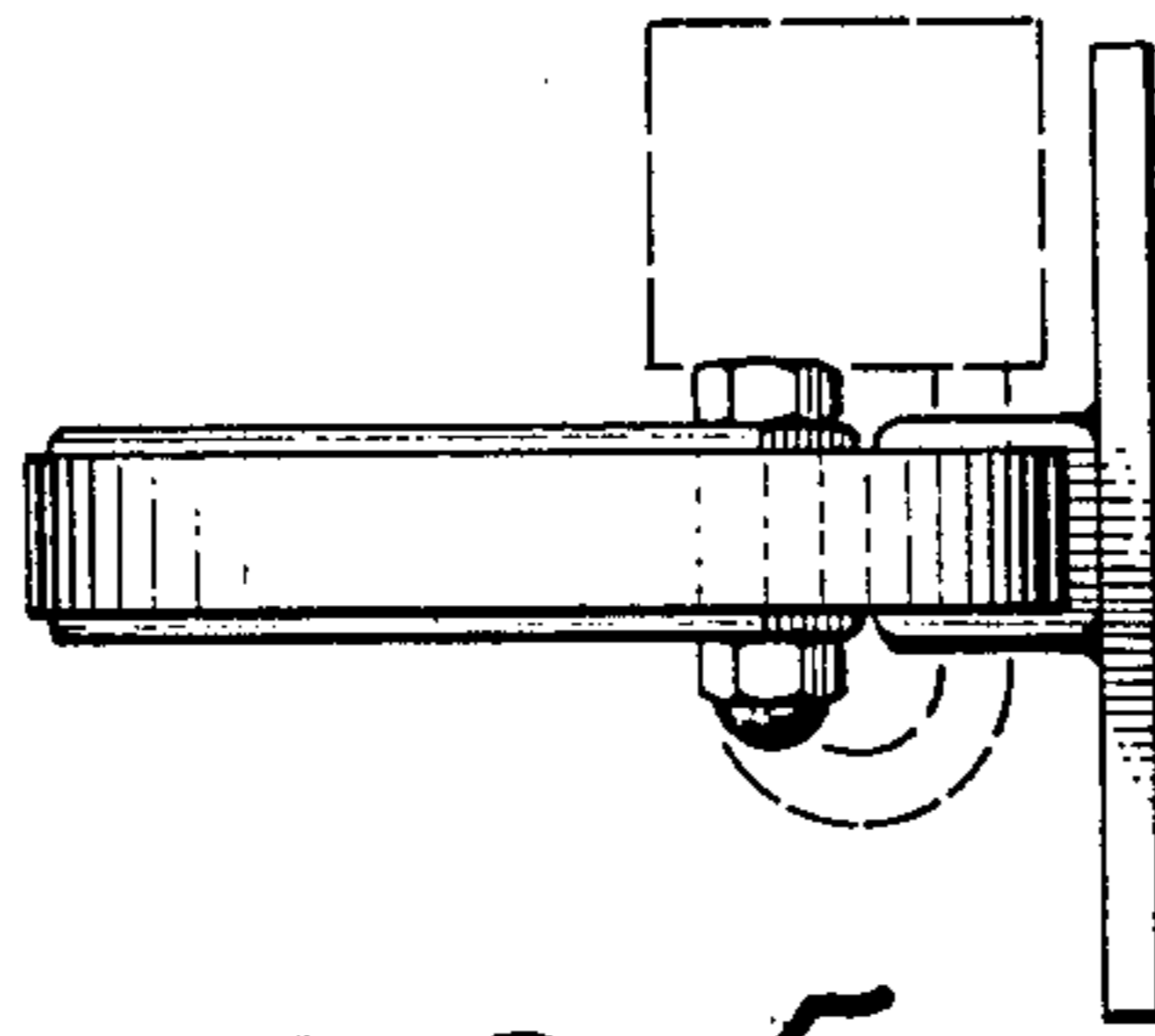

FIG. 5