

[54] COMPOST RETAINER

3,081,897 3/1963 Livingston 220/4 F

[76] Inventor: Ray A. Nattrass, 61 Clapham Rd., Sefton, New South Wales, Australia, 2162

FOREIGN PATENT DOCUMENTS

41303 6/1969 Finland 52/20

[**] Term: 14 Years

Primary Examiner—Peter Feldman
Attorney, Agent, or Firm—Leonard J. Robbins

[21] Appl. No.: 915,836

[57] CLAIM

[22] Filed: Jun. 15, 1978

The ornamental design for a compost retainer, as shown and described.

[30] Foreign Application Priority Data

DESCRIPTION

Dec. 20, 1977 [AU] Australia 73619
Apr. 12, 1978 [AU] Australia 74456

[51] Int. Cl. D7-07

FIG. 1 is a perspective view of a compost retainer wherein my design is embodied in a compost retainer having apertures formed in its sides, with the lids shown separated;

[52] U.S. Cl. D7/194; 220/1 T; 220/4 E

FIG. 2 is a top view thereof, without the lids;

[58] Field of Search D7/163, 189-195; D25/36; D11/156; 220/1 T, 4 R, 4 B, 4 E, 4 F, 72, 345, 80; 47/66, 68; D30/13-18; 119/61; 422/184; 52/20, 254

FIG. 3 is a bottom view thereof, without the lids;

FIG. 4 is a front elevational view thereof showing the lids raised above the retainer;

[56] References Cited

U.S. PATENT DOCUMENTS

531,184 12/1894 Harry 119/61
1,011,209 12/1911 Killion 220/4 F
1,293,549 2/1919 Reid 220/4.5
1,527,897 2/1925 Mittinger 220/72 X
2,495,132 1/1950 Remco 220/76 X
2,594,012 4/1952 Griffin 220/72

FIG. 5 is a rear elevational view thereof with the lids omitted;

FIG. 6 is a right side elevational view of FIG. 4 with one of the lids raised;

FIG. 7 is a left side elevational view of FIG. 4 with one of the lids raised; and

FIG. 8 is a perspective view of a compost retainer wherein my design is embodied in a compost retainer similar to that in FIG. 1, but with the apertures omitted.

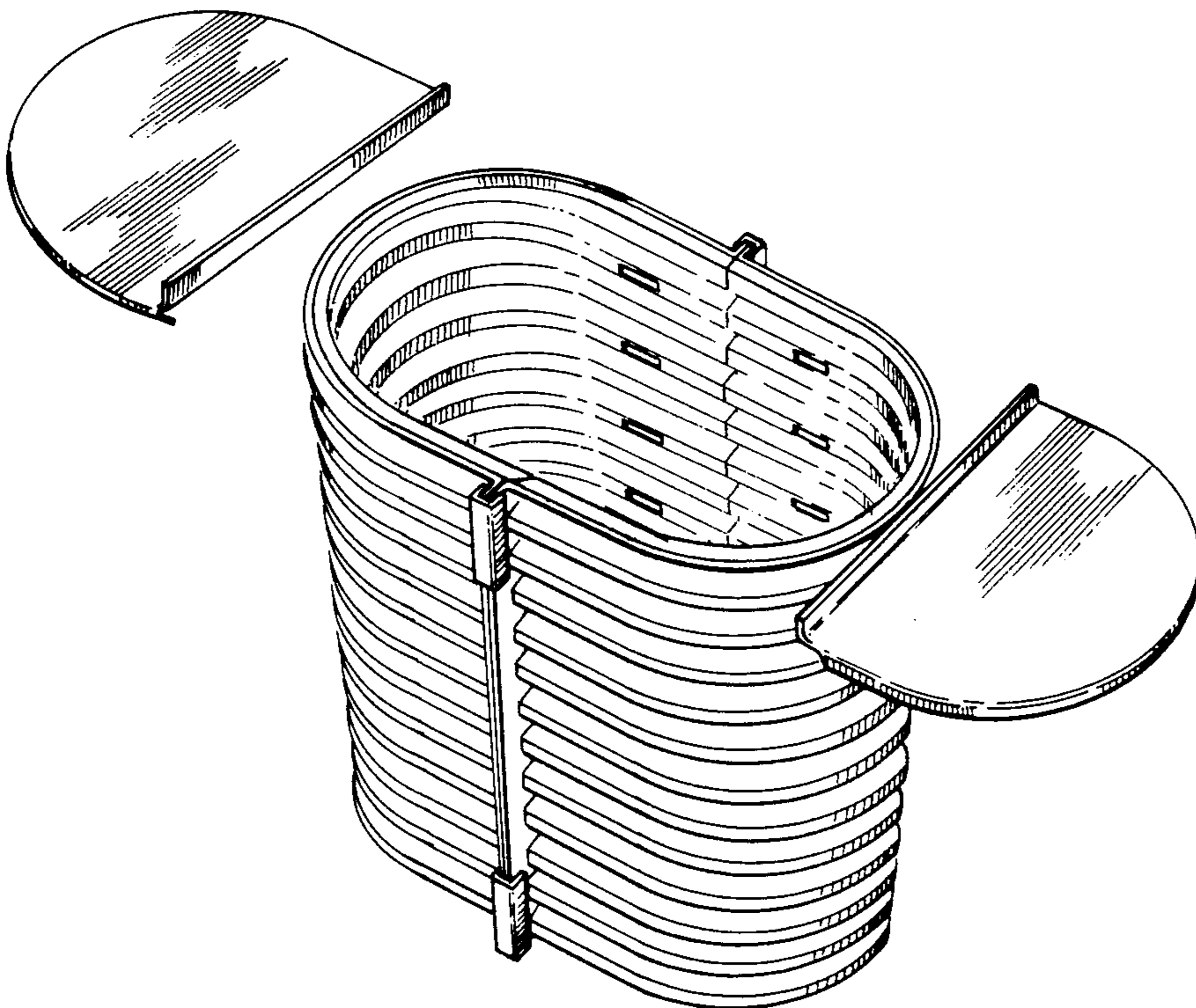

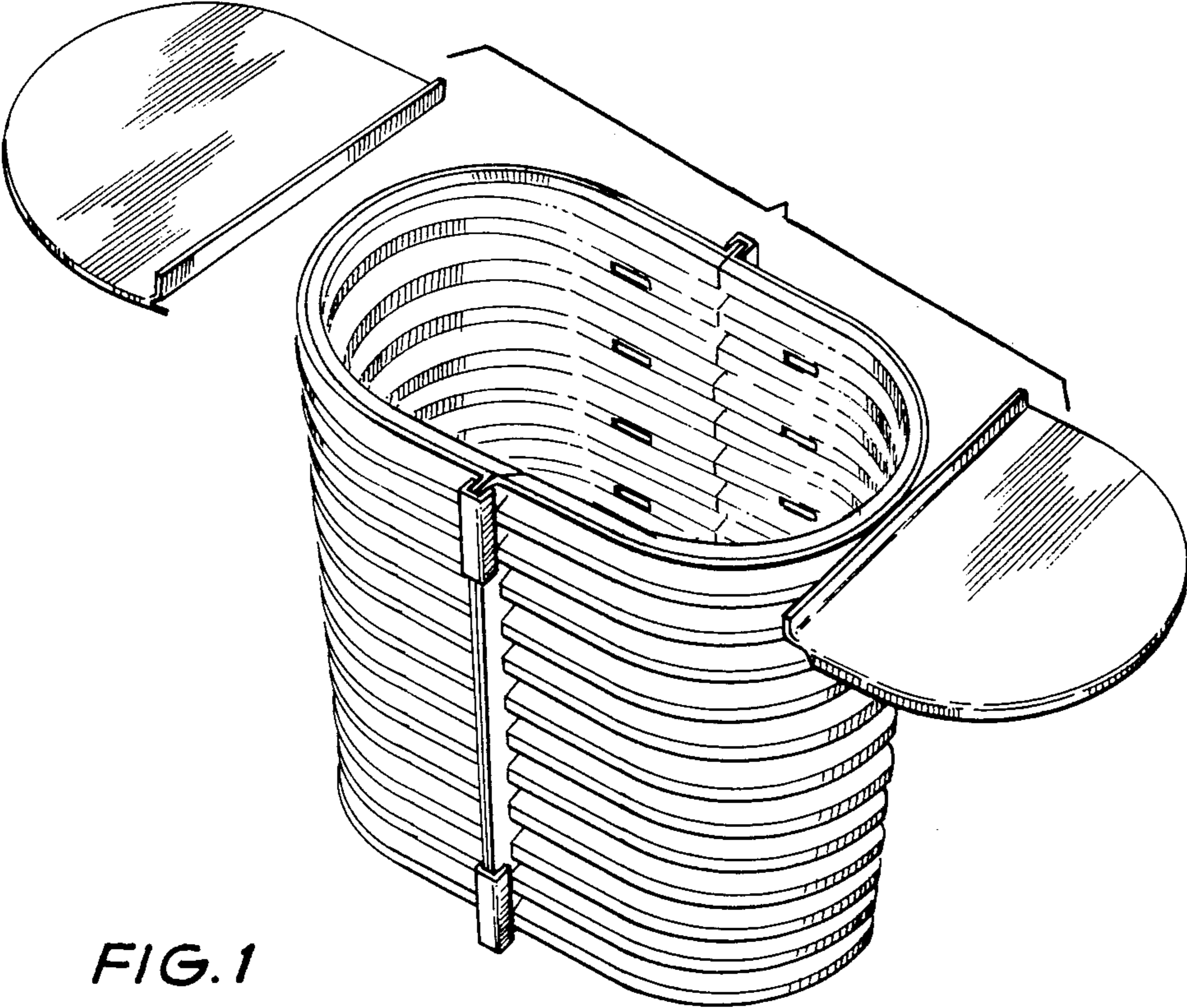

FIG. 1

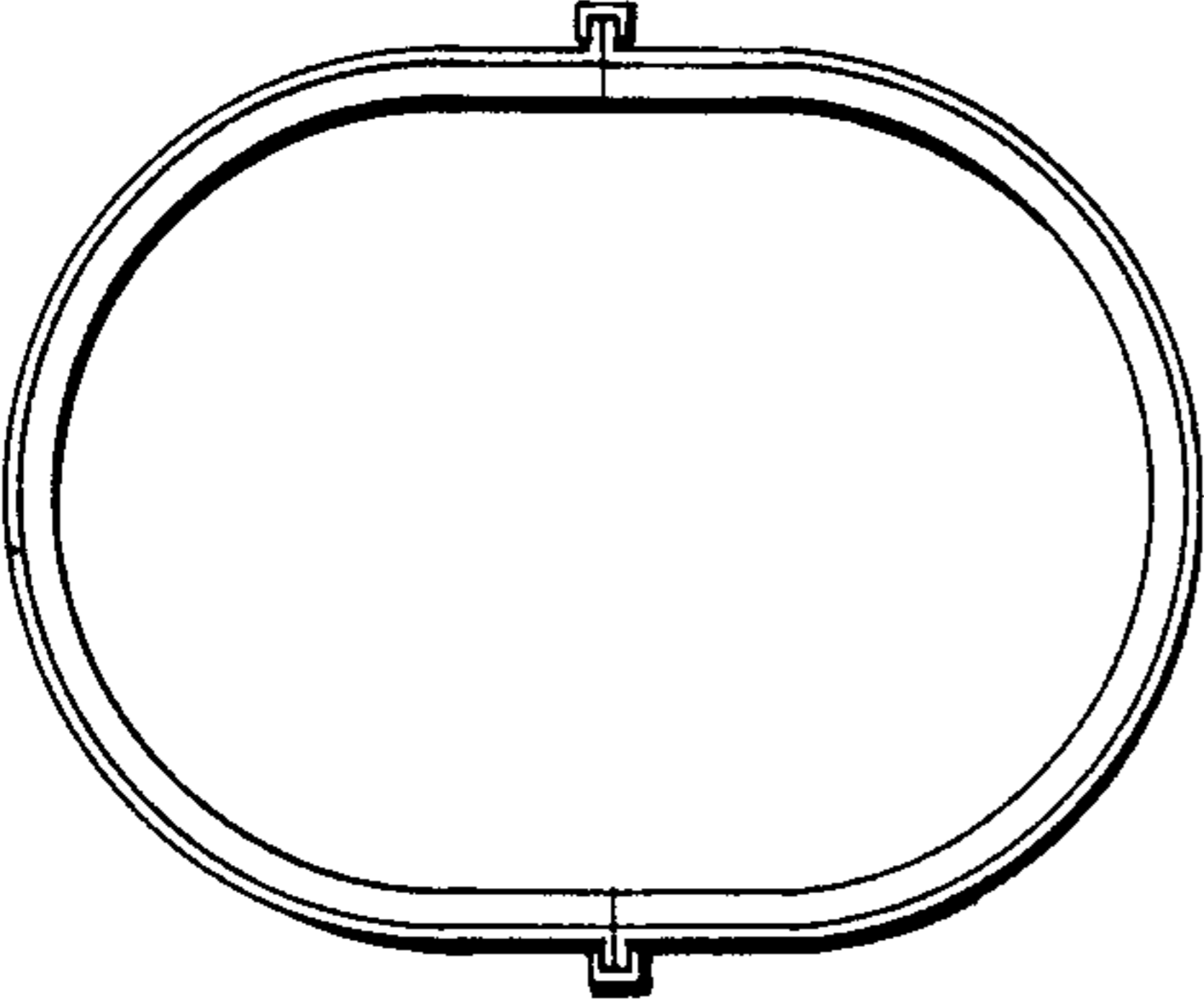

FIG. 2

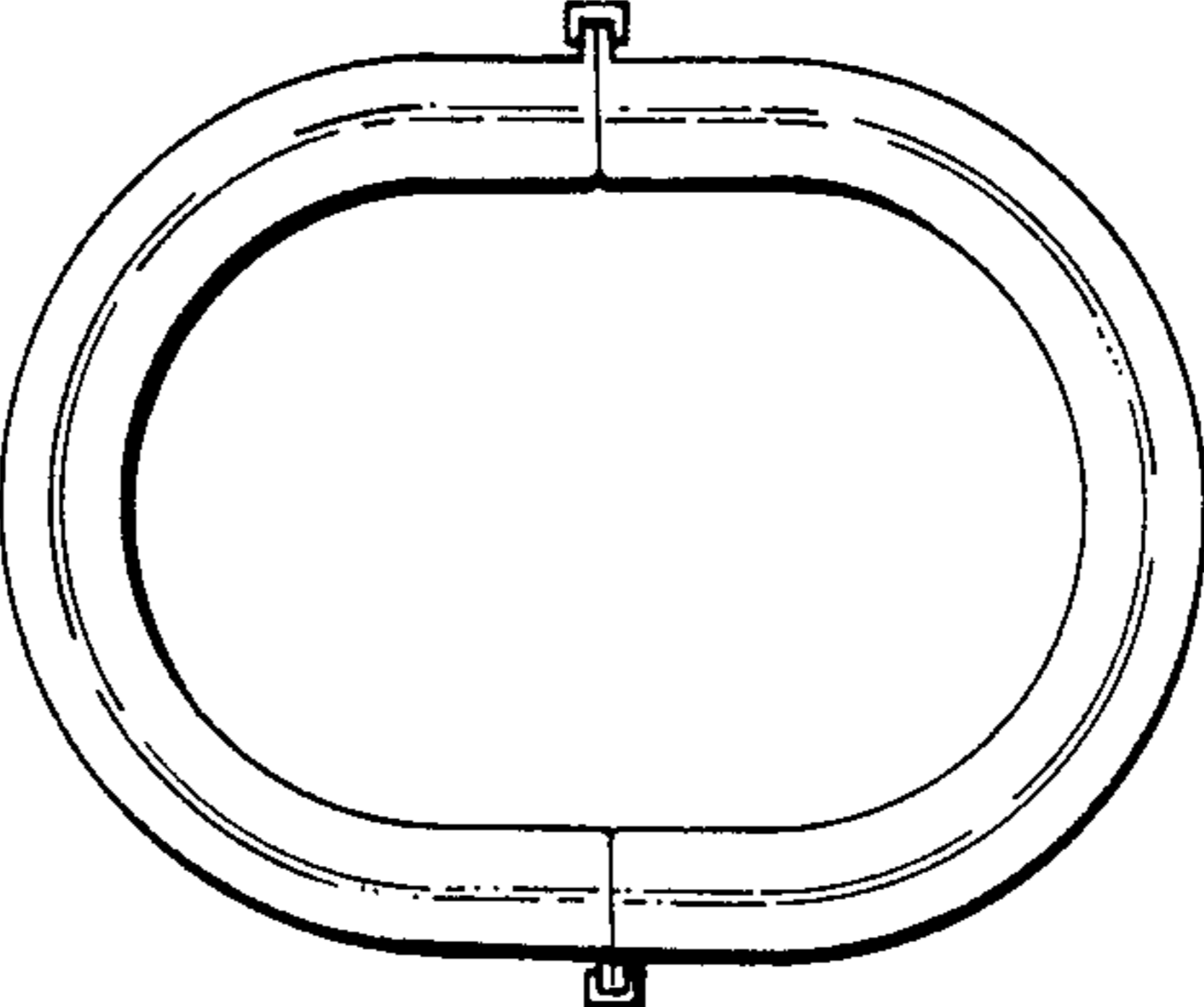

FIG. 3

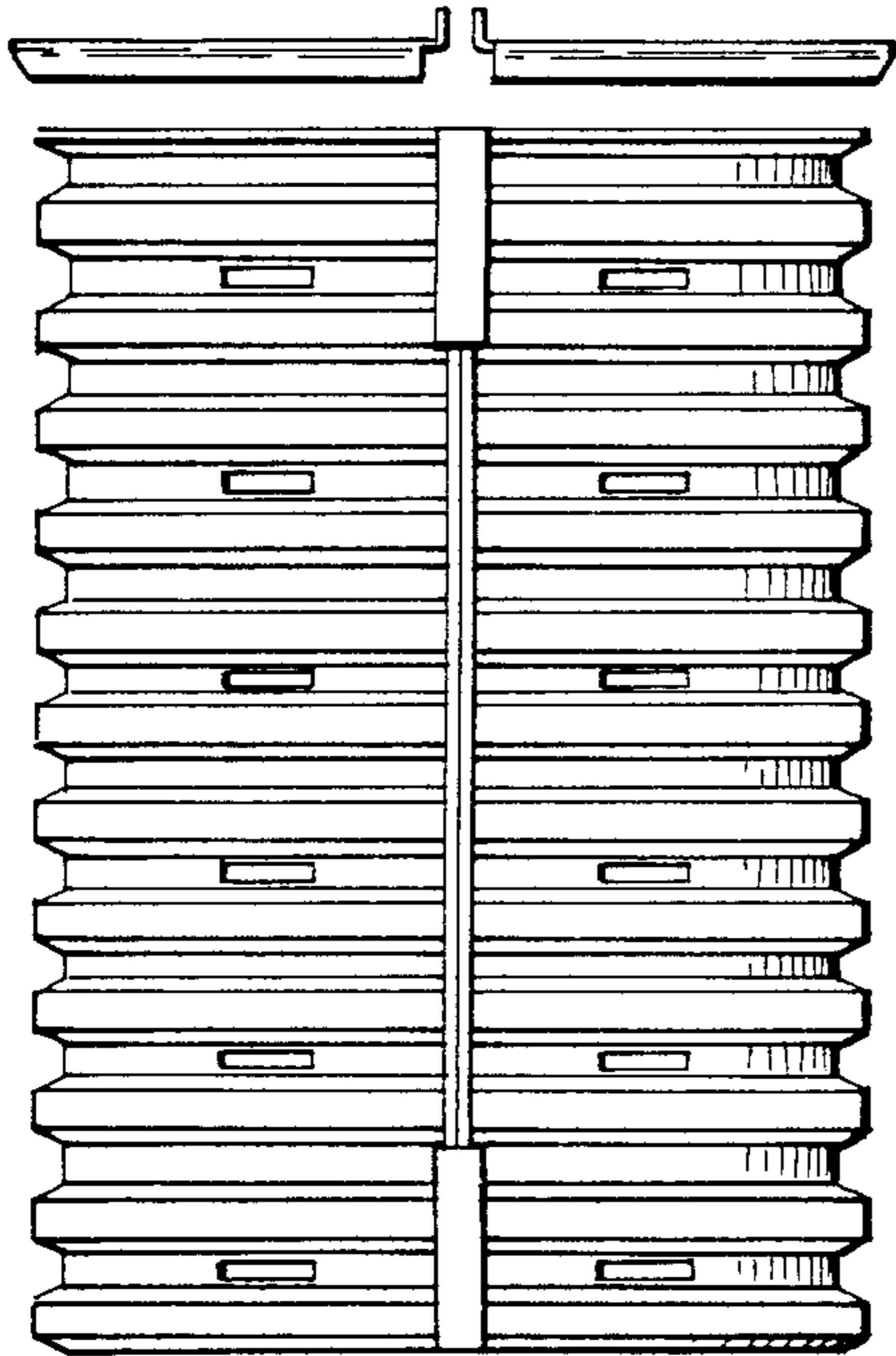

FIG. 4

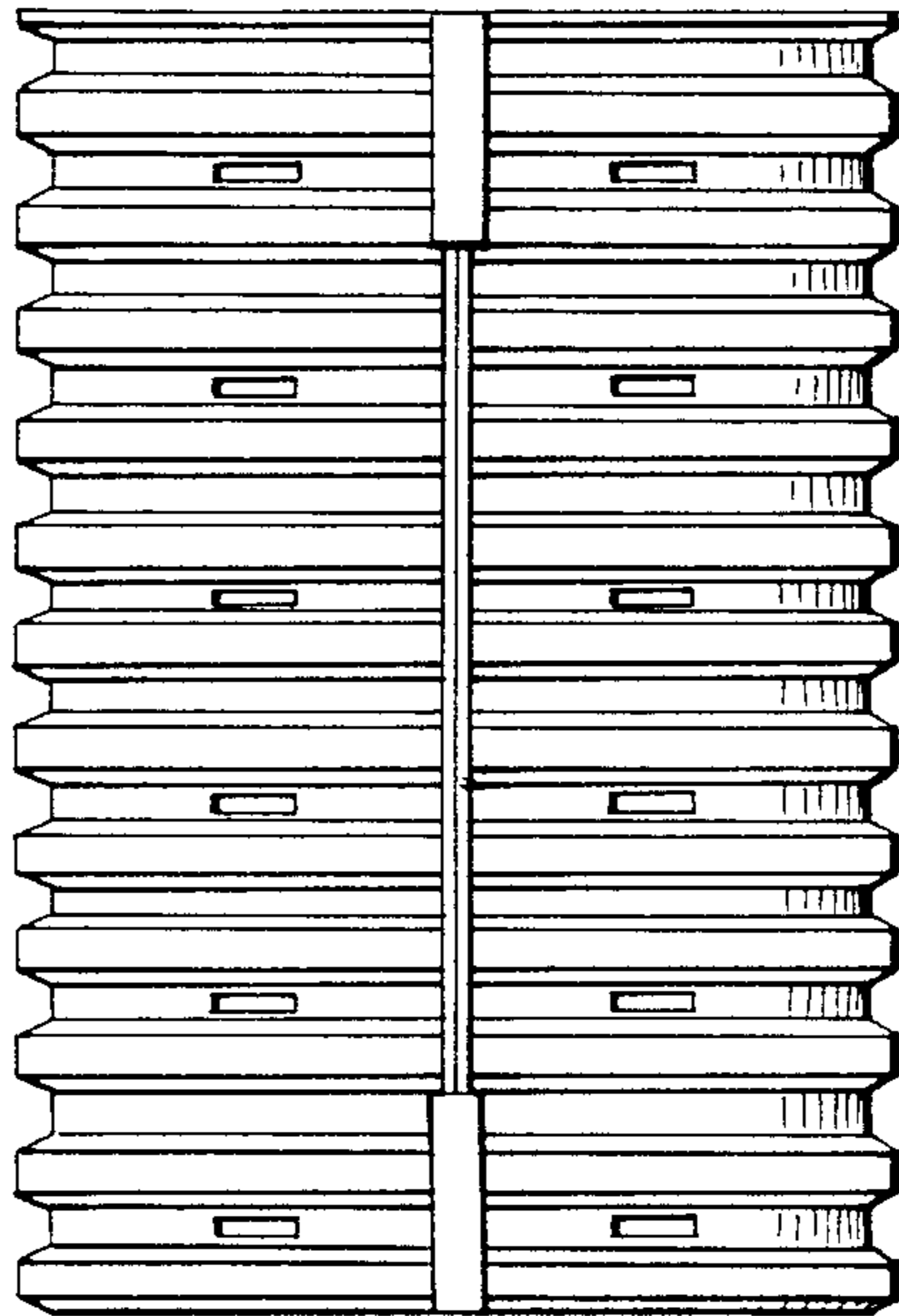

FIG. 5

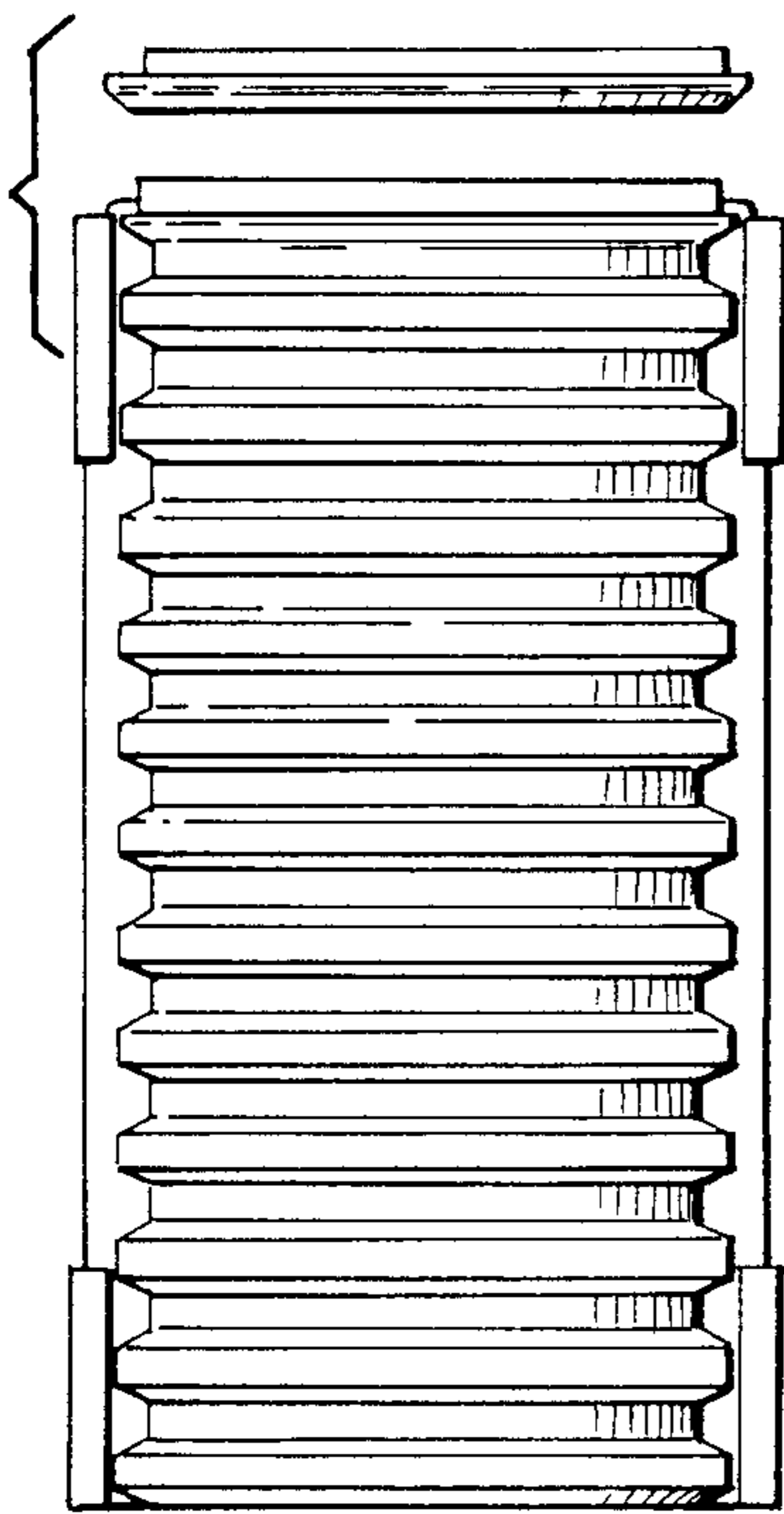

FIG. 6

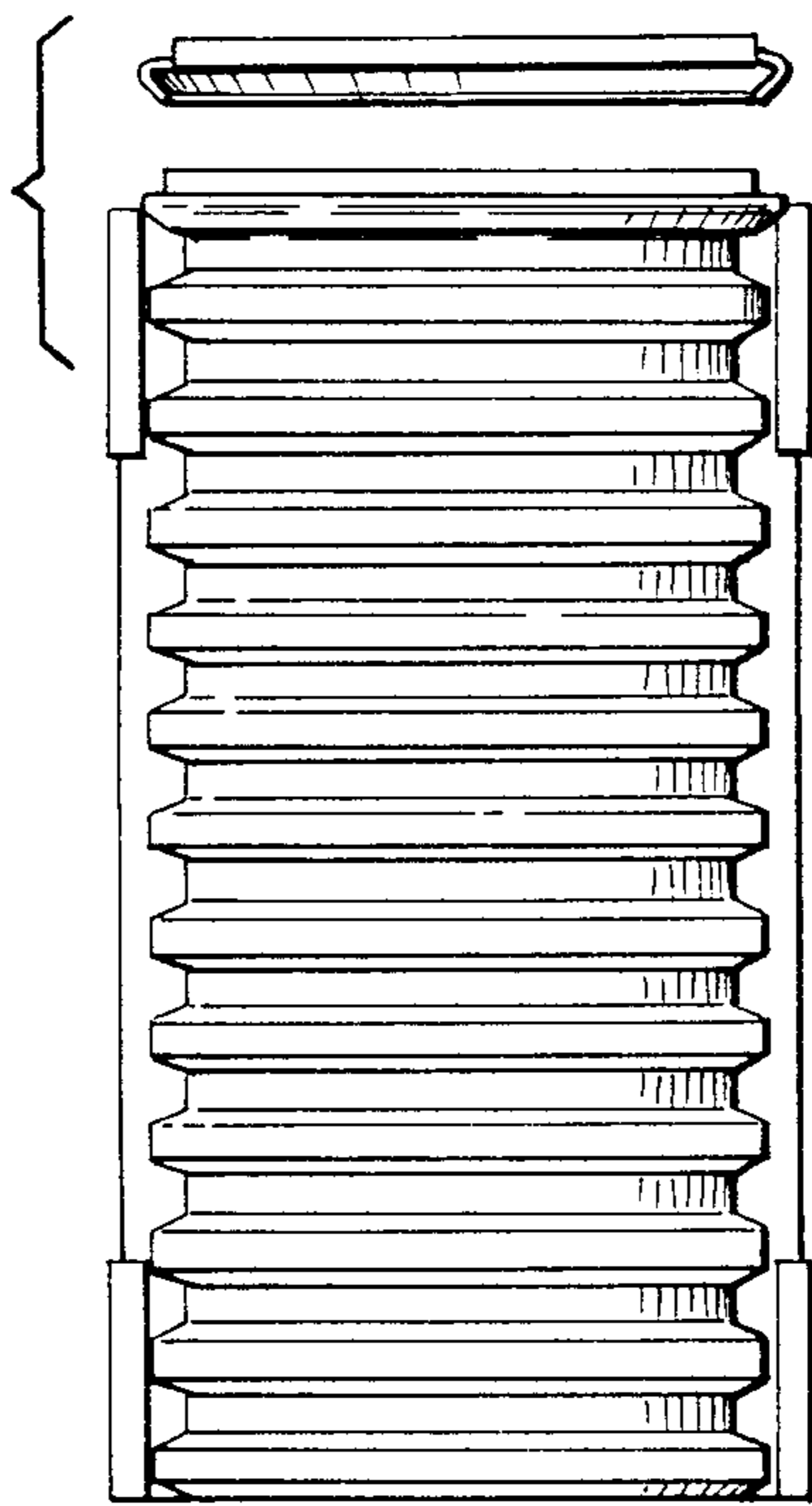

FIG. 7

