

[54] TRUCK CAB CLEARANCE LIGHT

[76] Inventor: Bill R. Alsman, 2200 Christmas Tree La., Riverbank, Calif. 95367

[**] Term: 14 Years

[21] Appl. No.: 84,115

[22] Filed: Oct. 12, 1979

[51] Int. Cl. D26-06

[52] U.S. Cl. D26/28

[58] Field of Search D26/28, 29, 35, 36; 362/61, 307, 310, 311, 362, 367, 375

[56] References Cited

U.S. PATENT DOCUMENTS

- 2,855,502 10/1958 Johnson 362/61 X
- 3,229,081 1/1966 Kowonen et al. D26/35 X

FOREIGN PATENT DOCUMENTS

24900 3/1963 German Democratic Rep. 362/61

Primary Examiner—Susan J. Lucas
Attorney, Agent, or Firm—Harvey B. Jacobson

[57] CLAIM

The ornamental design for a truck cab clearance light, substantially as shown.

DESCRIPTION

FIG. 1 is a perspective view of a truck cab clearance light showing my new design;
FIG. 2 is a side elevational view thereof as seen from the left side thereof;
FIG. 3 is a bottom plan view thereof;
FIG. 4 is a front elevational view thereof; and
FIG. 5 is a rear elevational view thereof.

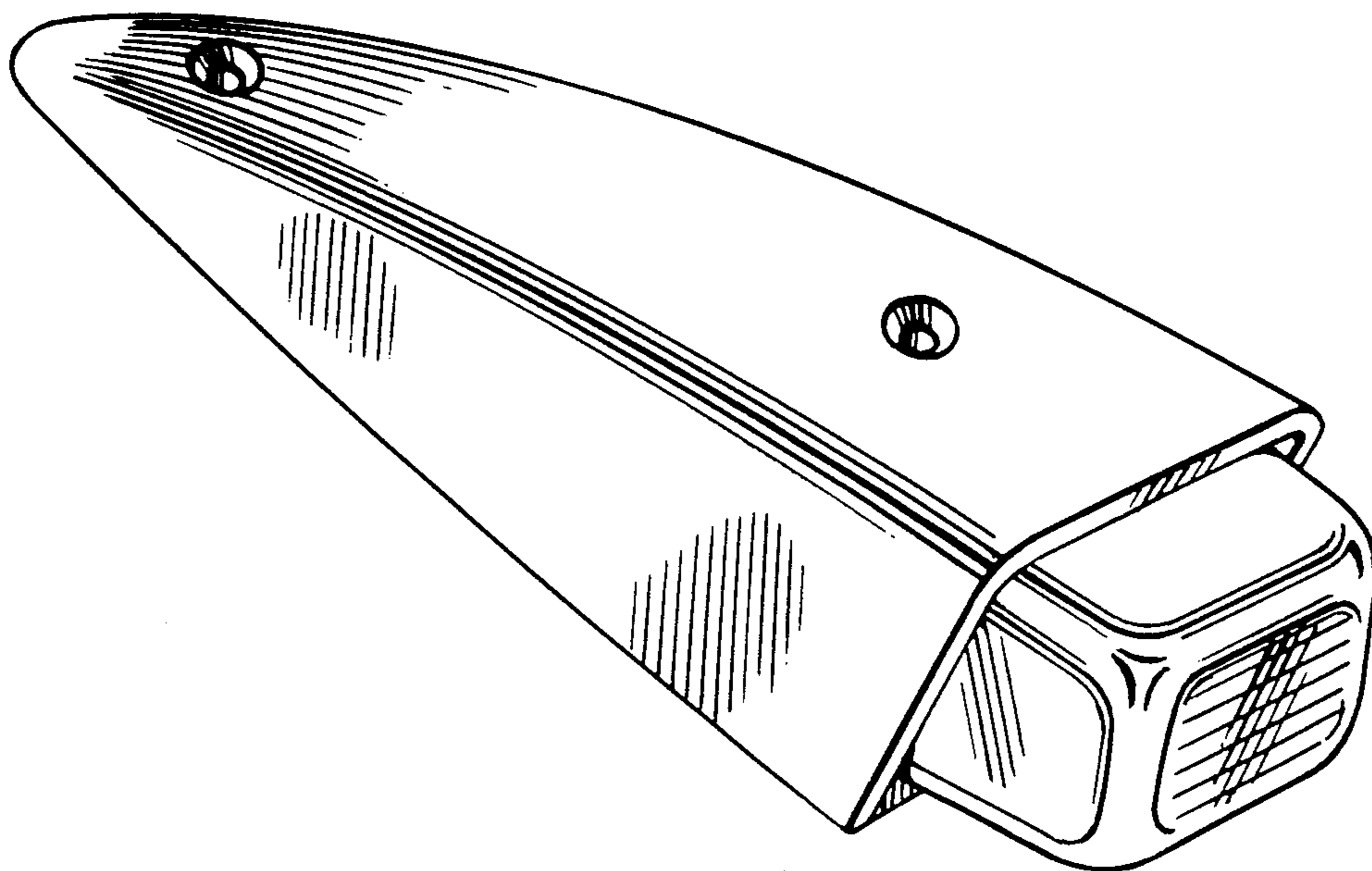

Fig. 1

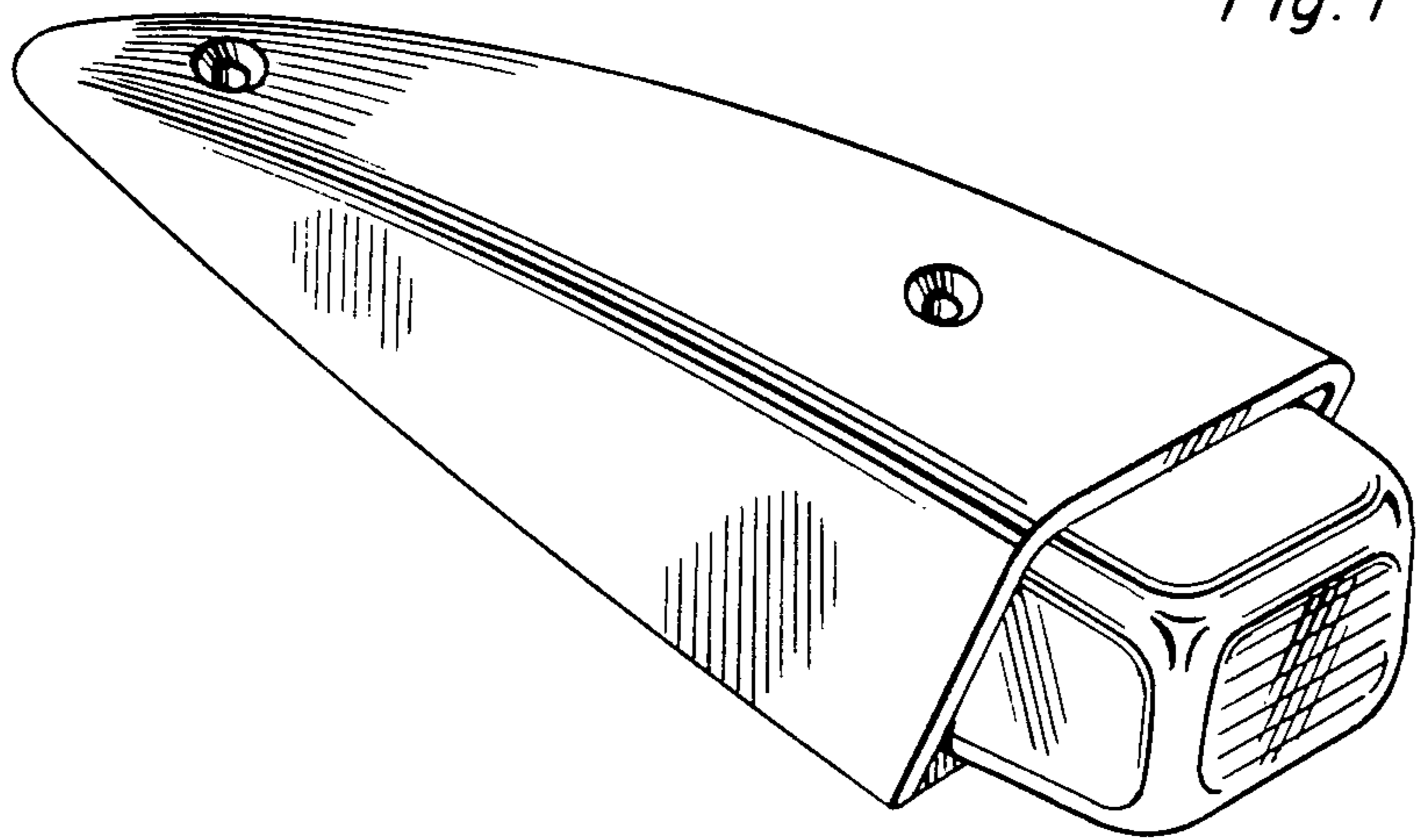

Fig. 2

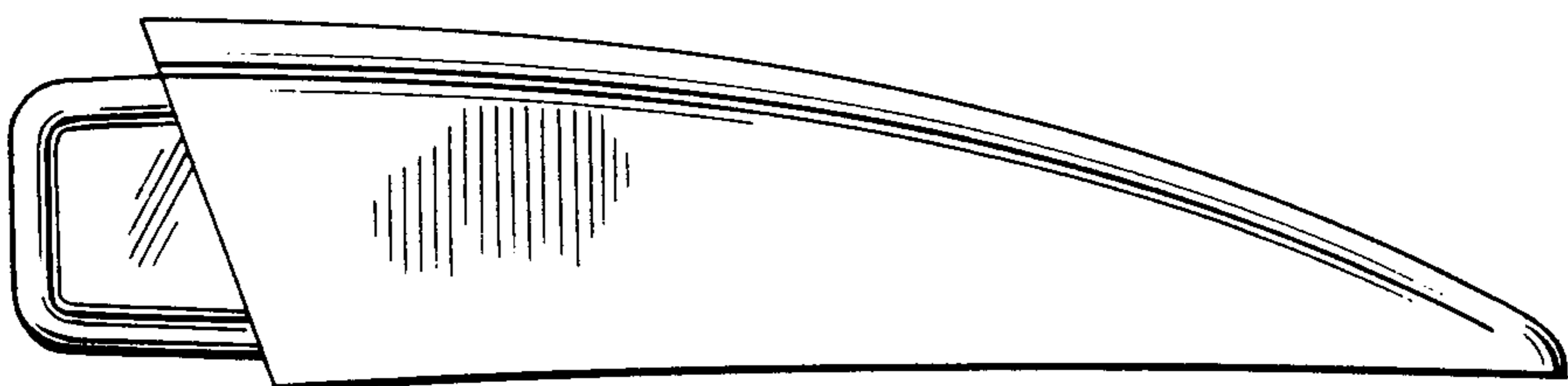

Fig. 3

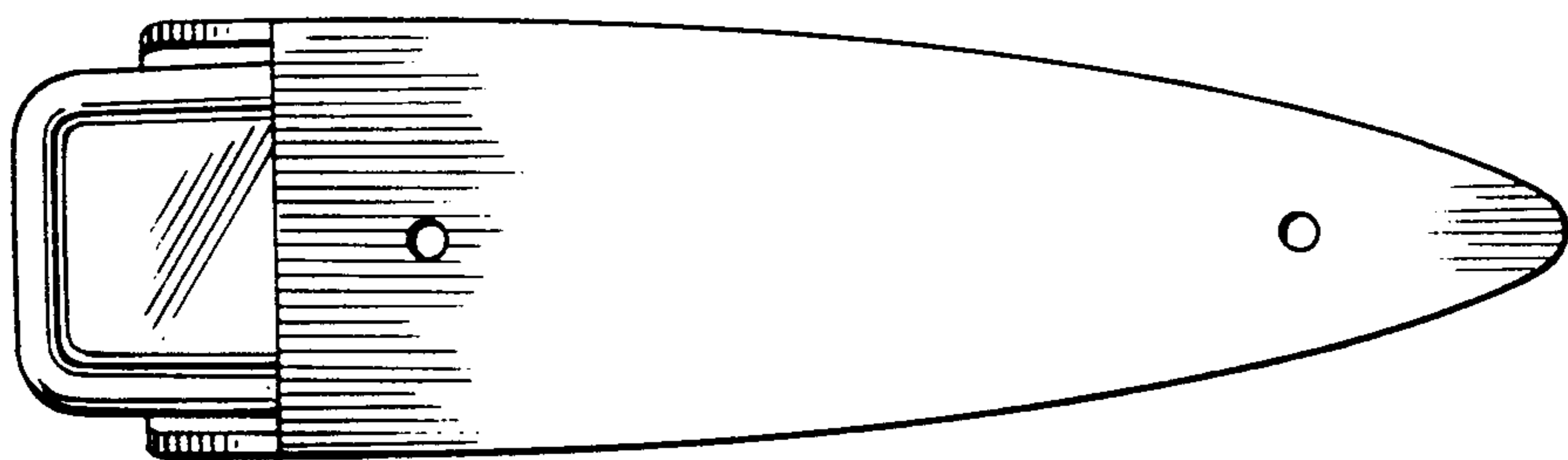

Fig. 4

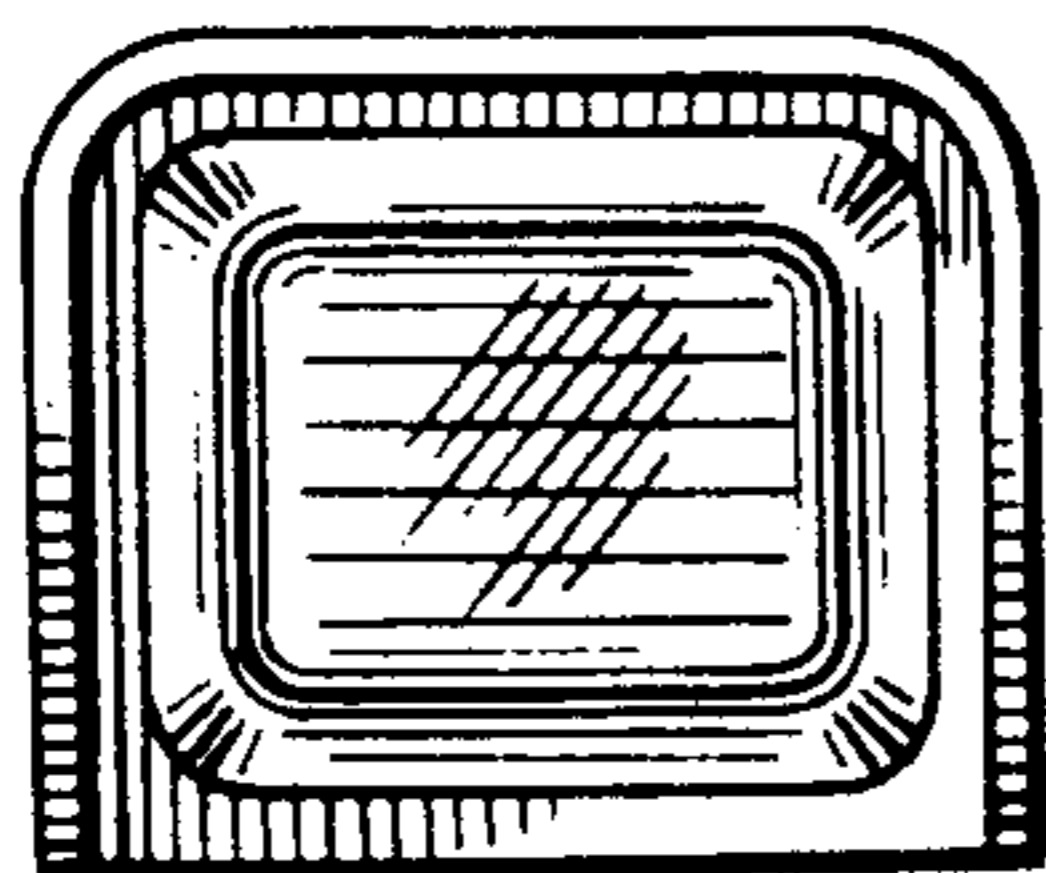

Fig. 5

